

MIDWAY CITY SANITARY DISTRICT

**BOARD OF DIRECTORS
REGULAR MEETING AGENDA
DISTRICT OFFICE
BOARD ROOM
14451 CEDARWOOD STREET
WESTMINSTER, CA 92683**

**Tuesday, May 21, 2024
5:30 P.M.**

OUR MISSION STATEMENT

THE BOARD OF DIRECTORS AND EMPLOYEES OF THE MIDWAY CITY SANITARY DISTRICT WORK DILIGENTLY TO PROVIDE SEWER AND SOLID WASTE SERVICES TO THE RESIDENTS OF THE DISTRICT. OUR TOP PRIORITY IS TO ACCOMPLISH THIS IN AN ETHICAL, EFFICIENT, AND COST-EFFECTIVE MANNER THAT WILL PROTECT THE HEALTH AND SAFETY OF THOSE WE SERVE.

In accordance with the requirements of California Government Code Section 54954.2, this Agenda is posted not less than 72 hours prior to the meeting date and time above. All written materials relating to each agenda item are available for public inspection in the office of the Board Secretary.

In the event any matter not listed on this agenda is proposed to be submitted to the Board for discussion and/or action, it will be done in compliance with Section 54954.2, or as set forth on a Supplemental Agenda posted not less than 72 hours prior to the meeting.

Please Note: The District complies with the provisions of the Americans with Disabilities Act (ADA). Anyone needing special assistance please contact the District's Secretary at (714) 893-3553, at least one business day prior to the meeting so that we may accommodate you.

- 1. CALL TO ORDER, PLEDGE OF ALLEGIANCE AND INVOCATION**
- 2. ROLL CALL AND DECLARATION OF QUORUM**
- 3. PUBLIC COMMENTS**

All persons wishing to address the Board on specific Agenda items or matters of general interest should do so at this time. As determined by the President, speakers may be deferred until the specific item is taken for discussion and remarks may be limited to three (3) minutes.

4. APPROVAL OF THE MINUTES

- A. Approval of the Minutes of the Special Meeting (Strategic Planning) on April 11, 2024
- B. Approval of the Minutes of the Regular Meeting on April 16, 2024
- C. Approval of the Minutes of the Special Meeting (Budget Workshop) on April 30, 2024

5. REPORTS

The President, General Manager, Legal Counsel, and other staff present verbal reports on miscellaneous matters of general interest to the Directors. These reports are for information only and require no action by the Directors.

- A. Report of President
- B. Report of General Manager
- C. Report of Director of Services & Program Development
- D. Report of Radio Outreach with Me Vietnam on April 12, 2024
- E. Report of Radio Outreach with VietLink on April 18, 2024
- F. Report of Westminster Earth Day Event on April 20, 2024
- G. Report of District Employee Luncheon on April 24, 2024
- H. Report of OC San District Board of Directors Meeting on April 24, 2024
- I. Report of ISDOC Quarterly Luncheon Meeting on April 25, 2024
- J. Report of the District Community Workshop on April 27, 2024
- K. Report of Westminster Black April Remembrance Ceremony on April 30, 2024
- L. Report of WasteExpo Conference on May 7-9, 2024
- M. Report of Radio Outreach with Radio Bolsa on May 14, 2024
- N. Report of Radio Outreach with VNCR on May 16, 2024

6. CONSENT CALENDAR

All matters listed on the Consent Calendar are considered routine and will be acted upon at the same time unless separate discussion and/or action is requested by a Board Member, the public, or staff.

- A. Receive and File the Register of Demands in the Amount of \$3,395,407.45
- B. Approve and File the Treasurer's Investment Report for April 2024
- C. Receive and File the 3rd Quarter 2023-2024 Fiscal Year Financial and Budget Reports
- D. Approve the May 1, 2024 Outreach Committee Recommendations
- E. Receive and File the Engineer Report for April 2024
- F. Declare Four Class C Vehicles, One Sewer Vactor Truck, and Three Other Pieces of Equipment to be Surplus Property and Authorize the General Manager to Dispose of said Vehicles and Equipment Pursuant to the Methods Set Forth in the District's Purchasing Policy and Procedures
- G. Approve the April 10, 2024 Franchise Committee Report

7. OLD BUSINESS

None

8. NEW BUSINESS

- A. Discuss and Consider the Ballots for Orange County LAFCO Regular Special District Member Seat

B. RESOLUTION 2024-10

A RESOLUTION OF THE BOARD OF DIRECTORS OF THE MIDWAY CITY SANITARY DISTRICT OF ORANGE COUNTY (1) RATIFYING AND AUTHORIZING CONTINUED EMERGENCY ACTION FOR THE REPAIR, REPLACEMENT, AND LINING OF DAMAGED SEWER LINES, REMOVAL AND REPLACEMENT OF A MANHOLE, AND RELATED STREET REPAIRS IN WEBBER PLACE BETWEEN MANHOLE 2006 AND MANHOLE 2005 AND IN PEMBROOK LANE BETWEEN MANHOLE 2006 AND MANHOLE 2019; (2) RATIFYING AN AGREEMENT WITH PAULUS ENGINEERING, INC. AND RELATED CHANGE ORDER FOR A PORTION OF THE WORK; (3) APPROVING AND AUTHORIZING THE GENERAL MANAGER TO EXECUTE AN AGREEMENT WITH PERFORMANCE PIPELINE TECHNOLOGIES, INC. FOR A PORTION OF THE WORK; AND (4) FINDING THAT THE PROJECT IS STATUTORILY EXEMPT FROM REVIEW UNDER THE CALIFORNIA ENVIRONMENTAL QUALITY ACT *(Roll Call Vote)*

- C. Consider Approval of a Professional Service Agreement with AKM Consulting Engineers for Preparation of Plans and Specifications for Construction of Manholes Upstream and Downstream of the Inverted Siphon at Westminster Boulevard and Springdale Street
- D. Discussion of Election Information for the November 5, 2024 General Election and Transmittal of Election Information Special District

9. INFORMATIONAL ITEMS

- A. Special District Risk Management Authority (SDRMA) Board of Directors
- B. Final OC LAFCO FY 2024-25 Budget
- C. CalOES Letter of Support for Microgrid Project
- D. California Special Districts Association (CSDA) 2024 Climate Resilience Bond Priorities
- E. Support Request –Special District Grant Accessibility Act (H.R. 7525)

10. BOARD CONCERNS AND COMMENTS**11. GM/STAFF CONCERNS AND COMMENTS****12. GENERAL COUNSEL CONCERNS AND COMMENTS**

13. CLOSED SESSION ITEMS

CLOSED SESSION: During the course of conducting the business set forth on this agenda as a regular meeting of the Board, the Chair may convene the Board in closed session to consider matters of pending real estate negotiations, pending or potential litigation, or personnel matters, pursuant to Government Code Sections 54956.8, 54956.9, 54957 or 54957.6, as noted.

Reports relating to (a) purchase and sale of property; (b) matters of pending or potential litigation; (c) employment actions or negotiations with employee representatives; or which are exempt from public disclosure under the California Public Records Act, may be reviewed by the Board during a permitted closed session and are not available for public inspection. At such time as the Board takes final action on any of these subjects, the minutes will reflect all required disclosures of information.

- A. CONFERENCE WITH LEGAL COUNSEL – EXISTING LITIGATION
(Gov Code § 54956.9 (d)) Jonathan H. Cannon et al v. Midway City Sanitary District
(Case No. 8:21-CV-01072 DOC (ADSx))

14. ADJOURNMENT TO TUESDAY, JUNE 4, 2024

**MINUTES OF THE SPECIAL MEETING OF THE
BOARD OF DIRECTORS OF THE MIDWAY CITY
SANITARY DISTRICT OF ORANGE COUNTY
14451 CEDARWOOD STREET
WESTMINSTER, CA 92683**

April 11, 2024

CALL TO ORDER:

President M. Nguyen called the special meeting of the Governing Board of the Midway City Sanitary District to order at 14451 Cedarwood Street, Westminster, California on Thursday, April 11, 2024 at 5:36 PM.

BOARD MEMBERS PRESENT:

Mark Nguyen
Tyler Diep
Andrew Nguyen
Sergio Contreras
Chi Charlie Nguyen (arrived @ 5:49 PM)

STAFF MEMBERS PRESENT:

Robert Housley, General Manager
Ashley Davies, Director of Servs. & Program Development
Cynthia Olsder, Executive/Board Secretary
Nicolas Castro, Director of Operation & Safety

OTHERS PRESENT:

James H. Eggart, General Counsel Woodruff & Smart

PLEDGE OF ALLEGIANCE AND INVOCATION:

President M. Nguyen led the Pledge of Allegiance. Director S. Contreras gave the Invocation.

PUBLIC COMMENTS:

None

NEW BUSINESS:

A. Strategic Planning Workshops

GM, R. Housley gave a presentation and talked about the strategic plan for the District. He discussed the District's financial position, investment opportunities, trash and sewer rates, and shared a few of his planned projects for the District. Additionally, he discussed the ongoing and upcoming sewer and building infrastructure projects at the District.

Director of Operation & Safety, Nicolas Castro gave a presentation and provided an overview of the department of operations, solid waste, sewer maintenance, fleet maintenance, and current goals.

Director of Servs. & Program Development, Ashley Davies gave a presentation and covered several topics, including the customer service survey project, ways to strengthen the bond with the City of Westminster Code Enforcement, ways to increase outreach opportunities with the Oceanview School District, ways to increase awareness of F.O.G. (fat, oil, and grease), and ways to collaborate with other agencies to promote SB 1383 and AB 341.

No action was taken.

BOARD CONCERNS AND COMMENTS:

Director C. Nguyen recommended condensing and shortening the meeting.

Director S. Contreras suggested that Staff compare the cost charged for all waste services with surrounding agencies to have a better understanding of the trash fees.

President M. Nguyen and Director A. Nguyen thanked Staff for presenting.

GM/STAFF CONCERNS AND COMMENT:

None.

GENERAL COUNSEL CONCERNS AND COMMENTS:

None.

ADJOURNMENT:

President M. Nguyen adjourned the meeting at 7:28 P.M.

Andrew Nguyen, Secretary

**MINUTES OF THE REGULAR MEETING OF THE
BOARD OF DIRECTORS OF THE MIDWAY CITY
SANITARY DISTRICT OF ORANGE COUNTY
14451 CEDARWOOD STREET
WESTMINSTER, CA 92683**

April 16, 2024

CALL TO ORDER:

President M. Nguyen called the regular meeting of the Governing Board of the Midway City Sanitary District to order at 14451 Cedarwood Street, Westminster, California on Tuesday, April 16, 2024 at 5:34 P.M.

BOARD MEMBERS PRESENT:

Mark Nguyen
Tyler Diep
Sergio Contreras
Andrew Nguyen

STAFF MEMBERS PRESENT:

Robert Housley, General Manager
Ashley Davies, Director of Servs. & Program Development
Milo Ebrahimi, District Engineer, P.E
Cynthia Olsder, Executive/Board Secretary

BOARD MEMBERS ABSENT:

Chi Charlie Nguyen

OTHERS PRESENT:

James H. Eggart, General Counsel Woodruff & Smart
Brian Hamblet, Burke, Williams, Sorensen, LLP

PLEDGE OF ALLEGIANCE AND INVOCATION:

Director T. Diep led the Pledge of Allegiance. Director S. Contreras gave the Invocation.

PUBLIC COMMENTS:

None.

APPROVAL OF THE MINUTES OF THE REGULAR MEETING ON APRIL 2, 2024

A motion was made by Director T. Diep, seconded by Director A. Nguyen, to approve the minutes of the regular meeting on April 2, 2024. The motion was approved by the following 4-0 vote:

AYES: A. Nguyen, M. Nguyen, T. Diep, S. Contreras

NAYS:

ABSTAIN:

ABSENT: C. Nguyen

REPORTS:

Report of President

None.

Report of General Manager

GM R. Housley provided updates on events occurring at the District. He reported on the District's sewer system in detail.

Report of Director of Services & Program Development

Director of Services & Program Development A. Davies reported on three events: the Clean-up event at Sigler Park, the Westminster City Earth Day event on April 20, 2024, and the Clean-up event at Bolsa Chica in June.

Report of Outreach Committee Meeting on April 3, 2024

Director T. Diep and Director C. Nguyen attended the meeting to plan and prepare for the upcoming 85th Anniversary event and the Compost event.

Report of Franchise Committee Meeting on April 10, 2024

Director T. Diep and Director C. Nguyen attended the meeting to discuss current and future outreach opportunities with CR&R staff.

Report of Clean-up event at Sigler Park on April 13, 2024

President M. Nguyen, Director T. Diep, and Director A. Nguyen attended the event and reported that there was such a large turnout that the District had to request for the delivery of an additional bin from CR&R.

Report of Special District Leadership Academy (SDLA) on April 15-16, 2024

Director A. Nguyen and GM R. Housley attended the conference and expressed that this was an excellent chance to network in order to raise awareness within our field and to gain access to resources and support.

CONSENT CALENDAR:

- A. Receive and File the Register of Demands in the Amount of \$1,250,841.44
- B. Approve and File the Treasurer's Investment Report for March 2024
- C. Approve the April 3, 2024 Outreach Committee Recommendations
- D. Receive and File the Engineer Report for March 2024
- E. Approve a \$1000 Safety Award to Utility/Relief Driver, Juan Arvizu Sr. for Protecting the Community and Saving Solid Waste Truck NG-13 from a Fire on March 19, 2024
- F. Approve and Authorize the General Manager to Execute a Professional Services Agreement with Procure America for Cost Recovery and Reduction Services in the Areas of Utilities and Treasury Services

A motion was made by Director T. Diep, seconded by Director S. Contreras, to approve the Consent Calendar. The motion was approved by the following 4-0 vote:

AYES: A. Nguyen, M. Nguyen, T. Diep, S. Contreras

NAYS:

ABSTAIN:

ABSENT: C. Nguyen

OLD BUSINESS:

None.

NEW BUSINESS:

A. A RESOLUTION NO. 2024-08 OF THE BOARD OF DIRECTORS OF THE MIDWAY CITY SANITARY DISTRICT OF ORANGE COUNTY, CALIFORNIA, ESTABLISHING A POLICY APPLICABLE TO DISTRICT DEPOSITS AND INVESTED FUNDS

A staff report and recommendations were provided to and considered by the Board. A motion was made by Director T. Diep, seconded by Director S. Contreras, to adopt Resolution No. 2024-08 as presented at the meeting. The motion was approved by the following 4-0 roll call vote:

AYES: A. Nguyen, M. Nguyen, S. Contreras, T. Diep,

NAYS:

ABSTAIN:

ABSENT: C. Nguyen

B. A RESOLUTION NO. 2024-09 OF THE BOARD OF DIRECTORS OF THE MIDWAY CITY SANITARY DISTRICT OF ORANGE COUNTY, CALIFORNIA, APPROVING THE ANNUAL STATEMENT OF INVESTMENT POLICY FOR FISCAL YEAR 2024-2025 (JULY 1, 2024 THROUGH JUNE 30, 2025)

A staff report and recommendations were provided to and considered by the Board. A motion was made by Director T. Diep, seconded by Director S. Contreras, to adopt Resolution No. 2024-09 as presented at the meeting. The motion was approved by the following 4-0 roll call vote:

AYES: A. Nguyen, M. Nguyen, S. Contreras, T. Diep,

NAYS:

ABSTAIN:

ABSENT: C. Nguyen

INFORMATIONAL ITEMS:

A. ISDOC Quarterly Luncheon – April 25, 2024

Receive and File.

BOARD CONCERNS AND COMMENTS:

The Directors thanked the staff.

GM/STAFF CONCERNS AND COMMENT:

GM R. Housley thanked the Board for their support.

GENERAL COUNSEL CONCERNS AND COMMENTS:

General Counsel J. Eggart shared the most recent impact fee ruling from the U.S. Supreme Court, which ruled that developers and home builders in California may contest the fees commonly imposed by cities and counties to pay for new roads, schools, sewers, and other public improvements.

General Counsel, J. Eggart announced that, due to a conflict of interest, he would not be participating in the closed session, and that the closed session would be handed by the District's outside counsel.

With the consent of the full Board, General Counsel, J. Eggart convened the meeting to closed session at 5:52 P.M. for consideration of the following matter identified on Agenda pursuant to applicable law.

General Counsel, J. Eggart left the room.

CLOSED SESSION:

CLOSED SESSION: During the course of conducting the business set forth on this agenda as a regular meeting of the Board, the Chair may convene the Board in closed session to consider matters of pending real estate negotiations, pending or potential litigation, or personnel matters, pursuant to Government Code Sections 54956.8, 54956.9, 54957 or 54957.6, as noted.

Reports relating to (a) purchase and sale of property; (b) matters of pending or potential litigation; (c) employment actions or negotiations with employee representatives; or which are exempt from public disclosure under the California Public Records Act, may be reviewed by the Board during a permitted closed session and are not available for public inspection. At such time as the Board takes final action on any of these subjects, the minutes will reflect all required disclosures of information.

A. CONFERENCE WITH LEGAL COUNSEL – EXISTING LITIGATION

(Gov Code § 54956.9 (d)) Jonathan H. Cannon et al v. Midway City Sanitary District
(Case No. 8:21-CV-01072 DOC (ADSx))

President M. Nguyen reconvened the open session portion of the meeting at 6:02 P.M.

President M. Nguyen reported that the Board had met in closed session as identified on Agenda Item 14A, and that no reportable action had been taken.

ADJOURNMENT:

President M. Nguyen adjourned the meeting at 6:02 P.M. to the next Board Meeting to be held at the District on Tuesday, May 21, 2024, at 5:30 P.M.

Andrew Nguyen, Secretary

**MINUTES OF THE SPECIAL MEETING OF THE
BOARD OF DIRECTORS OF THE MIDWAY CITY
SANITARY DISTRICT OF ORANGE COUNTY
14451 CEDARWOOD STREET
WESTMINSTER, CA 92683**

April 30, 2024

CALL TO ORDER:

President M. Nguyen called the special meeting of the Governing Board of the Midway City Sanitary District to order at 14451 Cedarwood Street, Westminster, California on Tuesday, April 30, 2024 at 5:33 PM.

BOARD MEMBERS PRESENT:

Mark Nguyen
Chi Charlie Nguyen
Andrew Nguyen
Sergio Contreras
Tyler Diep

STAFF MEMBERS PRESENT:

Robert Housley, General Manager
Ashley Davies, Director of Servs. & Program Development
Nicolas Castro, Director of Operations & Safety
Milo Ebrahimi, District Engineer, P.E
Cynthia Olsder, Executive/Board Secretary

OTHERS PRESENT:

James H. Eggart, General Counsel Woodruff & Smart

PLEDGE OF ALLEGIANCE AND INVOCATION:

Director S. Contreras led the Pledge of Allegiance. Director C. Nguyen gave the Invocation.

PUBLIC COMMENTS:

None

NEW BUSINESS:

- A. Budget Workshop – Overview of the Fiscal Year 2024-2025 Operating Budget, Capital Improvement Projects, Net Position, and Reserves

GM, R. Housley gave a presentation. He discussed the District’s overview of the Fiscal Year 2024-2025 operating budget, capital improvement projects, net position, and reserves.

No action was taken.

BOARD CONCERNS AND COMMENTS:

Director C. Nguyen expressed gratitude to the Directors and Staff for supporting the City of Westminster.

President M. Nguyen and Director A. Nguyen thanked Staff.

GM/STAFF CONCERNS AND COMMENTS:

GM R. Housley reminded the Board of all the District’s upcoming events and activities.

GENERAL COUNSEL CONCERNS AND COMMENTS:

None.

ADJOURNMENT:

President M. Nguyen adjourned the meeting at 6:35 P.M.

Andrew Nguyen, Secretary

AGENDA ITEM #6A

Date: May 21, 2024

To: Board of Directors

From: Robert Housley, General Manager

Prepared by: Mariana Sanchez, Accountant

Subject: Receive and File the Register of Demands in the Amount of \$3,395,407.45

BACKGROUND

The laws of the State of California governing Special Districts provide that the Midway City Sanitary District Board of Directors shall review for approval all payments made by the District.

A Register of Demands is provided at each regular Midway City Sanitary District Board Meeting describing each payment made or to be made by the district during the specified period. The report is designed to communicate fiscal activity based on adopted and approved budget appropriations.

The Treasurer has duly reviewed the demands on the attached register.

FISCAL IMPACT

The total value of demand for this period is \$3,395,407.45. This includes expenses, payroll, and payroll-related disbursements.

Sufficient funds are available to process all payments.

STAFF RECOMMENDATION

Staff recommends that the Board of Directors review and file the attached Register of Demands.

ATTACHMENTS:

1. Disbursement Details for May 21, 2024.

Midway City Sanitary District

Accounts Payable Expenditures, Payments, Payroll, and ACH Payment(s) Report

Prepared for Board Meeting held on May 21, 2024

Type	Num	Date	Name	Memo	Paid Amount
Check	15573	04/12/2024	Ayala's Car Wash		
Bill	2140	04/08/2024		Fleet Wash (2) 04/08/24	80.00
				Fleet Wash (8) 04/08/24	320.00
Bill	2144	04/10/2024		Fleet Wash (3) 04/10/24	90.00
				Fleet Wash (1) 04/10/24	30.00
				Fleet Wash (3) 04/10/24	90.00
				Fleet Wash (3) 04/10/24	90.00
					700.00
Check	15574	04/12/2024	Betts Truck Parts & Service	PO #	
Bill	05RO3102	04/03/2024		Repair Walking Beam Bushings for NG-5	1,580.20
					1,580.20
Check	15575	04/12/2024	Cameron Welding Supply	PO# 28438	
Bill	1626644-00	04/02/2024		Propane, Liquefied (1), ER70S6 035 33#SP wire (33)	148.61
					148.61
Check	15576	04/12/2024	Cascade Engineering, Inc.	Sales Order: C435531	
Bill	241004175	03/25/2024		Black Carts (840)	46,218.25
					46,218.25
Check	15577	04/12/2024	City of Westminster	2023 Q3 & Q4 Over The Top Fees	
Bill	2023 Q3 & Q4	12/31/2023		2023 Q4 Over The Top Fees - Oct-Dec	585.00
					585.00
Check	15578	04/12/2024	Daniels Tire Service	Cust # 2002338 Ref # 892491	
Bill	200501768	04/10/2024		Recap Tires (8)	1,946.49
					1,946.49
Check	15579	04/12/2024	Dartco Transmission Sales & Srvs.	Customer # 0343701 PO# 28451	
Bill	C273989	04/11/2024		Filter Kit (12)	1,111.36
					1,111.36
Check	15580	04/12/2024	HB Staffing/Cathyjon Enterprises, Inc.	Client# 341347	
Bill	4365713	04/04/2024		Administrative Assistant 03/26/24 - 03/28/24	716.63
					716.63
Check	15581	04/12/2024	Hydraulic Solutions And Supplies		
Bill	127064	04/03/2024		Heil Dump Cylinder RB Exchange (2), Heil Dump Arm Cylinder New (1)	1,151.21
					1,151.21
Check	15582	04/12/2024	Merchants Building Maintenance, LLC	Cust # 33114	
Bill	795883	04/01/2024		Janitorial Services April - 2024	853.21
					853.21
Check	15583	04/12/2024	Peckham & McKenney	Invoice #2	
Bill	04.11.2024	04/11/2024		Professional Fee Retainer Invoice# 2 - Director of Finance/HR search	9,333.33
					9,333.33
Check	15584	04/12/2024	Quality Service Plus, Inc.	Customer# 11306	
Bill	88511	04/08/2024		RTA Cut Vinyl Solyx Window Film and Installation	1,130.63
					1,130.63
Check	15585	04/12/2024	SDRMA - Employee Benefits	Member # 7732	
Bill	H44734	05/01/2024		May - 2024	614.09
				May - 2024	1,498.25
				May - 2024	813.70
				May - 2024	527.36
				May - 2024	453.41
				May - 2024	113.93
				May - 2024	235.36
				May - 2024	97.42
				May - 2024	98.48
				May - 2024	48.71
					4,500.71
Check	15586	04/12/2024	SoCal Auto & Truck Parts, Inc.		
Bill	606779	04/02/2024		LED Lights (8)	347.40
Bill	606874	04/03/2024		Striping Machine (1)	269.55
				Striping Paint Yellow (6), Striping Paint White (6), Air Filter (3)	218.66

Midway City Sanitary District

Accounts Payable Expenditures, Payments, Payroll, and ACH Payment(s) Report

Prepared for Board Meeting held on May 21, 2024

Type	Num	Date	Name	Memo	Paid Amount
					835.61
Check	15587	04/12/2024	South Coast Air Quality Management Dist.		
Bill	4325246	03/19/2024		I C E (50-500 HP) Em Elec Gen-Diesel	504.91
Bill	4325247	03/19/2024		I C E (50-500 HP) EM Elec Generator - Diesel	504.91
Bill	4327451	03/19/2024		FY 23-24 Flat Fee for Last Fiscal Year Emissions	160.35
Bill	4327452	03/19/2024		FY 23-24 Flat Fee for Last Fiscal Year Emissions	160.35
					1,330.52
Check	15588	04/12/2024	Southwest Patrol, Inc.		
Bill	75246	03/31/2024		Patrol Service 3/15/24 - 3/31/24	743.00
					743.00
Check	15589	04/12/2024	SWRCB	Fac Id 8 30I005637	
Bill	SW-0293093	04/03/2024		Annual Permit Fees for 04/01/24 - 03/31/25	1,673.00
					1,673.00
Check	15590	04/12/2024	TEC Of California, Inc.		
Bill	1437975L	03/22/2024		Door Handle (2) - one used on NG-2	102.97
Bill	1440349L	04/08/2024		Tie Rod Ends (4)	294.24
Bill	1440498L	04/09/2024		Filter (6), Foot Brake (2)	738.35
Bill	1439705L	04/09/2024		Brake Pad (6)	2,471.63
Bill	1440982L	04/11/2024		Lube Filter (4), Fuel Filter (5)	360.05
					3,967.24
Check	15591	04/12/2024	UniFirst Corporation		
Bill	2190153614	04/05/2024		April - 2024	190.85
Bill	2190153616	04/05/2024		April - 2024	77.24
Bill	2190153619	04/05/2024		April - 2024	69.66
Bill	2190153620	04/05/2024		April - 2024	16.23
					353.98
Check	15592	04/12/2024	Woodruff & Smart	ID: 2003-JHE	
Bill	75813	03/31/2024		Legal Services Mar-2024	9,103.20
					9,103.20
Check	15593	04/19/2024	AT&T Mobility (First Net)	Acct # 287291683611	
Bill	287291683611X041024	04/02/2024		March 2024	372.21
				March 2024	137.13
				March 2024	91.42
					600.76
Check	15594	04/19/2024	Ayala's Car Wash	Fleet Wash 0/15/24	
Bill	2146	04/15/2024		Fleet Wash (9) 04/15/24	360.00
					360.00
Check	15595	04/19/2024	City of Westminster Hydrant	Acct #013-0012-00 Customer #045973	
Bill	87523 04/15/24	04/15/2024		Hydrant Water Service Apr-2024	84.94
					84.94
Check	15596	04/19/2024	Daniels Tire Service	Cust # 2002338 Ref # 893774	
Bill	200502244	04/17/2024		Recap Tires (2)	491.34
					491.34
Check	15597	04/19/2024	ehs International, Inc	Course ID: 9765	
Bill	3-20621	04/18/2024		CPR/First Aid/AED	1,485.00
					1,485.00
Check	15598	04/19/2024	HB Staffing/Cathyjon Enterprises, Inc.	Client# 341347	
Bill	4369544	04/11/2024		Administrative Assistant 04/02/24 - 04/04/24	716.63
					716.63
Check	15599	04/19/2024	NRI Portfolios, LLC	Overpayment of fees for Permit# 7395	
Bill	Permit# 7395	04/15/2024		Overpayment of fees for Permit# 7395	200.00
					200.00
Check	15600	04/19/2024	Orange County Treasurer-Tax Collector	WEROC/Emergency Radio	
Bill	STCS002129	04/16/2024		WEROC Emergency Radio 04/01/2024 - 06/30/2024	127.25

Midway City Sanitary District

Accounts Payable Expenditures, Payments, Payroll, and ACH Payment(s) Report

Prepared for Board Meeting held on May 21, 2024

Type	Num	Date	Name	Memo	Paid Amount
					127.25
Check	15601	04/19/2024	Pitney Bowes/Purchase Power	Acct # 80000-90000-0933-5138	
Bill	80009000093351380424	03/31/2024		Postage March-2024	100.00
					100.00
Check	15602	04/19/2024	Radio Bolsa Corp.	BS 2023_2027d	
Bill	4280	03/31/2024		Radio talkshows (6) 20Min Recorded 03/20/24 - 3/29/24	2,000.00
					2,000.00
Check	15603	04/19/2024	Rutan & Tucker, LLP	Account # 014843-0001	
Bill	989970	03/31/2024		Legal Services Mar-2024	406.00
					406.00
Check	15604	04/19/2024	Shuster Advisory Group, LLC	Q1 2024 Advisory Fee for 457(b) & OBRA Plans	
Bill	5201	03/31/2024		Advisory Fee for 457(b) & OBRA plans Q1 2024	1,300.00
					1,300.00
Check	15605	04/19/2024	SoCal Auto & Truck Parts, Inc.	PO# 28452	
Bill	607669	04/12/2024		Premium Capsules (4)	121.58
					121.58
Check	15606	04/19/2024	SoCalGas		
Bill	19170926059 041024	03/31/2024		District Offices March 2024	195.51
Bill	19380926006 04102024	04/10/2024		Maint. Shop & Wash Rack - Apr 2024	32.06
					227.57
Check	15607	04/19/2024	Staples Business Credit	Acct # 10181543LA	
Bill	7000202778	03/26/2024		Office Supplies Mar-2024	897.16
					897.16
Check	15608	04/19/2024	UniFirst Corporation		
Bill	2190157704	04/12/2024		April - 2024	190.85
Bill	2190157705	04/12/2024		April - 2024	144.08
Bill	2190157706	04/12/2024		April - 2024	69.66
Bill	2190157707	04/12/2024		April - 2024	16.23
					420.82
Check	15609	04/24/2024	Eduardo Ceja	District Luncheon 2024_04_24	
Bill	20240424	04/24/2024		Tacos for April Employee Lunch 04/24	650.00
					650.00
Check	15610	04/26/2024	AT&T (Brookhurst Lift Station)	Acct # 714 531-0272 115 1	
Bill	7145310272 04/24	04/19/2024		Brookhurst Apr-2024	599.48
					599.48
Check	15611	04/26/2024	Ayala's Car Wash	Fleet Wash 04/22/24	
Bill	1591	04/22/2024		Fleet Wash (2) 04/22/24	80.00
				Fleet Wash (8) 04/22/24	320.00
					400.00
Check	15612	04/26/2024	Bodyworks Equip. Inc.	PO# 28455	
Bill	47047	04/19/2024		Spring (10), Rocker Switch (20), 2" Cam Follower (10), 2" Cam Follower (2), 30MM Sourcing Switch...	2,429.49
					2,429.49
Check	15613	04/26/2024	Business Radio Licensing		
Bill	WQVD646	04/22/2024		FCC License Renewal - WQVD646	115.00
Bill	KNFF494	04/22/2024		FCC License Renewal - KNFF494	115.00
					230.00
Check	15614	04/26/2024	Cameron Welding Supply		
Bill	1626644-00a	04/02/2024		Balance due - Propane, Liquefied (1), ER70S6 035 33#SP wire (33)	10.00
Bill	1631036-00	04/23/2024		Oxygen, Compressed (1), CO2, Compressed (1), Miller Helmet Battery (2), REVCO Mig Glove (1), ER7...	400.77
					410.77
Check	15615	04/26/2024	City of Westminster-Water Billing		
Bill	8451607 0324	04/23/2024		Westminster Lift Station 02/14/24 - 04/15/24	20.23

Midway City Sanitary District

Accounts Payable Expenditures, Payments, Payroll, and ACH Payment(s) Report

Prepared for Board Meeting held on May 21, 2024

Type	Num	Date	Name	Memo	Paid Amount
Bill	8456005 041624	04/23/2024		Hammon Lift Station 02/15/24 - 04/16/24	19.45
					39.68
Check	15616	04/26/2024	Clean Energy		
Bill	CEW12677594	04/22/2024		CNG Station Service 04/15/24	1,957.16
Bill	CEW12678646	04/24/2024		CNG Station Service 04/16/24	152.66
Bill	CEW12678650	04/24/2024		CNG Station Service 04/16/24	190.88
					2,300.70
Check	15617	04/26/2024	CR Transfer, Inc.		
Bill	45434	02/29/2024		Tonnage Fees Feb-2024 (782.18)	81,330.88
Bill	45400	02/29/2024		Tonnage Fees Feb-24 (1925.49)	120,784.40
Bill	45506	03/31/2024		Tonnage Fees Mar-2024 (989.63)	104,478.58
Bill	45474	03/31/2024		Tonnage Fees Mar-24 (1883.66)	118,704.81
					425,298.67
Check	15618	04/26/2024	Cummins Pacific LLC	PO# 28457	
Bill	X5-68786	04/23/2024		Kit, Exh RCN Valve (1)	1,110.31
					1,110.31
Check	15619	04/26/2024	ECIS	GCDI	
Bill	MCSDGCDI124	03/31/2024		FOG Inspections Mar-2024 (342)	8,550.00
					8,550.00
Check	15620	04/26/2024	Four Pals, Inc.	Project # 14451 Cedarwood	
Bill	4P56500	04/08/2024		Backflow testing Cedarwood (3) Westminster (1), Hammon (1)	255.00
					255.00
Check	15621	04/26/2024	Haaker Equipment Co.	Customer # 129 PO# NG-16	
Bill	W1A7M8	04/16/2024		Repairs to NG-16 Vector Truck	2,524.51
					2,524.51
Check	15622	04/26/2024	HB Staffing/Cathyjon Enterprises, Inc.	Client# 341347	
Bill	4373426	04/18/2024		Administrative Assistant 04/09/24 - 04/11/24	716.63
					716.63
Check	15623	04/26/2024	Motion and Flow Control Products, Inc.	PO # 28460 ID#176382	
Bill	9088911	04/22/2024		Crimp, 1/4" Female (10), Parker Female JIC (4)	156.97
					156.97
Check	15624	04/26/2024	NVB Equipment, Inc.	PO# NG-18	
Bill	SQ16046	04/24/2024		A/C Service & Repairs for NG-18	1,349.07
					1,349.07
Check	15625	04/26/2024	PeopleSpace	Sales Order# SO1058656	
Bill	INV88527	04/19/2024		50% Due after install	2,341.24
					2,341.24
Check	15626	04/26/2024	Pre-Paid Legal Services, Inc.	Group #155124	
Bill	155124 042524	04/25/2024		Prepaid Legal Apr-2023	33.90
					33.90
Check	15627	04/26/2024	Safety-Kleen Systems, Inc.	Customer# MI47237	
Bill	94417791	04/23/2024		MV ATF Dex/Mer (65 gallons), NGENO 15W-40 (88 gallons)	2,594.76
					2,594.76
Check	15628	04/26/2024	SDRMA - Property/Liability	Member #7732	
Bill	75100	04/01/2024		Ins: 2024 Mack LR64E Vin: 1M2LR7GC7RM002468	1,202.11
				Ins: 2024 Mack LR64E Vin: 1M2LR7GC5RM002467	1,202.10
					2,404.21
Check	15629	04/26/2024	SoCal Auto & Truck Parts, Inc.	PO# 28455	
Bill	608299	04/19/2024		Spin-On Fluid Filter (2) for M-1	11.43
					11.43
Check	15630	04/26/2024	Southern California Edison	Acct # 700472251517	
Bill	700472251517 041924	04/19/2024		Willow Apr-2024	292.00
				Brookhurst Apr-2024	108.76
				Hammon Apr-2024	960.68
				Westminster Apr-2024	1,323.00

Midway City Sanitary District

Accounts Payable Expenditures, Payments, Payroll, and ACH Payment(s) Report

Prepared for Board Meeting held on May 21, 2024

Type	Num	Date	Name	Memo	Paid Amount
				Cedarwood Apr-2024	6,213.58
					8,898.02
Check	15631	04/26/2024	Spectrum Enterprise (Time Warner Cable	Acct # 8448 40 013 1162435	
Bill	1162435041024	04/09/2024		Apr-2024	1,349.00
					1,349.00
Check	15632	04/26/2024	Spectrum Enterprise (Time Warner Cable	Acct # 8448 40 013 0973956	
Bill	0973956042024	04/20/2024		Apr-2024	102.04
					102.04
Check	15633	04/26/2024	Standard Insurance Company Life	Policy # 00 141873 0003	
Bill	001417830003 05/2024	05/01/2024		May - 2024	559.36
				May - 2024	196.32
				May - 2024	238.96
				May - 2024	424.40
				May - 2024	96.00
				Adj - May - 2024	5.04
					1,520.08
Check	15634	04/26/2024	TEC Of California, Inc.	PO # 28459	
Bill	1440486L	04/22/2024		Torque Rod (4)	805.30
					805.30
Check	15635	04/26/2024	UniFirst Corporation		
Bill	2190160774	04/19/2024		April - 2024	190.85
Bill	2190160775	04/19/2024		April - 2024	82.21
Bill	2190160776	04/19/2024		April - 2024	69.66
Bill	2190160777	04/19/2024		April - 2024	16.23
					358.95
Check	15636	04/26/2024	Woodcliff Corporation - Contractor	Project No: 202041	
Bill	Solar #04 022024	04/04/2024		Solar Project Pay App #4 02/2024	63,400.85
					63,400.85
Check	15637	04/26/2024	Woodcliff Corporation - Escrow Account	Account No. 3586554618	
Bill	022024 3586554618	04/04/2024		Solar Project #4 February 2024 - Retention Payment	3,336.89
					3,336.89
Check	15638	05/01/2024	Ayala's Car Wash		
Bill	2147	04/24/2024		Fleet Wash (3) 04/24/24	90.00
				Fleet Wash (1) 04/24/24	30.00
				Fleet Wash (3) 04/24/24	90.00
				Fleet Wash (3) 04/24/24	90.00
Bill	2148	04/29/2024		Fleet Wash (9) 04/29/24	360.00
					660.00
Check	15639	05/01/2024	Carmen Perron	Refund	
Bill	04.30.2024	04/30/2024		Refund charge for additional black container	38.07
					38.07
Check	15640	05/01/2024	CRC Cloud	MCSD	
Bill	2102956	05/01/2024		Maintenance & Support May-2024	2,513.00
					2,513.00
Check	15641	05/01/2024	Frontier Communications	Acct # 209-188-5155-071808-5	
Bill	MCSD 04/19/2024	04/19/2024		(714)903-1863 Willow Apr - 2024	187.93
				(714)903-6154 Westminster Ar - 2024	189.70
				(714)903-6274 Hammon Apr - 2024	187.74
				(714)897-5136 District Offices Apr - 2024	99.61
					664.98
Check	15642	05/01/2024	Hillco Fastener Warehouse Inc.	Order No. 01382854	
Bill	5377052	04/26/2024		7" Black Nylon Wire Tie (200)	21.55
					21.55
Check	15643	05/01/2024	Snap-On Tools	PO # 28465	
Bill	04242488982	04/24/2024		6IN Std Orb Palm Sander	422.98
					422.98
Check	15644	05/01/2024	SoCal Auto & Truck Parts, Inc.	PO#	
Bill	608855	04/26/2024		Miniature Bulb (20)	14.80
					14.80

Midway City Sanitary District

Accounts Payable Expenditures, Payments, Payroll, and ACH Payment(s) Report

Prepared for Board Meeting held on May 21, 2024

Type	Num	Date	Name	Memo	Paid Amount
Check	15645	05/01/2024	TEC Of California, Inc.	PO # 28467	
Bill	1443181L	04/29/2024		Wear Pad (20)	114.00
					114.00
Check	15646	05/01/2024	Tesco Controls, Inc.	Cust # MIDW/C QT # 23L106Q01	
Bill	0082062-IN	01/31/2024		Preventative Maintenance for SCADA System 1/1/24 - 12/31/24	4,500.00
					4,500.00
Check	15647	05/01/2024	UniFirst Corporation		
Bill	2190164047	04/26/2024		April - 2024	190.85
Bill	2190164049	04/26/2024		April - 2024	77.24
Bill	2190164050	04/26/2024		April - 2024	69.66
Bill	2190164051	04/26/2024		April - 2024	16.23
					353.98
Check	15648	05/01/2024	Woodcliff Corporation - Contractor	Project No: 202041	
Bill	Building #16 Apr-24	04/16/2024		Building Project Pay App #16 Apr 2024	75,725.37
Bill	Building #17 Apr-24	04/16/2024		Building Project Pay App #17 Apr 2024	30,372.51
					106,097.88
Check	15649	05/13/2024	AKM Consulting Engineers, Inc.	Project No. 2351831.00	
Bill	0012805	05/01/2024		Sewer System Master Plan 04/01/24 - 04/26/24	40,424.50
					40,424.50
Check	15650	05/13/2024	Ann Gutierrez		
Bill	Refund	05/08/2024		Fee Refund - Container never delivered	38.07
					38.07
Check	15651	05/13/2024	Bodyworks Equip. Inc.	PO# 0503NG-9	
Bill	47178	05/03/2024		Electrical repairs to NG-9	2,056.84
					2,056.84
Check	15652	05/13/2024	City of Westminster FARP	Acct # 1755 False Alarm Fine	
Bill	199288	04/19/2024		False Alarm Fine - 4/9/24	75.00
					75.00
Check	15653	05/13/2024	CR&R Incorporated	Acct # 63-0001259-2	
Bill	181141	04/30/2024		Clean-Up Event Sigler Park 4/13/24	2,441.19
					2,441.19
Check	15654	05/13/2024	Dtntech	Bolsa Chica Park Cleanup Mailer	
Bill	QU-2117	05/01/2024		Bolsa Chica Park Cleanup Mailer (3397)	2,214.27
					2,214.27
Check	15655	05/13/2024	Empire Pipe Cleaning and Equipment, Inc.		
Bill	12574	04/10/2024		04-10-24 CCTV Inspection Pembroke & Webber	1,687.50
Bill	12573	04/17/2024		CCTV Video Inspection & Cleaning Project	263,630.37
					265,317.87
Check	15656	05/13/2024	Four Pals, Inc.	Project # 14240 Hammond Pl.	
Bill	4P56686	05/10/2024		Backflow testing Hammond (5)	1,250.00
					1,250.00
Check	15657	05/13/2024	Merchants Building Maintenance, LLC	Cust # 33114	
Bill	801241	05/01/2024		Janitorial Services May - 2024	853.21
					853.21
Check	15658	05/13/2024	PumpMan	SRO0004907	
Bill	803060	04/29/2024		Q4 Lift Stations Maintenance 04-06/2024	11,536.00
					11,536.00
Check	15659	05/13/2024	Rutan & Tucker, LLP	Account # 014843-0001	
Bill	992128	04/30/2024		Legal Services Apr-2024	1,334.00
					1,334.00
Check	15660	05/13/2024	SDRMA - Employee Benefits	Member # 7732	
Bill	H45208	06/01/2024		June - 2024	614.09
				June - 2024	1,498.25

Midway City Sanitary District

Accounts Payable Expenditures, Payments, Payroll, and ACH Payment(s) Report

Prepared for Board Meeting held on May 21, 2024

Type	Num	Date	Name	Memo	Paid Amount
				June - 2024	813.70
				June - 2024	527.36
				June - 2024	453.41
				June - 2024	113.93
				June - 2024	235.36
				June - 2024	97.42
				June - 2024	98.48
				June - 2024	48.71
					4,500.71
Check	15661	05/13/2024	SoCal First Aid & Safety		
Bill	42-103742	05/01/2024		Restock first aid kits	407.55
					407.55
Check	15662	05/13/2024	South Coast Air Quality Management Dist.		
Bill	4350068	04/16/2024		AQMD Hot Spot Fee 07/23 -06/24	161.81
Bill	4350069	04/16/2024		AQMD Hot Spot Fee 07/23-06/24	161.81
Bill	4346347	04/16/2024		AQMD Hot Spot Fee 07/23 - 06/24	161.81
					485.43
Check	15663	05/13/2024	Southern California Edison	Acct # 700472251517	
Bill	700472251517 042924	04/29/2024		Cedarwood 4/18/24 - 4/21/24	796.26
					796.26
Check	15664	05/13/2024	TEC of California, Inc. - Trucks	2024 MACK LR64E	
Bill	MX4920	02/13/2024		NG-21 Mack Truck Side Loader 2024 Vin #1M2LR7GC5RM002467 (NG-21)	449,339.20
					449,339.20
Check	15665	05/13/2024	Tesco Controls, Inc.		
Bill	0081888-IN	01/11/2024		SCADA Relocation Services	4,080.00
Bill	0082005-IN	01/24/2024		SCADA Relocation Services	9,520.00
					13,600.00
Check	15666	05/13/2024	Townsend Public Affairs, Inc.		
Bill	21642	05/01/2024		2nd Installment - Community Project Funding Advocacy Services	4,000.00
					4,000.00
Check Total					\$1,547,770.52
ACH Payment	90280410202	04/10/2024	Chevron Texaco (Wex Bank)	Acct # 0496-00-525172-3	
Bill	96280982	03/31/2024		Mar-2024	156.07
				Mar-2024	219.09
				Mar-2024	93.18
				Mar-2024	675.51
					1,143.85
ACH Payment	1002622130	04/17/2024	CalPERS-Retirement	6882866561	
Bill	04/01/24 - 04/14/24	04/17/2024		Earned Period 04/01/24 - 04/14/24	1,857.81
				Earned Period 04/01/24 - 04/14/24	3,083.13
				Earned Period 04/01/24 - 04/14/24	3,563.80
				Earned Period 04/01/24 - 04/14/24	1,359.28
					9,864.02
ACH Payment	1002622131	04/17/2024	CalPERS-Retirement	6882866561	
Bill	04/01/24 - 04/14/24	04/17/2024		Earned Period 04/01/24 - 04/14/24	1,603.64
				Earned Period 04/01/24 - 04/14/24	2,661.29
				Earned Period 04/01/24 - 04/14/24	3,076.20
				Earned Period 04/01/24 - 04/14/24	1,173.29
					8,514.42
ACH Payment	1002622132	04/17/2024	CalPERS-Retirement	6882866561	
Bill	04/01/24 - 04/14/24	04/17/2024		Earned Period 04/01/24 - 04/14/24	132.06
				Earned Period 04/01/24 - 04/14/24	219.17
				Earned Period 04/01/24 - 04/14/24	253.34
				Earned Period 04/01/24 - 04/14/24	96.63
					701.20
ACH Payment		04/17/2024		Funds Transfer 457(b) Salary Reduction	
				Funds Transfer 457(b) Salary Reduction	3,523.25
					3,523.25
ACH Payment		04/17/2024		Funds Transfer 457(b) Roth	

Midway City Sanitary District

Accounts Payable Expenditures, Payments, Payroll, and ACH Payment(s) Report

Prepared for Board Meeting held on May 21, 2024

Type	Num	Date	Name	Memo	Paid Amount
				Funds Transfer 457(b) Roth	2,995.69
					2,995.69
ACH Payment	FY24M1070	04/20/2024	Paychex	Acct # Y4807254	
Bill	5143368	04/05/2024		Time & Attendance Apr 2024	377.33
					377.33
ACH Payment	1002626598	04/23/2024	CalPERS-Fiscal Services Division	Tier 1 Misc Retirement Plan	
Bill	100000017521905	04/22/2024		Unfunded liability for Tier 1 Misc. Retirement Plan - projected 6/30/2024	1,390,844.00
					1,390,844.00
ACH Payment	1002626599	04/23/2024	CalPERS-Fiscal Services Division	PEPRA Misc. Retirement Plan	
Bill	100000017521907	04/22/2024		Unfunded liability for PEPRA Misc. Retirement Plan - projected 6/30/2024	65,501.00
					65,501.00
ACH Payment	1002626600	04/23/2024	CalPERS-Fiscal Services Division	Tier 2 Misc. Retirement Plan	
Bill	100000017521906	04/22/2024		Unfunded liability for Tier 2 Misc. Retirement Plan - projected 6/30/2024	32,406.00
					32,406.00
ACH Payment	FY24M1068	04/25/2024	WEX Health Inc	Customer ID 45927	
Bill	0001931168-IN	03/31/2024		Monthly HRA Admin Fee March - 2024	30.00
				Monthly HRA Admin Fee March - 2024	54.00
					84.00
ACH Payment	1002629359	05/01/2024	CalPERS - Health Benefits	6882866561	
Bill	17517528	05/01/2024		2024_05	9,527.02
				2024_05	25,747.84
				2024_05	14,927.56
				2024_05	5,997.76
				2024_05	3,000.44
				2024_05	6,708.16
				2024_05	7,263.73
				2024_05	448.15
					73,620.66
ACH Payment	1002629360	05/01/2024	CalPERS - Health Benefits	6882866561	
Bill	17517530	05/01/2024		2024_05	7,035.87
					7,035.87
ACH Payment		05/01/2024		Funds Transfer 457(b) Salary Reduction	
				Funds Transfer 457(b) Salary Reduction	4,156.94
					4,156.94
ACH Payment		05/01/2024		Funds Transfer 457(b) Roth	
				Funds Transfer 457(b) Roth	2,989.92
					2,989.92
ACH Payment	474-148153-	05/01/2024	US Bank Corporate Payment System	Acct # 4246 0445 5568 5498	
Bill	42460445556854980424	04/22/2024		CAL-Card Expenses Apr-2024	17,855.56
					17,855.56
ACH Payment		05/03/2024		Funds Transfer 457(b) OBRA-PST	
				Funds Transfer 457(b) OBRA-PST	846.00
					846.00
ACH Payment	1002631994	05/03/2024	CalPERS-Retirement	17483023	
Bill	4/15/24 - 4/28/24	05/03/2024		Earned Period 04/15/24 - 04/28/24	1,857.81
				Earned Period 04/15/24 - 04/28/24	3,083.13
				Earned Period 04/15/24 - 04/28/24	3,563.80
				Earned Period 04/15/24 - 04/28/24	1,359.28
					9,864.02
ACH Payment	1002631995	05/03/2024	CalPERS-Retirement	17483080	
Bill	4/15/24 - 4/28/24	05/03/2024		Earned Period 04/15/24 - 04/28/24	1,603.13
				Earned Period 04/15/24 - 04/28/24	2,658.31
				Earned Period 04/15/24 - 04/28/24	3,075.24
				Earned Period 04/15/24 - 04/28/24	1,172.93
					8,509.61
ACH Payment	1002631996	05/03/2024	CalPERS-Retirement	17483054	

Midway City Sanitary District

Accounts Payable Expenditures, Payments, Payroll, and ACH Payment(s) Report

Prepared for Board Meeting held on May 21, 2024

Type	Num	Date	Name	Memo	Paid Amount
Bill	4/15/24 - 4/28/24	05/03/2024		Earned Period 04/15/24 - 04/28/24	132.06
				Earned Period 04/15/24 - 04/28/24	219.17
				Earned Period 04/15/24 - 04/28/24	253.34
				Earned Period 04/15/24 - 04/28/24	96.63
					701.20
ACH Payment	1312709	05/10/2024	SoCalGas	Acct # 021-760-4610 6	
Bill	02176046106 0424	04/30/2024		CNG Station Apr-2024 (11,073)	7,905.50
					7,905.50
ACH Payment	90280510202	05/10/2024	Chevron Texaco (Wex Bank)	Acct # 0496-00-525172-3	
Bill	96931441	04/30/2024		Apr-2024	343.01
				Apr-2024	83.04
				Apr-2024	179.79
				Apr-2024	767.09
					1,372.93
ACH Payments Total					\$1,650,812.97
Payroll		04/17/2024		Employee Payroll	93,070.46
Payroll		05/01/2024		Employee Payroll	95,241.17
Payroll		05/03/2024		Board Payroll	8,512.33
Payroll Total					\$196,823.96
Total Disbursements					\$3,395,407.45

Midway City Sanitary District

Accounts Payable Expenditures, Payments, Payroll, and ACH Payment(s) Report

Prepared for Board Meeting held on May 21, 2024

Type	Num	Date	Name	Memo	Paid Amount
Transfers					
Transfer		04/11/2024		Funds Transfer - Initial Deposit to CA Class	
				Funds Transfer - Initial Deposit to CA Class	1,000,000.00
					1,000,000.00
Transfer		04/19/2024		Funds Transfer MM to CHK	
				Funds Transfer MM to CHK	2,500,000.00
					2,500,000.00
Transfer		04/19/2024		Funds Transfer US Bank to CA CLASS	
				Funds Transfer US Bank to CA CLASS	1,000,000.00
					1,000,000.00
Transfer		04/22/2024		Funds Transfer MM to CHK	
				Funds Transfer MM to CHK	250,000.00
					250,000.00
Transfer		04/26/2024		Funds Transfer from MM to CHK	
				Funds Transfer from MM to CHK	125,000.00
					125,000.00
Transfer		05/01/2024		Funds Transfer from MM to CHK	
				Funds Transfer from MM to CHK	500,000.00
					500,000.00
Transfer		05/10/2024		Funds Transfer LAIF to US Bank CHK	
				Funds Transfer LAIF to US Bank CHK	500,000.00
					500,000.00
Transfers Total					\$5,875,000.00

AGENDA ITEM #6B

Date: May 21, 2024

To: Board of Directors

From: Robert Housley, General Manager

Prepared by: Robert Housley, General Manager

Subject: Approve and File the Treasurer’s Investment Report for April 2024

BACKGROUND

Midway City Sanitary District’s investment policy requires a monthly investment report, which includes all financial investments of the district and provides information on the investment type, value, and yield available for all investments. The report also provides the Board of Directors with an update on the balances of the District’s various funds.

Per the State Government Code 53600 et seq., and the Midway City Sanitary District’s (District) Investment Policy, the District may invest up to a maximum percentage of the entire portfolio funds in authorized financial investments.

The following table shows a summary of the District’s authorized financial investments, the yield available as of the preparation of this report, the book and market value of the District’s funds, the percentage of the District’s pooled funds that are invested in each financial investment, and the maximum percentage (or dollar limit), allowable per the State Government Code and the District’s investment policy.

MCSD’s total invested cash as of April 30, 2024, is \$55,119,649.32

	TYPE OF INVESTMENT	MATURITY DATE	YIELD	BOOK VALUE AS OF 4/30/2024	MARKET VALUE AS OF 4/30/2024	% OF PORTFOLIO	MAXIMUM PERCENTAGE OF PORTFOLIO
FDIC Insured Accounts							
US Bank Interest Checking	Checking	Liquid	0.051%	\$ 824,562.03	\$ 824,562.03	1.50%	None
US Bank Money Market	Money Market	Liquid	0.051%	\$ 48,830.01	\$ 48,830.01	0.09%	20%
Certificate of Deposits	CD	-		\$ -	\$ -	0.00%	30%
Total FDIC Insured Accounts				\$ 873,392.04	\$ 873,392.04	1.59%	
LAIF							
California CLASS (Prime Fund)	Pool	Liquid	4.272%	\$ 50,796,600.19	\$ 50,796,600.19	92.16%	\$75 million
CalTRUST (Medium Term Fund)	Pool/Bond Fund	Liquid	-0.460%	\$ 1,532,350.47	\$ 1,445,381.45	2.62%	30%
U.S. Treasury Securities	US Securities	-	-	\$ -	\$ -	0.00%	None
TOTAL Investments				\$ 55,206,618.34	\$ 55,119,649.32	100.00%	

FISCAL IMPACT

There is no fiscal impact associated with the approval of this informational report.

STAFF RECOMMENDATION

Staff recommends that the Board of Directors approve and file the Treasurer's Investment Report.

ATTACHMENTS:

1. Treasurer's Investment Report

MIDWAY CITY SANITARY DISTRICT
District Investment Activities
4/30/2024

	Operating Fund 1040.10	Midway City 1040.20	Buildings Equipment & Facilities 1040.30	Lift Stations & Sewer Lines 1040.40	CNG Station & Fueling Facilities 1040.50	Vehicle Replacement 1040.60	Total LAIF Account No. 7030-005	CA CLASS Prime Fund #1050.00	CalTRUST Medium-Term #114.00
Beginning Balance, 04.01.2024	\$ 10,160,678.20	\$ 1,915,162.56	\$ 3,358,918.86	\$ 30,624,647.07	\$ 2,001,632.08	\$ 3,193,881.51	\$ 51,254,920.28	\$ -	\$ 1,457,326.75
Investment Income (LAIF, CalTRUST, CA CLASS)	\$ 107,381.61	\$ 20,240.11	\$ 35,498.23	\$ 323,651.97	\$ 21,153.95	\$ 33,754.06	\$ 541,679.93	\$ 4,275.64	\$ 5,220.49
Market Value Capital Gain/(Loss)									\$ (11,945.30)
Transfer from LAIF to US Bank	\$ (1,000,000.00)								
Transfer from US Bank to LAIF									
Transfers LAIF to LAIF	\$ 449,339.20					\$ (449,339.20)			
Transfers US Bank to California CLASS								\$ 2,000,000.00	
Transfers California CLASS to US Bank									
Transfer CalTRUST to/from US Bank									
Ending Balance, 04.30.2024	\$ 9,717,399.01	\$ 1,935,402.67	\$ 3,394,417.09	\$ 30,948,299.04	\$ 2,022,786.03	\$ 2,778,296.37	\$ 50,796,600.21	\$ 2,004,275.64	\$ (5,220.49)

TOTAL LAIF, U.S. SECURITIES, CA CLASS, CalTRUST
& INTEREST RECEIVABLE
ADD: US BANK
a. Checking (158301509028) \$ 824,562.03
b. Money Market (158200156913) \$ 48,830.01
TOTAL DISTRICT CASH ON HAND \$ 53,115,373.70

C E R T I F I C A T I O N
I certify that (1) all investment actions executed since the last report have been made in full compliance with the District's Investment Policy and, (2) the District will meet its expenditure obligations for the next six months as required by California Government Code Sections 53646(b)(2) and (3), respectively.

Prepared & Submitted by _____
Robert Housley, General Manager

Dated 5/13/2024
Sergio Contreras, Board Treasurer

MCSD Portfolio as of 04.30.2024

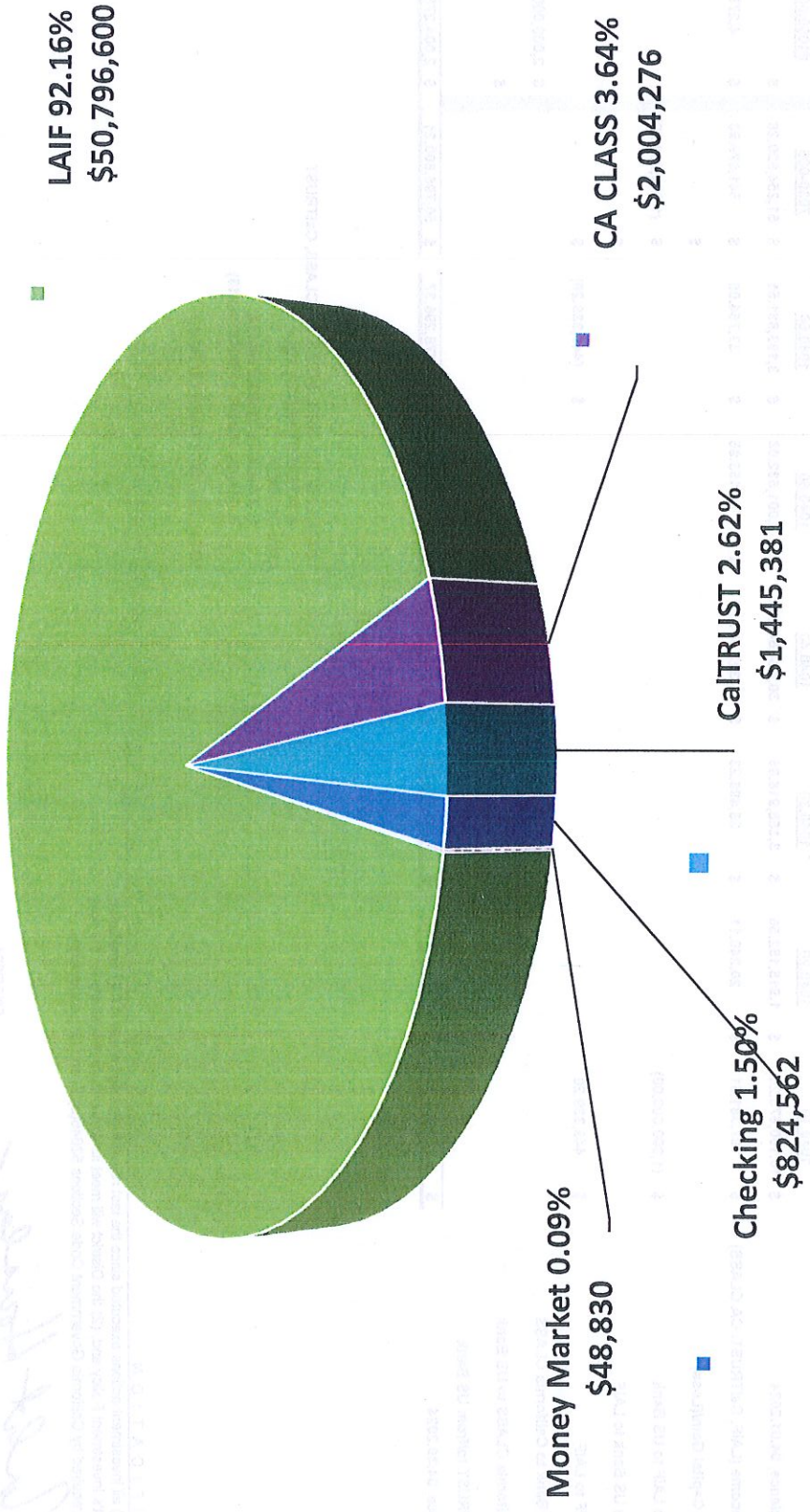

Just Hand



California State Treasurer
Fiona Ma, CPA



Home | Open Government | Careers | Contact | Calendar

Search



Home PMIA Home Contacts Time Deposits LAIF

Home >> PMIA >> PMIA Average Monthly Effective Yields



LOCAL AGENCY INVESTMENT FUND

PMIA Average Monthly Effective Yields

	Jan	Feb	Mar	Apr	May	Jun	Jul	Aug	Sep	Oct	Nov	Dec
1977	5.770	5.660	5.660	5.650	5.760	5.850	5.930	6.050	6.090	6.090	6.610	6.730
1978	6.920	7.050	7.140	7.270	7.386	7.569	7.652	7.821	7.871	8.110	8.286	8.769
1979	8.777	8.904	8.820	9.082	9.046	9.224	9.202	9.528	9.259	9.814	10.223	10.218
1980	10.980	11.251	11.490	11.480	12.017	11.798	10.206	9.870	9.945	10.056	10.426	10.961
1981	10.987	11.686	11.130	11.475	12.179	11.442	12.346	12.844	12.059	12.397	11.887	11.484
1982	11.683	12.044	11.835	11.773	12.270	11.994	12.235	11.909	11.151	11.111	10.704	10.401
1983	10.251	9.887	9.688	9.868	9.527	9.600	9.879	10.076	10.202	10.182	10.164	10.227
1984	10.312	10.280	10.382	10.594	10.843	11.119	11.355	11.557	11.597	11.681	11.474	11.024
1985	10.579	10.289	10.118	10.025	10.180	9.743	9.656	9.417	9.572	9.482	9.488	9.371
1986	9.252	9.090	8.958	8.621	8.369	8.225	8.141	7.844	7.512	7.586	7.432	7.439
1987	7.365	7.157	7.205	7.044	7.294	7.289	7.464	7.562	7.712	7.825	8.121	8.071
1988	8.078	8.050	7.945	7.940	7.815	7.929	8.089	8.245	8.341	8.397	8.467	8.563
1989	8.698	8.770	8.870	8.992	9.227	9.204	9.056	8.833	8.801	8.771	8.685	8.645
1990	8.571	8.538	8.506	8.497	8.531	8.538	8.517	8.382	8.333	8.321	8.269	8.279
1991	8.164	8.002	7.775	7.666	7.374	7.169	7.098	7.072	6.859	6.719	6.591	6.318
1992	6.122	5.863	5.680	5.692	5.379	5.323	5.235	4.958	4.760	4.730	4.659	4.647
1993	4.678	4.649	4.624	4.605	4.427	4.554	4.438	4.472	4.430	4.380	4.365	4.384
1994	4.359	4.176	4.248	4.333	4.434	4.623	4.823	4.989	5.106	5.243	5.380	5.528
1995	5.612	5.779	5.934	5.960	6.008	5.997	5.972	5.910	5.832	5.784	5.805	5.748
1996	5.698	5.643	5.557	5.538	5.502	5.548	5.587	5.566	5.601	5.601	5.599	5.574
1997	5.583	5.575	5.580	5.612	5.634	5.667	5.679	5.690	5.707	5.705	5.715	5.744
1998	5.742	5.720	5.680	5.672	5.673	5.671	5.652	5.652	5.639	5.557	5.492	5.374
1999	5.265	5.210	5.136	5.119	5.086	5.095	5.178	5.225	5.274	5.391	5.484	5.639
2000	5.760	5.824	5.851	6.014	6.190	6.349	6.443	6.505	6.502	6.517	6.538	6.535
2001	6.372	6.169	5.976	5.760	5.328	4.958	4.635	4.502	4.288	3.785	3.526	3.261
2002	3.068	2.967	2.861	2.845	2.740	2.687	2.714	2.594	2.604	2.487	2.301	2.201
2003	2.103	1.945	1.904	1.858	1.769	1.697	1.653	1.632	1.635	1.596	1.572	1.545
2004	1.528	1.440	1.474	1.445	1.426	1.469	1.604	1.672	1.771	1.890	2.003	2.134
2005	2.264	2.368	2.542	2.724	2.856	2.967	3.083	3.179	3.324	3.458	3.636	3.808
2006	3.955	4.043	4.142	4.305	4.563	4.700	4.849	4.946	5.023	5.098	5.125	5.129
2007	5.156	5.181	5.214	5.222	5.248	5.250	5.255	5.253	5.231	5.137	4.962	4.801
2008	4.620	4.161	3.777	3.400	3.072	2.894	2.787	2.779	2.774	2.709	2.568	2.353
2009	2.046	1.869	1.822	1.607	1.530	1.377	1.035	0.925	0.750	0.646	0.611	0.569
2010	0.558	0.577	0.547	0.588	0.560	0.528	0.531	0.513	0.500	0.480	0.454	0.462
2011	0.538	0.512	0.500	0.588	0.413	0.448	0.381	0.408	0.378	0.385	0.401	0.382
2012	0.385	0.389	0.383	0.367	0.363	0.358	0.363	0.377	0.348	0.340	0.324	0.326
2013	0.300	0.286	0.285	0.264	0.245	0.244	0.267	0.271	0.257	0.266	0.263	0.264
2014	0.244	0.236	0.236	0.233	0.228	0.228	0.244	0.260	0.246	0.261	0.261	0.267
2015	0.262	0.266	0.278	0.283	0.290	0.299	0.320	0.330	0.337	0.357	0.374	0.400
2016	0.446	0.467	0.506	0.525	0.552	0.576	0.588	0.614	0.634	0.654	0.678	0.719
2017	0.751	0.777	0.821	0.884	0.925	0.978	1.051	1.084	1.111	1.143	1.172	1.239
2018	1.350	1.412	1.524	1.661	1.755	1.854	1.944	1.998	2.063	2.144	2.208	2.291
2019	2.355	2.392	2.436	2.445	2.449	2.428	2.379	2.341	2.280	2.190	2.103	2.043
2020	1.967	1.912	1.787	1.648	1.363	1.217	0.920	0.784	0.685	0.620	0.576	0.540
2021	0.458	0.407	0.357	0.339	0.315	0.262	0.221	0.221	0.206	0.203	0.203	0.212
2022	0.234	0.278	0.365	0.523	0.684	0.861	1.090	1.276	1.513	1.772	2.007	2.173
2023	2.425	2.624	2.831	2.870	2.993	3.167	3.305*	3.434	3.534	3.670	3.843	3.929
2024	4.012	4.122	4.232	4.272								

LAIF STATISTICS AS OF 04/30/24

	Balance By Type	Participation	% of Fund
54 COUNTIES	1,003,394,843.01	2.30%	4.65%
475 CITIES	10,273,632,457.18	20.25%	47.59%
1,438 SPECIAL DISTRICTS	9,036,400,125.44	61.30%	41.86%
191 SCHOOL DISTRICTS	594,265,368.08	8.14%	2.75%
146 TRUSTEES	574,523,303.30	6.22%	2.66%
42 BONDS	103,580,905.86	1.79%	0.48%
2,346 Fund Balance:	\$21,585,797,002.87	100.00%	100.00%

Participation:

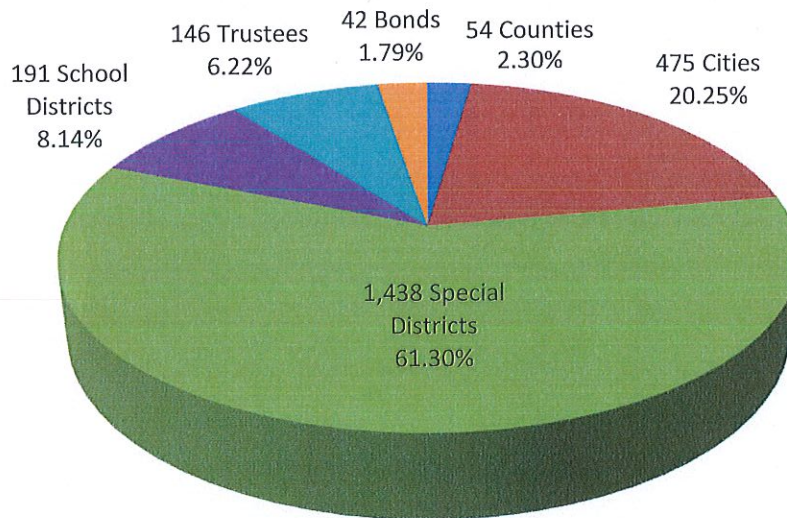

Balance by Type (dollars in millions):

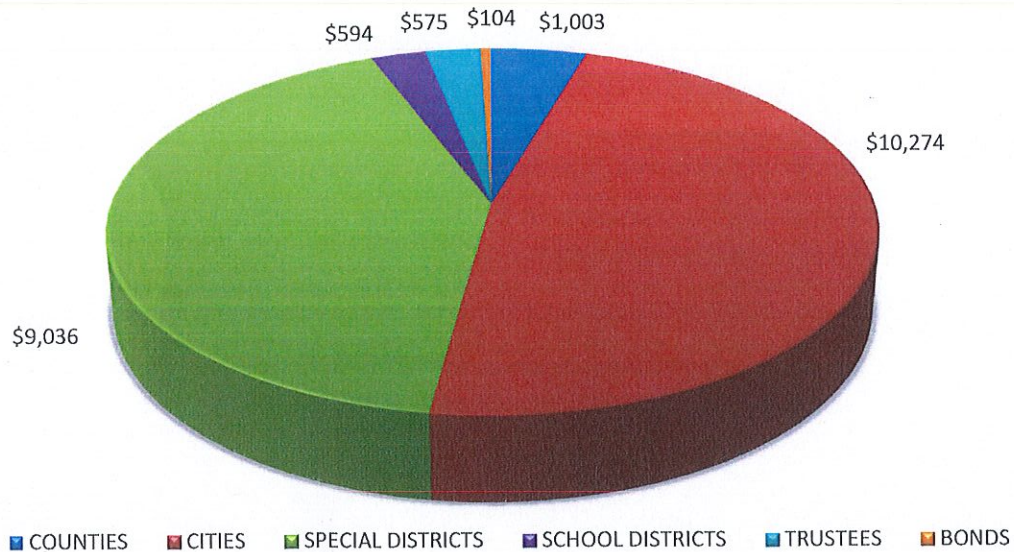

Percentages may not total 100% due to rounding.



0000147-0000577 PDF 645113

Midway City Sanitary District
14451 Cedarwood Street
Westminster, CA 92708

Summary Statement

April 30, 2024

Page 1 of 3

Investor ID: CA-01-0164

California CLASS

California CLASS

Average Monthly Yield: 5.4028%

	Beginning Balance	Contributions	Withdrawals	Income Earned	Income Earned YTD	Average Daily Balance	Month End Balance
CA-01-0164-0001 Operating Funds	0.00	2,000,000.00	0.00	4,275.64	4,275.64	1,100,142.52	2,004,275.64
TOTAL	0.00	2,000,000.00	0.00	4,275.64	4,275.64	1,100,142.52	2,004,275.64

Tel: (877) 930-5213

www.californiaclass.com

Account Number: CA-01-0164-0001

Operating Funds

Account Summary

Average Monthly Yield: 5.4028%

Transaction Date	Transaction Description	Beginning Balance	Contributions	Withdrawals	Income Earned YTD	Average Daily Balance	Month End Balance	Transaction Number
04/10/2024	Contribution	0.00	2,000,000.00	0.00	4,275.64	1,100,142.52	2,004,275.64	4101
04/19/2024	Contribution		1,000,000.00					4153
04/30/2024	Income Dividend Reinvestment		4,275.64					
04/30/2024	Ending Balance						2,004,275.64	

Transaction Activity

Transaction Date	Transaction Description	Contributions	Withdrawals	Balance	Transaction Number
04/10/2024	Contribution	1,000,000.00			4101
04/19/2024	Contribution	1,000,000.00			4153
04/30/2024	Income Dividend Reinvestment	4,275.64			
04/30/2024	Ending Balance			2,004,275.64	





California CLASS

California CLASS

Date	Dividend Rate	Daily Yield
04/01/2024	0.000147976	5.4159%
04/02/2024	0.000148276	5.4269%
04/03/2024	0.000148007	5.4170%
04/04/2024	0.000147868	5.4120%
04/05/2024	0.000443427	5.4098%
04/06/2024	0.000000000	5.4098%
04/07/2024	0.000000000	5.4098%
04/08/2024	0.000147874	5.4122%
04/09/2024	0.000147704	5.4060%
04/10/2024	0.000147791	5.4092%
04/11/2024	0.000147788	5.4091%
04/12/2024	0.000443118	5.4060%
04/13/2024	0.000000000	5.4060%
04/14/2024	0.000000000	5.4060%
04/15/2024	0.000147746	5.4075%
04/16/2024	0.000147898	5.4131%
04/17/2024	0.000147779	5.4087%
04/18/2024	0.000147538	5.3999%
04/19/2024	0.000441714	5.3889%
04/20/2024	0.000000000	5.3889%
04/21/2024	0.000000000	5.3889%
04/22/2024	0.000147161	5.3861%
04/23/2024	0.000146940	5.3780%
04/24/2024	0.000147365	5.3936%
04/25/2024	0.000147775	5.4086%
04/26/2024	0.000443496	5.4107%
04/27/2024	0.000000000	5.4107%
04/28/2024	0.000000000	5.4107%
04/29/2024	0.000147940	5.4146%
04/30/2024	0.000145352	5.3199%

Performance results are shown net of all fees and expenses and reflect the reinvestment of dividends and other earnings. Many factors affect performance including changes in market conditions and interest rates and in response to other economic, political, or financial developments. Investment involves risk including the possible loss of principal. No assurance can be given that the performance objectives of a given strategy will be achieved. **Past performance is no guarantee of future results. Any financial and/or investment decision may incur losses.**

Fund Info Detail

CACCLASS

As Of Date: 04/30/2024

NAV

\$1.00

Shares:	1,330,923,202.650
Fund Balance:	\$1,330,860,103.58
Dividend Rate:	0.000145352317
Current Yield:	N/A
Daily Yield:	5.3199%
7-Day Yield:	5.3955%
30-Day Yield:	5.4028%

CLOSE

Historical Fund Info - California CLASS Portal

As Of Date	Fund Name	NAV	Shares	Fund Balance	Dividend Rate	Current Yield	Daily Yield	7-Day Yield	30-Day Yield	Yield Details
04/30/2024	CACLASS	\$1.00	1,330,923,202.650	\$1,330,860,103.58	0.000145352317	N/A	5.3199%	5.3955%	5.4028%	View
04/30/2024	CA Enhanced Cash	\$10.00	2,062,426.703	\$20,624,267.03	0.001479878381	5.4164%	N/A	N/A	N/A	View

As Of Date: 04/30/2024

30-Day Yield:
7-Day Yield:
Daily Yield:
Current Yield:
Dividend Rate:
Fund Balance:

NAV

Shares



CalTRUST
 PO Box 2709
 Granite Bay, CA 95746
 www.caltrust.org
 Email: admin@caltrust.org
 Fax: 402-963-9094
 Phone: 833-CALTRUST (225-8787)

Investment Account Summary

04/01/2024 through 04/30/2024

SUMMARY OF INVESTMENTS

Fund	Account Number	Total Shares Owned	Net Asset Value per Share on Apr 30 (\$)	Value on Apr 30 (\$)	Average Cost Amount (\$)	Cumulative Change in Value (\$)
MIDWAY CITY SANITARY DISTRICT	20100007910					
CalTRUST Medium Term Fund	20100007910	149,316.265	9.68	1,445,381.45	1,532,350.47	(86,969.02)
Portfolios Total value as of 04/30/2024				1,445,381.45		

DETAIL OF TRANSACTION ACTIVITY

Activity Description	Activity Date	Amount (\$)	Amount in Shares	Balance in Shares	Price per Share (\$)	Balance (\$)	Average Cost Amt (\$)	Realized Gain/(Loss) (\$)
CalTRUST Medium Term Fund		MIDWAY CITY SANITARY DISTRICT Account Number: 20100007910						
Beginning Balance	04/01/2024			149,316.265	9.76	1,457,326.75		
Accrual Income Div Cash	04/30/2024	5,220.49	0.000	149,316.265	9.68	1,445,381.45	0.00	0.00
Change in Value						(11,945.30)		
Closing Balance as of	Apr 30			149,316.265	9.68	1,445,381.45		



2024 CalTRUST Closures

Please note that the CalTRUST Funds will be closed for trading on the following days:

Date	Holiday
January 1, 2024	New Year's Day
January 15, 2024	Martin Luther King, Jr. Day
February 19, 2024	Presidents' Day
March 29, 2024	Good Friday
May 27, 2024	Memorial Day
June 19, 2024	Juneteenth National Independence Day
July 4, 2024	Independence Day
September 2, 2024	Labor Day
October 14, 2024	Indigenous Peoples Day
November 11, 2024	Veterans Day
November 28, 2024	Thanksgiving Day
December 25, 2024	Christmas Day

EARLY CLOSURES:

March 28, May 24, July 3, November 29, December 24, and December 31



	CaITRUST Medium Term	BofAML 1-3 Corp & Gov't, A Rated and Above	CaITRUST Medium Term Net Total Return	CaITRUST Medium Term Yield	BofAML 1-3 Corp & Gov't, A Rated and Above
Net Assets	\$989,377,571.78	N/A	-0.46%	0.33%	-0.29%
NAV per Share	\$9.68	N/A	-0.46%	0.98%	-0.25%
30 Day SEC Yield	4.84%	N/A	2.49%	1.96%	2.51%
Distribution Yield	4.01%	N/A	2.67%	3.82%	2.94%
Period Net Total Return	-0.46%	-0.29%	2.00%	2.98%	2.04%
Effective Duration	2.08 yrs	N/A	0.17%	2.13%	0.14%
Average Maturity	2.33 yrs	N/A	1.22%	1.88%	1.27%
Weighted Average Life	2.29 yrs	N/A	1.16%	1.58%	1.26%
			1.83%	1.99%	2.12%

	One Month	Three Month	Six Month	One Year*	Two Year*	Three Year*	Five Year*	Ten Year*	Since Inception*
CaITRUST Medium Term Net Total Return	-0.46%	-0.46%	2.49%	2.67%	2.00%	0.17%	1.22%	1.16%	1.83%

*Annualized

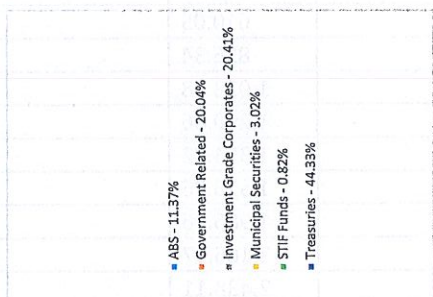

Rated AA-f by S&P Global Ratings

**Midway City Sanitary District
CalTRUST Summary**

CalTRUST - Medium-Term Fund

	Investment + '+'	Dividends '+'	Distribution of Dividend (-)	Capital Gain or Loss (-)	Balance
Investment May-2020	\$ 750,000.00	432.90		1,460.57	\$ 751,893.47
June-2020		857.56		730.70	\$ 753,481.73
July-2020		765.26		731.54	\$ 754,978.53
August-2020		745.40		-	\$ 755,723.93
September-2020		677.57		(733.01)	\$ 755,668.49
October-2020		621.72		(733.66)	\$ 755,556.55
November-2020		476.58		-	\$ 756,033.13
December-2020		439.21			\$ 756,472.34
January-2021		387.68			\$ 756,860.02
February-2021		342.73		(1,471.06)	\$ 755,731.69
March-2021		354.98		(735.87)	\$ 755,350.80
April-2021		251.06			\$ 755,601.86
May-2021	\$ 750,000.00	316.74		736.45	\$ 1,506,655.05
June-2021		473.98		(1,467.04)	\$ 1,505,661.99
July-2021		415.67		1,467.51	\$ 1,507,545.17
August-2021		390.03		0.01	\$ 1,507,935.21
September-2021		370.72		(1,468.29)	\$ 1,506,837.64
October-2021		396.41		(5,874.61)	\$ 1,501,359.44
November-2021		461.36		(1,469.04)	\$ 1,500,351.76
December-2021		516.64		(2,938.98)	\$ 1,497,929.42
January-2022		598.08		(10,289.99)	\$ 1,488,237.51
February-2022		610.05		(7,352.96)	\$ 1,481,494.60
March-2022		836.34		(20,596.74)	\$ 1,461,734.20
April-2022		1,028.38		(8,832.23)	\$ 1,453,930.35
May-2022		1,290.86		5,892.32	\$ 1,461,113.53
June-2022		1,354.72		(8,846.29)	\$ 1,453,621.96
July-2022		1,518.86		5,903.03	\$ 1,461,043.85
August-2022		1,986.06		(11,818.35)	\$ 1,451,211.56
September-2022		2,166.97		(20,710.46)	\$ 1,432,668.07
October-2022		2,438.11		(4,444.68)	\$ 1,430,661.50
November-2022		2,709.46		8,904.53	\$ 1,442,275.49
December-2022		2,890.90		1,486.88	\$ 1,446,653.27
January-2023		3,227.48		8,939.16	\$ 1,458,819.91
February-2023		3,447.06	(3,447.06)	(13,438.46)	\$ 1,445,381.45
March-2023		4,147.17	(4,147.17)	14,931.62	\$ 1,460,313.07
April-2023		3,791.32	(3,791.32)	1,493.16	\$ 1,461,806.23
May-2023		4,482.39	(4,482.39)	(7,465.81)	\$ 1,454,340.42
June-2023		4,090.56	(4,090.56)	(8,958.97)	\$ 1,445,381.45
July-2023		4,246.18	(4,246.18)	1,493.16	\$ 1,446,874.61
August-2023		4,455.68	(4,455.68)	-	\$ 1,446,874.61
September-2023		4,286.72	(4,286.72)	(7,465.82)	\$ 1,439,408.79
October-2023		4,795.72	(4,795.72)	(1,493.16)	\$ 1,437,915.63
November-2023		4,603.47	(4,603.47)	14,931.63	\$ 1,452,847.26
December-2023		4,484.90	(4,484.90)	13,438.46	\$ 1,466,285.72
January-2024		5,122.63	(5,122.63)	-	\$ 1,466,285.72
February-2024		4,548.47	(4,548.47)	(10,452.14)	\$ 1,455,833.58
March-2024		4,411.96	(4,411.96)	1,493.17	\$ 1,457,326.75
April-2024		5,220.49	(5,220.49)	(11,945.30)	\$ 1,445,381.45
\$ 1,500,000.00 \$ 98,485.19 \$ (66,134.72) \$ (86,969.02)					

AGENDA ITEM #6C

Date: May 21, 2024

To: Board of Directors

From: Robert Housley, General Manager

Prepared by: Robert Housley, General Manager

Subject: Receive and File the 3rd Quarter 2023-2024 Fiscal Year Financial and Budget Reports

BACKGROUND

Quarterly, the Midway City Sanitary District legislative body reviews its financial and budget reports. The reports were prepared by the Finance Department and reviewed by the General Manager and Department Heads.

DISCUSSION

The 3rd quarter financial and budget reports are in line with approved budgeted items and in accordance with District policies and procedures.

FISCAL IMPACT

Informational report only. No fiscal impact.

STAFF RECOMMENDATION

Staff recommends that the Board of Directors receive and file the 3rd Quarter financial and budget reports.

ATTACHMENTS:

1. Statement of Net Assets [yellow]
2. Statement of Revenue Expenses and Changes in Net Position [green]
3. Budget vs. Actual [purple]

Midway City Sanitary District
Statement of Net Assets
As of March 31, 2024

	Mar 31, 24	Mar 31, 23	\$ Change
ASSETS			
Current Assets			
Checking/Savings			
1000.00 · Cash in Checking - US 9028	1,602,971.88	182,077.65	1,420,894.23
1020.00 · Money Market - US 6913	97,779.71	352.41	97,427.30
1030.00 · Petty Cash	300.00	300.00	0.00
1035.00 · HRA Reserve Fund - WEX	15,062.66	7,880.53	7,182.13
1037.00 · Escrow Account - CBB 4618	0.00	74,757.39	-74,757.39
1040.00 · Local Agency Investment Fund			
1040.10 · Operating	10,160,678.20	8,580,029.16	1,580,649.04
1040.20 · Midway City	1,915,162.56	1,612,905.53	302,257.03
1040.30 · Buildings, Equip & Facilities	3,358,918.86	5,296,131.67	-1,937,212.81
1040.40 · Lift Stations & Sewer Lines	30,624,647.07	30,606,387.01	18,260.06
1040.50 · CNG Station & Facilities	2,001,632.08	1,934,609.34	67,022.74
1040.60 · Vehicle Replacement	3,193,881.51	4,004,451.95	-810,570.44
Total 1040.00 · Local Agency Investment Fund	51,254,920.28	52,034,514.66	-779,594.38
1070.00 · CalTRUST			
1070.10 · CalTRUST Medium-Term Fund	1,532,350.48	1,532,350.48	0.00
1070.20 · CalTRUST Market Gain/(Loss)	-75,023.73	-72,037.41	-2,986.32
Total 1070.00 · CalTRUST	1,457,326.75	1,460,313.07	-2,986.32
1090.00 · 115 Trust Fund, Restricted			
1090.10 · CEPPT Trust Related to Pensions	4,575,000.00	4,325,000.00	250,000.00
1090.20 · CEPPT Trust Market Gain/(Loss)	734,539.63	266,295.83	468,243.80
Total 1090.00 · 115 Trust Fund, Restricted	5,309,539.63	4,591,295.83	718,243.80
Total Checking/Savings	59,737,900.91	58,351,491.54	1,386,409.37
Other Current Assets			
2005.00 · Accrued Receivables	114,052.81	0.00	114,052.81
2015.00 · Interest Receivable	546,091.87	359,474.39	186,617.48
2600.00 · Inventory			
2600.20 · Pump Inventory	329,195.65	0.00	329,195.65
2600.10 · Parts Inventory	135,266.15	164,878.66	-29,612.51
Total 2600.00 · Inventory	464,461.80	164,878.66	299,583.14
Total Other Current Assets	1,124,606.48	524,353.05	600,253.43
Total Current Assets	60,862,507.39	58,875,844.59	1,986,662.80
Fixed Assets			
3500.00 · Land	92,948.00	92,948.00	0.00
3510.00 · Construction Work In Progress			
3510.01 · WIP Office Furniture	2,341.24	0.00	2,341.24
3500.03 · WIP Technology	29,523.91	0.00	29,523.91
3500.04 · WIP Solor Project	536,098.37	0.00	536,098.37
3510.00 · Construction Work In Progress - Other	6,370,113.00	1,893,229.82	4,476,883.18
Total 3510.00 · Construction Work In Progress	6,938,076.52	1,893,229.82	5,044,846.70

Midway City Sanitary District
Statement of Net Assets
As of March 31, 2024

	<u>Mar 31, 24</u>	<u>Mar 31, 23</u>	<u>\$ Change</u>
3520.00 · Buildings & Improvements	906,409.40	906,409.40	0.00
3530.00 · Lift Stations	5,582,673.12	5,582,673.12	0.00
3540.00 · Gravity Lines & Force Mains	17,818,984.25	17,818,984.25	0.00
3550.00 · Resident Containers	857,689.02	857,689.02	0.00
3560.00 · CNG Station & Facilities	3,459,268.18	3,459,268.18	0.00
3570.00 · Solid Waste Trash Trucks	6,377,415.26	5,019,135.23	1,358,280.03
3580.00 · Other Vehicles			
3580.10 · Administration Vehicles	63,387.30	63,387.30	0.00
3580.20 · Solid Waste Vehicles	167,559.58	165,249.21	2,310.37
3580.30 · Sewer Trucks & Vehicles	1,253,860.45	1,223,647.19	30,213.26
Total 3580.00 · Other Vehicles	<u>1,484,807.33</u>	<u>1,452,283.70</u>	<u>32,523.63</u>
3590.00 · Other Equipment			
3590.10 · Office Furniture & Equipment	189,157.71	64,770.46	124,387.25
3590.20 · Garage Facilities	88,726.39	88,726.39	0.00
3590.30 · Garage Equipment & Vehicles	161,985.14	161,985.14	0.00
3590.40 · Solid Waste Equipment - Other	58,325.84	58,325.84	0.00
3590.50 · Sewer Equipment - Other	693,089.46	685,214.46	7,875.00
Total 3590.00 · Other Equipment	<u>1,191,284.54</u>	<u>1,059,022.29</u>	<u>132,262.25</u>
3600.00 · Accumulated Depreciation			
3600.10 · Accumulated Depreciation Admin	-2,035,746.48	-2,057,468.20	21,721.72
3600.20 · Accumulated Depreciation Garage	-12,847.20	-11,126.74	-1,720.46
3600.30 · Accum Depreciation Solid Waste	-4,778,846.86	-4,593,088.22	-185,758.64
3600.40 · Accumulated Depreciation Sewer	-9,132,842.77	-8,955,184.10	-177,658.67
Total 3600.00 · Accumulated Depreciation	<u>-15,960,283.31</u>	<u>-15,616,867.26</u>	<u>-343,416.05</u>
Total Fixed Assets	<u>28,749,272.31</u>	<u>22,524,775.75</u>	<u>6,224,496.56</u>
Other Assets			
6500.00 · Deferred Outflows from Pension	2,134,820.00	2,877,433.00	-742,613.00
6510.00 · Deferred Outflows from OPEB	1,879,200.00	220,451.00	1,658,749.00
Total Other Assets	<u>4,014,020.00</u>	<u>3,097,884.00</u>	<u>916,136.00</u>
TOTAL ASSETS	<u><u>93,625,799.70</u></u>	<u><u>84,498,504.34</u></u>	<u><u>9,127,295.36</u></u>
LIABILITIES & EQUITY			
Liabilities			
Current Liabilities			
Accounts Payable			
5000.00 · Accounts Payable	1,834,304.09	293,790.77	1,540,513.32
Total Accounts Payable	<u>1,834,304.09</u>	<u>293,790.77</u>	<u>1,540,513.32</u>
Credit Cards			
5005.00 · US Bank Cal Card	-8,700.19	6,935.92	-15,636.11
Total Credit Cards	<u>-8,700.19</u>	<u>6,935.92</u>	<u>-15,636.11</u>
Other Current Liabilities			
5010.00 · Accrued Expenses			
5010.10 · Payroll	554.00	0.00	554.00

Midway City Sanitary District
Statement of Net Assets
As of March 31, 2024

	<u>Mar 31, 24</u>	<u>Mar 31, 23</u>	<u>\$ Change</u>
5010.30 · OC San CFC Charge	-1,155.79	0.00	-1,155.79
5010.40 · Group Insurance	16.95	16.95	0.00
5010.00 · Accrued Expenses - Other	-552.00	213,152.15	-213,704.15
Total 5010.00 · Accrued Expenses	<u>-1,136.84</u>	<u>213,169.10</u>	<u>-214,305.94</u>
Total Other Current Liabilities	<u>-1,136.84</u>	<u>213,169.10</u>	<u>-214,305.94</u>
Total Current Liabilities	1,824,467.06	513,895.79	1,310,571.27
Long Term Liabilities			
6520.00 · Deferred Inflows from Pension	61,731.00	472,822.00	-411,091.00
6530.00 · Deferred Inflows from OPEB	1,732,662.00	1,755,522.00	-22,860.00
6540.00 · Net Pension Liability	611,954.00	-2,768,839.00	3,380,793.00
6550.00 · Net OPEB Liability	-847,810.40	-2,292,610.40	1,444,800.00
Total Long Term Liabilities	<u>1,558,536.60</u>	<u>-2,833,105.40</u>	<u>4,391,642.00</u>
Total Liabilities	3,383,003.66	-2,319,209.61	5,702,213.27
Equity			
4000.00 · Net Position	85,564,156.99	84,108,867.98	1,455,289.01
4100.00 · Restricted	41,804.02	109,840.71	-68,036.69
Net Income	4,636,835.03	2,599,005.26	2,037,829.77
Total Equity	<u>90,242,796.04</u>	<u>86,817,713.95</u>	<u>3,425,082.09</u>
TOTAL LIABILITIES & EQUITY	<u><u>93,625,799.70</u></u>	<u><u>84,498,504.34</u></u>	<u><u>9,127,295.36</u></u>

Midway City Sanitary District
Statement of Revenues, Expenses and Changes in Net Position
3Q FY 2023-2024

	<u>Jul '23 - Mar 24</u>	<u>Jul '22 - Mar 23</u>	<u>\$ Change</u>
Income			
7000.00 · Operating Revenues			
7010.00 · Trash & Sewer Collection Fees	4,967,338.37	4,795,033.33	172,305.04
7020.00 · Add'l Container & Service Fees	12,291.80	11,178.74	1,113.06
7030.00 · Franchise Fees	1,012,352.35	810,873.81	201,478.54
7040.00 · Plan Check & Inspection Fees	44,247.74	41,054.93	3,192.81
7050.00 · Connection Fees	13,027.88	14,948.65	-1,920.77
Total 7000.00 · Operating Revenues	<u>6,049,258.14</u>	<u>5,673,089.46</u>	<u>376,168.68</u>
8000.00 · Non-Operating Revenues			
8010.00 · Property Tax Secured	813,057.66	818,730.84	-5,673.18
8020.00 · Property Tax Unsecured	34,073.50	32,089.91	1,983.59
8030.00 · Property Tax Supplemental	20,243.35	33,433.30	-13,189.95
8040.00 · Homeowner's Prop Tax Relief	2,650.47	2,882.46	-231.99
8050.00 · Public Utility & Reg. Railroad	32,497.12	32,408.20	88.92
8060.00 · Pass-thru County of Orange	334,439.19	240,565.49	93,873.70
8070.00 · Pass-thru City of Westminster	2,000,598.62	1,878,537.79	122,060.83
8080.00 · Investment Income	2,727,458.91	1,617,232.02	1,110,226.89
8090.00 · Interest on Unapportioned Taxes	8,924.93	1,600.18	7,324.75
8100.00 · Other Revenue			
8100.10 · Mattress Recycling	4,900.50	3,471.75	1,428.75
8100.20 · Scrap Metals & Recycables	7,046.34	6,589.65	456.69
8100.30 · Used Oil Recycling	470.00	216.00	254.00
8100.40 · CalRecycle Curbside Program	0.00	25.56	-25.56
8100.50 · Renewable Fuel RINS/LCFS	9,071.55	7,522.57	1,548.98
8100.60 · Waste Disposal Agreement	0.00	0.00	0.00
8100.70 · Grants & Agreements	0.00	0.00	0.00
8100.75 · Sponsorships	9,500.00	0.00	9,500.00
8100.80 · Miscellaneous Other Revenue	2,435.65	1,223.23	1,212.42
Total 8100.00 · Other Revenue	<u>33,424.04</u>	<u>19,048.76</u>	<u>14,375.28</u>
8150.00 · Gain/Loss on Disposal of Assets	0.00	-4,919.84	4,919.84
Total 8000.00 · Non-Operating Revenues	<u>6,007,367.79</u>	<u>4,671,609.11</u>	<u>1,335,758.68</u>
Total Income	<u>12,056,625.93</u>	<u>10,344,698.57</u>	<u>1,711,927.36</u>
Gross Profit	12,056,625.93	10,344,698.57	1,711,927.36
Expense			
7500.00 · Personnel & Benefits			
7510.00 · Salaries & Wages	1,859,188.92	1,617,609.68	241,579.24
7520.00 · Medicare	30,228.84	27,108.74	3,120.10
7530.00 · CalPERS Retirement	217,476.66	195,538.05	21,938.61
7550.00 · Group Insurance			
7550.10 · Health Benefits	535,066.30	479,321.48	55,744.82
7550.20 · Health Reimbursement Agreement	27,535.43	20,997.38	6,538.05
7550.30 · Life & AD&D	12,415.52	11,025.04	1,390.48
7550.40 · Dental Benefits	16,466.57	25,743.75	-9,277.18
7550.50 · Vision Benefits	2,449.92	2,964.09	-514.17
Total 7550.00 · Group Insurance	<u>593,933.74</u>	<u>540,051.74</u>	<u>53,882.00</u>
7560.00 · Group Insurance Retirees	143,445.73	129,855.25	13,590.48
7570.00 · Workers' Compensation	79,716.43	83,423.26	-3,706.83

Midway City Sanitary District
Statement of Revenues, Expenses and Changes in Net Position
3Q FY 2023-2024

	<u>Jul '23 - Mar 24</u>	<u>Jul '22 - Mar 23</u>	<u>\$ Change</u>
7575.00 · Uniforms & Laundry Service	14,670.57	10,746.91	3,923.66
7580.00 · Employee Reimbursements	8,519.99	7,094.87	1,425.12
Total 7500.00 · Personnel & Benefits	2,947,180.88	2,611,428.50	335,752.38
7600.00 · Operating Expenses			
7605.00 · Election Costs	0.00	91,109.98	-91,109.98
7610.00 · Board Meeting Expenses	5,582.04	3,296.89	2,285.15
7615.00 · Office Expenses	14,162.35	7,698.02	6,464.33
7620.00 · Operating & Office Expenses	12,873.33	18,705.99	-5,832.66
7625.00 · LAFCO	21,507.79	19,152.59	2,355.20
7630.00 · Services & Supplies			
7630.10 · Alarm Services	1,781.00	4,046.00	-2,265.00
7630.20 · Banking Services & Fees	4,829.40	3,888.56	940.84
7630.30 · GPS Services	31,124.73	41,451.44	-10,326.71
7630.40 · Janitorial Services & Supplies	8,084.79	7,319.82	764.97
7630.50 · Landscape Services	1,000.00	0.00	1,000.00
7630.60 · Payroll Services	16,351.23	12,940.73	3,410.50
7630.70 · Postage & Postage Machine	2,943.45	2,579.31	364.14
7630.80 · Wash & Detail Fleet & Vehicles	18,900.00	15,990.00	2,910.00
Total 7630.00 · Services & Supplies	85,014.60	88,215.86	-3,201.26
7635.00 · Printing & Publications	2,811.81	0.00	2,811.81
7640.00 · Permits Fees Testing & Taxes	22,367.06	20,021.52	2,345.54
7645.00 · Memberships Dues & Subscriptions	11,596.18	10,877.00	719.18
7650.00 · Education Training & Travel Exp	37,386.30	16,368.67	21,017.63
7655.00 · Education & Training	12,986.54	5,748.86	7,237.68
7660.00 · Employee Awards & Recognition	31,512.25	36,195.98	-4,683.73
7665.00 · Medical Exams & Testing	3,162.35	3,438.87	-276.52
7670.00 · Property & Liability Insurance	475,082.42	371,159.28	103,923.14
7675.00 · Claims Expenses	3,588.72	359.85	3,228.87
7680.00 · Gasoline & Diesel Fuel	14,729.42	14,408.69	320.73
7685.00 · Tonnage Disposal Fees			
7685.10 · Trash (Black Cart)	1,085,962.05	1,107,055.97	-21,093.92
7685.30 · Organics (Green Cart)	785,080.84	791,805.70	-6,724.86
Total 7685.00 · Tonnage Disposal Fees	1,871,042.89	1,898,861.67	-27,818.78
7690.00 · Containers/Carts			
7690.10 · Black Carts	93,509.75	98,825.47	-5,315.72
7690.20 · Blue Carts	89,593.88	98,419.03	-8,825.15
7690.30 · Green Carts	32,113.88	48,230.20	-16,116.32
Total 7690.00 · Containers/Carts	215,217.51	245,474.70	-30,257.19
7695.00 · Tools & Equipment	23,666.90	30,498.88	-6,831.98
7600.00 · Operating Expenses - Other	130.50	0.00	130.50
Total 7600.00 · Operating Expenses	2,864,420.96	2,881,593.30	-17,172.34
7700.00 · Repairs & Maintenance			
7700.05 · Buildings & Facilities	2,697.16	3,823.89	-1,126.73
7700.10 · CNG Facilities	19,587.76	31,896.61	-12,308.85
7700.15 · Vehicles	2,485.44	9,108.26	-6,622.82
7700.20 · Trash Trucks	100,479.66	133,732.56	-33,252.90
7700.25 · Vector Trucks	20,421.77	15,351.47	5,070.30

Midway City Sanitary District
Statement of Revenues, Expenses and Changes in Net Position
3Q FY 2023-2024

	<u>Jul '23 - Mar 24</u>	<u>Jul '22 - Mar 23</u>	<u>\$ Change</u>
7700.30 · Tires	61,182.79	68,931.03	-7,748.24
7700.35 · Restock Parts & Supplies	169,671.08	171,514.02	-1,842.94
7700.40 · Lift Station No. 1 Willow	57.62	0.00	57.62
7700.45 · Lift Station No. 2 Hammon	916.37	1,848.61	-932.24
7700.50 · Lift Station No. 3 Westminster	665.26	2,255.69	-1,590.43
7700.55 · Lift Station No. 4 Brookhurst	700.00	2,200.00	-1,500.00
7700.60 · Lift Station Maintenance	35,032.60	52,945.17	-17,912.57
7700.65 · Manholes	33,292.21	8,478.41	24,813.80
7700.75 · CCTV Inspection & Cleaning	249,992.59	0.00	249,992.59
7700.80 · Generators	10,259.05	0.00	10,259.05
7700.85 · Hazardous Waste Used/Mixed Oil	615.15	473.00	142.15
7700.95 · Other Repairs & Maintenance	155.06	0.00	155.06
Total 7700.00 · Repairs & Maintenance	708,211.57	502,558.72	205,652.85
7725.00 · Professional & Tech Services			
7725.10 · Audit & Financial Services	25,000.01	19,490.00	5,510.01
7725.20 · Engineering & Consulting	201,257.60	81,479.17	119,778.43
7725.30 · Legal Services Personnel	37,944.80	6,737.50	31,207.30
7725.40 · Legal Services General Counsel	88,754.20	90,560.32	-1,806.12
7725.50 · Information Technology	66,580.26	35,004.53	31,575.73
7725.70 · Prof & Consulting Services	43,371.35	18,387.00	24,984.35
7725.80 · SCADA System	5,490.31	3,934.11	1,556.20
7725.90 · Temporary Personnel	25,491.66	19,688.75	5,802.91
Total 7725.00 · Professional & Tech Services	493,890.19	275,281.38	218,608.81
7750.00 · Community Outreach & Programs			
7750.05 · Community & District Events	51,415.12	14,476.46	36,938.66
7750.10 · District Calendar	43,571.43	44,595.41	-1,023.98
7750.20 · Media & Program Development	33,692.00	20,509.80	13,182.20
7750.25 · Clean-up Events	12,264.58	6,907.63	5,356.95
7750.30 · Organics, Compost & SB1383 Exp	32,198.81	31,670.83	527.98
7750.35 · Fats Oil Grease (FOG) Program	17,075.00	8,875.00	8,200.00
Total 7750.00 · Community Outreach & Programs	190,216.94	127,035.13	63,181.81
7800.00 · Utilities			
7800.10 · Electricity	93,147.28	78,539.60	14,607.68
7800.20 · Natural Gas	810.43	151,220.70	-150,410.27
7800.30 · Natural Gas CNG Facilities	91,288.05	0.00	91,288.05
7800.40 · Phone & Internet	22,627.46	27,341.56	-4,714.10
7800.50 · Mobile Phone	4,970.75	2,572.07	2,398.68
7800.60 · Television	994.57	819.12	175.45
7800.70 · Underground Service Alerts	176.25	288.90	-112.65
7800.80 · Water & Sewer	1,855.57	2,922.96	-1,067.39
Total 7800.00 · Utilities	215,870.36	263,704.91	-47,834.55
7900.00 · Depreciation & Amortization	0.00	1,084,091.37	-1,084,091.37
Total Expense	7,419,790.90	7,745,693.31	-325,902.41
Net Income	4,636,835.03	2,599,005.26	2,037,829.77

MIDWAY CITY SANITARY DISTRICT

BUDGET vs. ACTUAL

Q3 FY 2023-2024

		FY 2023-24	FY 2023-24	PERCENT of
		ACTUAL	BUDGET	BUDGET
SUMMARY				
1	REVENUES			
2	Trash & Sewer Collection Fees	4,967,338	7,160,000	69.4%
3	Franchise Fees	1,012,352	1,200,000	84.4%
4	Property Taxes	911,447	1,478,000	61.7%
5	Pass-Thru Property Tax Funds	2,335,038	3,600,000	64.9%
6	Investment Income	2,727,459	2,250,000	121.2%
7	Other Revenue Sources	102,992	271,000	38.0%
8	TOTAL REVENUES	\$ 12,056,626	\$ 15,959,000	75.5%
9	EXPENSES			
10	Salaries and Wages	1,859,189	3,112,000	59.7%
11	Benefits	1,064,801	1,786,200	59.6%
12	Tonnage Fees	1,871,043	2,650,000	70.6%
13	Repairs and Maintenance	707,596	859,000	82.4%
14	Depreciation & Amortization Expense	-	1,519,900	0.0%
15	Other Operating Expenses	1,917,161	\$ 4,550,658	42.1%
16	TOTAL EXPENSES	\$ 7,419,791	\$ 14,477,758	51.2%
17	Net Resources Over/(Under) Expenses	4,636,835	1,481,242	
18	ACTUAL/BUDGET	\$ 12,056,626	\$ 15,959,000	

		FY 2023-24	FY 2023-24	PERCENT of
		ACTUAL	BUDGET	BUDGET
REVENUES				
1	OPERATING REVENUES			
2	Trash & Sewer Collection Fees	4,967,338	7,160,000	69.4%
3	Additional Container & Service Fees	12,292	12,000	102.4%
4	Franchise Fees	1,012,352	1,200,000	84.4%
5	Sewer Plan Check & Inspection Fees	44,248	45,000	98.3%
6	Sewer Connection Fees	13,028	14,000	93.1%
7	OPERATING REVENUES	\$ 6,049,258	\$ 8,431,000	71.8%
8	NON-OPERATING REVENUES			
9	Property Tax Secured	813,058	1,336,200	60.8%
10	Property Tax Unsecured	34,074	40,000	85.2%
11	Property Tax Supplemental	20,244	30,000	67.5%
12	Homeowner's Property Tax Relief	2,650	6,000	44.2%
13	Public Utility Tax & Reg. Railroad	32,497	64,000	50.8%
14	Pass thru Property Taxes County of Orange	334,439	400,000	83.6%
15	Pass thru Property Taxes City of Westminster	2,000,599	3,200,000	62.5%
16	Investment Income	2,727,459	2,250,000	121.2%
17	Interest on Undistributed Taxes	8,925	1,800	495.8%
18	Other Revenue	33,424	200,000	16.7%
19	Gain/(Loss) on Disposal of Capital Assets	-	-	0.0%
21	NON-OPERATING REVENUES	\$ 6,007,368	\$ 7,528,000	79.8%
22	TOTAL REVENUES	\$ 12,056,626	\$ 15,959,000	75.5%

MIDWAY CITY SANITARY DISTRICT

BUDGET vs. ACTUAL

Q3 FY 2023-2024

		FY 2023-24	FY 2023-24	PERCENT of
		ACTUAL	BUDGET	BUDGET
BOARD OF DIRECTORS				
23	Directors' Fees (salaries)	70,800	115,000	61.6%
24	Medicare	990	1,600	61.9%
25	Group Insurance	73,715	120,000	61.4%
26	Workers' Compensation Insurance	400	400	100.0%
27	Director Reimbursements	-	-	0.0%
28	Board Meeting Expenses	5,582	5,000	111.6%
29	Operating Expense	3,250	3,500	92.9%
30	Services & Supplies	2,655	4,000	66.4%
31	Board Development & Travel Expenses	7,277	45,000	16.2%
32	TOTAL BOARD OF DIRECTORS	\$ 164,670	\$ 294,500	55.9%

MIDWAY CITY SANITARY DISTRICT

BUDGET vs. ACTUAL

Q3 FY 2023-2024

		FY 2023-24	FY 2023-24	PERCENT of
		ACTUAL	BUDGET	BUDGET
ADMINISTRATION				
33	Salaries & Wages	622,323	1,200,000	51.9%
34	Medicare	10,375	17,000	61.0%
35	CalPERS Retirement	77,210	150,000	51.5%
36	CalPERS CEPPT Trust Reimbursement	-	-	0.0%
37	Group Insurance	137,128	229,500	59.8%
38	Group Insurance - Retirees	64,961	90,000	72.2%
39	Group Insurance Retirees Trust Reimbursement	-	(90,000)	0.0%
40	Workers' Compensation Insurance	3,316	4,200	79.0%
41	Uniforms & Laundry Services	2,234	750	297.9%
42	Employee Reimbursements	3,212	5,500	58.4%
43	Unemployment Benefits	-	-	0.0%
43	Office Expenses & Supplies	14,126	15,000	94.2%
44	Operating Expenses	4,285	20,000	21.4%
45	Local Govt. Formation Commission (LAFCO)	21,508	21,508	100.0%
46	Services & Supplies	32,479	40,000	81.2%
47	Printing & Publications	2,812	2,000	140.6%
48	Permits Fees Testing & Taxes	1,547	3,500	44.2%
49	Memberships Dues & Subscriptions	10,474	15,000	69.8%
50	Staff Development & Travel	27,484	50,000	55.0%
51	Education & Training	3,886	5,000	77.7%
52	Employee Awards Incentives & Recognition	31,224	50,000	62.4%
53	Medical Exams & Testing	640	2,000	32.0%
54	Property & Liability Insurance	106,000	106,000	100.0%
55	Claims Expense	(324)	-	0.0%
56	Gasoline & Diesel Fuel	2,045	4,000	51.1%
57	Repairs & Maintenance	1,922	10,000	19.2%
58	Audit & Financial Services	25,000	25,000	100.0%
59	Legal Services Personnel	37,945	55,000	69.0%
60	Legal Services General Counsel	88,754	120,000	74.0%
61	Information Technology	60,727	70,000	86.8%
62	Professional & Consulting Services	28,358	55,000	51.6%
63	Temporary Personnel	25,492	50,000	51.0%
64	Community Outreach & District Events	51,601	125,000	41.3%
65	District Calendar	43,571	43,600	99.9%
66	Media & Program Development	33,692	60,000	56.2%
67	Newsletters	-	-	0.0%
68	Utilities	17,959	35,000	51.3%
69	Depreciation & Amortization Expenses	-	75,000	0.0%
70	TOTAL ADMINISTRATION	\$ 1,593,965	\$ 2,664,558	59.8%

MIDWAY CITY SANITARY DISTRICT

BUDGET vs. ACTUAL

Q3 FY 2023-2024

		FY 2023-24	FY 2023-24	PERCENT of
		ACTUAL	BUDGET	BUDGET
FLEET MAINTENANCE				
71	Salaries & Wages	227,476	357,000	63.7%
72	Medicare	3,900	5,000	78.0%
73	CalPERS Retirement	30,769	50,000	61.5%
74	CalPERS CEPPT Trust Reimbursement	-	-	0.0%
75	Group Insurance	56,194	100,000	56.2%
76	Group Insurance Retirees	3,865	10,000	38.6%
77	Group Insurance Retirees Trust Reimbursement	-	(10,000)	0.0%
78	Workers' Compensation Insurance	9,000	9,000	100.0%
79	Uniforms & Laundry Services	2,895	4,500	64.3%
80	Employee Reimbursements	376	2,000	18.8%
81	Services & Supplies	3,397	4,000	84.9%
82	Staff Development & Travel Expenses	1,154	5,000	23.1%
83	Education & Training	4,461	5,000	89.2%
84	Medical Exams & Testing	622	800	77.7%
85	Property & Liability Insurance	80,000	80,000	100.0%
86	Gasoline & Diesel Fuel	3,188	6,000	53.1%
87	Tools & Equipment	23,775	40,000	59.4%
88	Repairs & Maintenance	2,648	15,000	17.7%
89	Hazardous Waste Used/Mixed Oil	615	3,000	20.5%
90	Information Technology	173	3,000	5.8%
91	Utilities	876	2,500	35.1%
92	Depreciation & Amortization Expenses		6,900	0.0%
93		\$ 455,384	\$ 698,700	65.2%

MIDWAY CITY SANITARY DISTRICT

BUDGET vs. ACTUAL

Q3 FY 2023-2024

		FY 2023-24	FY 2023-24	PERCENT of
		ACTUAL	BUDGET	BUDGET
SOLID WASTE				
94	Salaries & Wages	664,397	1,000,000	66.4%
95	Medicare	10,458	18,000	58.1%
96	CalPERS Retirement	65,061	190,000	34.2%
97	CalPERS CEPPT Trust Reimbursement	-	-	0.0%
98	Group Insurance	239,473	335,000	71.5%
99	Group Insurance Retirees	49,480	76,000	65.1%
100	Group Insurance Retirees Trust Reimbursement	-	(76,000)	0.0%
101	Workers' Compensation Insurance	54,000	54,000	100.0%
102	Uniforms & Laundry Services	7,078	12,000	59.0%
103	Employee Reimbursements	3,225	6,000	53.7%
104	Operating Expenses	1,468	6,000	24.5%
105	Services & Supplies	38,538	66,500	58.0%
106	Staff Development & Travel Expenses	-	10,000	0.0%
107	Education & Training	2,571	10,000	25.7%
108	Medical Exams & Testing	1,010	5,000	20.2%
109	Property & Liability Insurance	195,082	196,000	99.5%
110	Claims Expense	2,913	10,000	29.1%
111	Gasoline & Diesel Fuel	2,403	7,500	32.0%
112	Tonnage Fees Trash (black cart)	1,085,962	1,550,000	70.1%
113	Tonnage Fees Recycling (blue cart)	-	-	0.0%
114	Tonnage Fees Organics (green cart)	785,081	1,100,000	71.4%
115	Refuse, Recycling, and Organic Containers	215,218	300,000	71.7%
116	Repairs, Maintenance, Tires, and Restock Parts	328,624	425,000	77.3%
117	Repairs & Maintenance CNG Facilities	19,588	75,000	26.1%
118	Information Technology	2,300	30,000	7.7%
119	Professional & Consulting Services	7,507	60,000	12.5%
120	Clean-up Events	12,079	30,000	40.3%
121	Organics & Compost Giveaway	32,199	40,000	80.5%
122	Utilities	69,353	85,000	81.6%
123	Natural Gas Fuel CNG Facilities	90,418	140,000	64.6%
124	Depreciation & Amortization Expenses		850,000	0.0%
125	TOTAL SOLID WASTE	\$ 3,985,483	\$ 6,611,000	60.3%

MIDWAY CITY SANITARY DISTRICT

BUDGET vs. ACTUAL

Q3 FY 2023-2024

		FY 2023-24	FY 2023-24	PERCENT of
		ACTUAL	BUDGET	BUDGET
SEWER DEPARTMENT				
126	Salaries & Wages	274,193	440,000	62.3%
127	Medicare	4,506	6,000	75.1%
128	CalPERS Retirement	44,437	125,000	35.5%
129	CalPERS CEPPT Trust Reimbursement	-	-	0.0%
130	Group Insurance	87,425	140,000	62.4%
131	Group Insurance Retirees	25,140	40,000	62.9%
132	Group Insurance Retirees Trust Reimbursement	-	(40,000)	0.0%
133	Workers' Compensation Insurance	13,000	15,500	83.9%
134	Uniforms & Laundry Services	2,464	3,500	70.4%
135	Employee Reimbursements	1,707	3,000	56.9%
136	Operating Expenses	3,892	6,000	64.9%
137	Services & Supplies	7,981	10,500	76.0%
138	Permits Fees Testing & Taxes	20,820	25,000	83.3%
139	Memberships Dues & Subscriptions	1,122	2,000	56.1%
140	Staff Development & Travel Expenses	1,759	10,000	17.6%
141	Education & Training	2,069	10,000	20.7%
142	Medical Exams & Testing	891	1,000	89.1%
143	Property and Liability Insurance	94,000	94,000	100.0%
144	Claims Expense	1,000	10,000	10.0%
145	Gasoline & Diesel Fuel	7,094	9,000	78.8%
146	Repairs & Maintenance	354,815	250,000	141.9%
147	Emergency Repairs	-	150,000	0.0%
148	Engineering & Consulting	201,258	500,000	40.3%
149	Professional & Consulting Services	7,507	500,000	1.5%
150	Information Technology	8,870	15,000	59.1%
151	CCTV and Cleaning of District Sewer Lines	-	1,200,000	0.0%
152	Fats, Oils & Grease (FOG) Program	17,075	25,000	68.3%
153	Resident Lateral Assistance Program	-	9,000	0.0%
154	Utilities	36,394	51,500	70.7%
155	Natural Gas Fuel CNG Station	870	10,000	8.7%
156	Depreciation & Amortization Expenses		588,000	0.0%
157	TOTAL SEWER	\$ 1,220,289	\$ 4,209,000	29.0%

MIDWAY CITY SANITARY DISTRICT

BUDGET vs. ACTUAL

Q3 FY 2023-2024

		FY 2023-24	FY 2023-24	PERCENT of
		ACTUAL	BUDGET	BUDGET
MIDWAY CITY SANITARY DISTRICT				
158	REVENUES	\$ 12,056,626	\$ 15,959,000	75.5%
159	EXPENSES	\$ 7,419,791	\$ 14,477,758	51.2%
160	REVENUES - EXPENSES =	\$ 4,636,835	\$ 1,481,242	

		FY 2023-24	FY 2023-24	PERCENT of
		ACTUAL	BUDGET	BUDGET
161	Sewer System Department	1,220,289	4,209,000	29.0%
162	Solid Waste Department	3,985,483	6,611,000	60.3%
163	Fleet Maintenance Department	455,384	698,700	65.2%
164	Administration Department	1,593,965	2,664,558	59.8%
165	Board of Directors	164,670	294,500	55.9%
166	TOTAL SUMMARY BY DEPT	\$ 7,419,791	\$ 14,477,758	51.2%

		FY 2023-24	FY 2023-24	PERCENT of
		ACTUAL	BUDGET	BUDGET
CAPITAL OUTLAY & IMPROVEMENTS BUDGET				
167	<i>District Offices & Yard</i>			
168	Solar Project Construction	602,836	735,000	82.0%
169	District Building Project Construction	2,810,946	3,362,000	83.6%
170	District Buildings Facility, Features, & Furnishings	235,405	250,000	94.2%
171	District Buildings Technology	29,524	25,000	118.1%
172	New Class C Vehicles	32,549	80,000	40.7%
173	<i>Fleet Maintenance</i>			
174	None			
175	<i>Solid Waste</i>			
176	3 New Side Loader Trash Trucks	1,358,280	1,400,000	97.0%
177	Rebuilt Engines & Packers for CNG Trash Trucks	-	60,000	0.0%
178	<i>Sewer</i>			
179	Plan and Document Scanner and Plotter	-	10,000	0.0%
180	<i>Miscellaneous</i>			
181	Payments Towards Unfunded Liabilities	-	-	0.0%
182	Payment Towards 115 CEPPT Trust	-	250,000	0.0%
183	TOTAL CAPITAL OUTLAY & IMPROVEMENTS	\$ 5,069,541	\$ 6,172,000	82.1%

AGENDA ITEM #6D

Date: May 21, 2024

To: Board of Directors

From: Robert Housley, General Manager

Prepared by: Ashley Davies, Director of Services and Program Development

Subject: Approve the May 1, 2024 Outreach Committee Recommendations

BACKGROUND

At the April 5, 2022 meeting the Board approved the formation of a standing Outreach Committee. The Outreach Committee usually meets on the first Wednesday of each month to plan and discuss upcoming outreach activities.

DISCUSSION

The Outreach Committee met on May 1, 2024 and their recommendations are as follows:

1. The Committee recommends that the District participate in two radio outreach programs. Two directors will attend each radio program. Appointments will be set up in May.
2. The Committee recommends the attached Sponsorship Package and package options for the 85th Anniversary Celebration.

FISCAL IMPACT

The potential fiscal impact of the Outreach Committee's recommendations are as follows:

- Monthly radio outreach \$4,000

STAFF RECOMMENDATION

Staff recommends that the Board of Directors approve the Outreach Committee's recommendations as presented.

ATTACHMENTS:

1. 85th Anniversary Celebration Sponsorship Package

Sponsorship Package

Celebrating



Years

1939-2024

85th Anniversary Highlights

PRESENTED BY: Midway City Sanitary District

DATE: Saturday, September 14, 2024

TIME: 10 AM - 1 PM

LOCATION: 14451 Cedarwood St. Westminster, CA 92683

COST: Admission is FREE with one lunch provided per person in attendance

Sponsorship Opportunities

PLATINUM SPONSOR	\$10,000
GOLD SPONSOR	\$3,000
SILVER SPONSOR	\$1,000
OTHER	In-kind or monetary

FOR MORE INFORMATION CONTACT:

**Ashley Davies, Director of Services and Program Development at
714-893-3553 or adavies@midwaycitysanityca.gov**

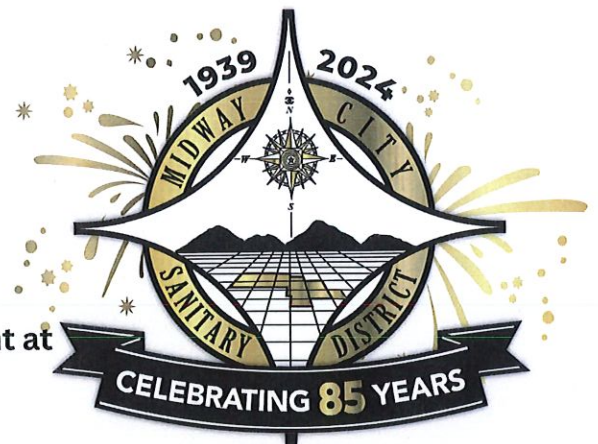

85th Anniversary Sponsorship Opportunities

PLATINUM SPONSOR - 1

Sponsor Investment \$10,000

As a Platinum Sponsor you will receive:

- Booth
- Banner at event
- Acknowledgement as top sponsor during event
- Name/logo on program
- Special social media recognition

GOLD SPONSOR - 3

Sponsor Investment \$3,000

As a Gold Sponsor you will receive:

- Booth
- Banner at event
- Acknowledgement during event
- Name/logo on program
- Mention in related social media

SILVER SPONSOR

Sponsor Investment \$1,000

As a Silver Sponsor you will receive:

- Banner at event
- Acknowledgement during event
- Name/logo on program
- Mention in related social media

OTHER

Sponsor Investment In-kind or monetary

As a sponsor you will receive:

- Name/logo in program
- Mention in related social media

FOR MORE INFORMATION CONTACT:

Ashley Davies, Director of Services and Program Development at
714-893-3553 or adavies@midwaycitysanityca.gov



85th Anniversary Sponsorship Form

COMPANY NAME: _____
ADDRESS: _____ CITY, ZIP: _____
CONTACT PERSON: _____
CONTACT PHONE NUMBER: _____
EMAIL: _____

SPONSOR LEVEL/AMOUNT:

- PLATINUM \$10,000 GOLD \$3,000 SILVER \$1,000
 OTHER _____

Please return completed form and donation to:

Midway City Sanitary District
Attn: Ashley Davies
14451 Cedarwood St.
Westminster, CA 92683

Make checks payable to: Midway City Sanitary District

Forms must be completed and returned by September 4, 2024

Thank you!



AGENDA ITEM #6E

Date: May 21, 2024

To: Board of Directors

From: Robert Housley, General Manager

Prepared by: Milo Ebrahimi, P.E., District Engineer

Subject: Receive and File the Engineer Report for April 2024

BACKGROUND

District Engineer prepares a monthly report for the Board of Directors to inform about engineering and engineering related activities. This report includes monthly progress of District projects, reviewed plans, sewer department projects and activities, trainings and meetings, preventive maintenances and repairs of the district assets, and more.

DISCUSSION

1. District Building Project by Woodcliff

1.1. The new office building:

- 1.1.1. Contractor has finished the new office building.
- 1.1.2. Complete punch list has been created by Architect.
- 1.1.3. Contractor is working on the punch list items.

1.2. The locker room building:

- 1.2.1. Contractor has finished the Locker room building.
- 1.2.2. Complete punch list has been created by Architect.
- 1.2.3. Contractor is working on the punch list items.

1.3. Landscaping and sitework:

- 1.3.1. Contractor has finished the landscape and the sitework.
- 1.3.2. Complete punch list has been created by Architect.
- 1.3.3. Contractor is working on the punch list items.

1.4. Solar Carport:

- 1.4.1. Six charging stations are installed by the Contractor.
- 1.4.2. A router needs to be installed for internet connectivity.
- 1.4.3. A wiring issue needs to be resolved.
- 1.4.4. Final inspection is needed by City at the time of completion.

2. Plans Reviewed
 - 2.1. Sewer permits (this month): 18.
 - 2.2. Sewer permits (this fiscal year): 160.
 - 2.3. Development projects (trash enclosures and/or sewer lines): 5.
3. Westminster Mall project
 - 3.1. The official Conditional Will Serve Letter (Letter) was sent to the developer's engineer by District without any proposed changes to the letter by the developer's engineer at this point. The Letter was submitted to City's Planning Department with other improvement plans on April by the developer's engineer.
 - 3.2. The only comments on the Letter by the developer's engineer was the ownership of the backbone infrastructure which is in question yet.
4. Sewer department projects
 - 4.1. Sewer System Master Plan (SSMP) Project by AKM
 - 4.1.1. SSMP is in progress. There is a monthly meeting with AKM about the progress.
 - 4.1.2. AKM will finish in about 8 months. A few months' delay is due to Amendment No. 2, which was approved by the Board on March 19, 2024, to the original agreement with AKM. GPS survey of 525 manholes will be performed for engineering analysis and Hydraulic Model.
 - 4.1.3. AKM worked on Addendum No. 2 line item which is Sewer GIS, Survey of Manholes, and Hydraulic Model Update (task 12 of the project).
 - 4.2. Sewer System Cleaning and CCTV Project By Empire Pipe Cleaning & Equipment
 - 4.2.1. District issued Notice To Proceed letter for the entire jurisdiction.
 - 4.2.2. The contractor has finished 27 percent of the project so far.
 - 4.2.3. Contractor will finish in about 8 months.
 - 4.2.4. District Engineer is collaborating with Contractor and AKM to link the CCTV inspection report with GIS.
5. Sewer Department Activities
 - 5.1. There were three sewer emergency cases this month.
 - 5.1.1. Broken sewer pipe at the intersection of Webber Pl and Pembroke Ln: District is working on repairing of the sewer line. District is also working with City on repairing of the street at this location.
 - 5.1.2. Blocked and possibly damaged siphon at the intersection of Westminster Blvd and Springdale St: District is working with a consultant to prepare an emergency construction repair plans and specs for construction to restore the sewer flow.

- 5.1.3. Broken electrical panel at Westminster lift station due to electrical surcharge: The panel was repaired by a contractor in an emergency case. The pumps operation was restored from manual to automatic again.
- 5.2. There was no sewer system overflow this month.
- 5.3. 73 hotspot locations were cleaned this month.
- 5.4. About 48 hotspot locations were checked weekly.
- 5.5. About 51,000 linear feet (9.7 miles) of sewer line was cleaned on the west side.
6. Trainings and Meetings
 - 6.1. District Engineer attended monthly meetings with District Engineer of Costa Mesa Sanitary District.
 - 6.2. District Engineer attended Development Review Team meetings at the City of Westminster.
 - 6.3. Mechanic Lead, Sewer Lead, and Refuse Lead attended Supervisor Training at Dale Carnegie.
 - 6.4. Mechanic Lead, Sewer Lead, Refuse Lead attended, District Engineer and most of the office staff participated in CPR, First Aid, and AED training.
7. Preventive Maintenances (PM) and Repairs
 - 7.1. Contractor performed the monthly PM services on the CNG station at the yard.
 - 7.2. Spectrum performed maintenance on internet equipment at the new building.
 - 7.3. Contractor performed the yearly backflow inspection services on all backflow devices inside the yard and the lift stations.
 - 7.4. Contractor performed PM services on all the pumps at the lift stations.
 - 7.5. A repair is needed on the portable generator in the yard. The portable generator is still not operational due to more issues. The contractor will need more parts to finish the repair.
8. Regulation and Reporting
 - 8.1. California Air Resources Board (CARB)
 - 8.1.1. None.
 - 8.2. California Water Resources Control Board (CWRCB)
 - 8.2.1. California Integrated Water Quality System (CIWQS): monthly report submitted to the board.

FISCAL IMPACT

Informational report only.

STAFF RECOMMENDATION

Staff recommend that the Board of Directors approve and file the Engineer Report.

AGENDA ITEM #6F

Date: May 21, 2024

To: Board of Directors

From: Robert Housley, General Manager

Prepared by: Robert Housley, General Manager

Subject: Declare Four Class C Vehicles, One Sewer Vactor Truck, and Three Other Pieces of Equipment to be Surplus Property and Authorize the General Manager to Dispose of said Vehicles and Equipment Pursuant to the Methods Set Forth in the District's Purchasing Policy and Procedures

BACKGROUND

Pursuant to Section 15 of the District's Purchasing Policy and Procedures, the Board of Directors shall approve the disposition of all Surplus Property. Surplus property may be offered for sale using any of the following processes identified; transferred to another department; traded-in for new equipment or material; donated; recycled; or disposed of through the solid waste collection system. All Surplus Property that is for sale shall be sold "as is" and "where is," with no warranty, guarantee, or representation of any kind, expressed or implied, as to the condition, utility or usability of the property offered for sale or as otherwise directed by the Board of Directors. Appropriate methods of sale are as follows: public auction; sealed bids; negotiated sale; sell as salvage; or as otherwise directed by the Board of Directors.

DISCUSSION

Due to the California Air Resources Board Regulation "Advanced Clean Fleets" (effective October 1, 2023), which require that government agencies begin remove aging fossil fuel powered vehicles and equipment from their fleets and replace them with Zero Emissions Vehicles (ZEV's) such as electric or hydrogen powered ones, the District has identified several vehicles that fall within the age limitation of the regulations and need to be removed from its fleet. The vehicles being removed will eventually be replaced with ZEV's. The list also includes other vehicles and equipment that have reached their useful life cycle, are no longer reliable, and need to be removed and eventually replaced to ensure the continued operations and safety of the District.

Year	Vehicle/Equipment	ID	Department	Reason For Disposal	Cost Basis
1990	Steam Cleaner for Wash Rack	-	Garage	Reached Useful Life	\$ 6,606.61
1998	Ford F250 Pickup (Gasoline)	G5	Garage	Advanced Clean Fleets	\$ 19,814.77
2009	Ford F350 Service Truck (Diesel)	G2	Garage	Completely Totaled Engine	\$ 47,360.63
1999	Ford F450 Flat Bed Truck (Gasoline)	T9	Solid Waste	Advanced Clean Fleets	\$ 23,694.34
2004	Portable Steam Cleaner (Trailer)	-	Solid Waste	Reached Useful Life	\$ 6,406.00
2003	Sterling Vactor Truck (Diesel)	M64	Sewer	Advanced Clean Fleets	\$238,910.85
2004	Trailer Mounted Portable Generator (Diesel)	-	Sewer	Reached Useful Life	\$ 29,046.37
2010	Ford F150 Pickup (Gasoline)	S1	Sewer	Reached Useful Life	\$ 24,495.23
	Total Cost Basis:				\$396,334.80

The list includes four class c vehicles, a sewer vacor truck and three pieces of aging equipment. The District has a new solar panel grid with six vehicle charging stations. These charging stations will be able to recharge newly acquired ZEV' at little to no fueling cost to the District. The class c vehicles will be budgeted for and replaced with electric vehicles in the upcoming FY 2024-2025 budget as well as the replacement of the steam cleaners and a new generator. The sewer vacor truck will not be replaced at this time.

FISCAL IMPACT

There is no negative fiscal impact to declare these items as Surplus Property. The sale or trade in value of vehicles and equipment will help offset costs for the purchase of new equipment and electric vehicles, which will be presented to the Board of Directors at a future date.

STAFF RECOMMENDATION

Staff recommends that the Board of Directors declare the vehicles and equipment listed as Surplus Property and authorize the General Manager to dispose of said vehicles and equipment pursuant to any of the methods of sale set forth in Section 15 of the District's Purchasing Policy and Procedures.

ATTACHMENTS:

None.

AGENDA ITEM #6G

Date: May 15, 2024

To: Board of Directors

From: Robert Housley, General Manager

Prepared by: Robert Housley, General Manager

Subject: Approve the April 10, 2024 Franchise Committee Report

BACKGROUND

The Midway City Sanitary District Franchise Committee met with CR&R on April 10, 2024 at 12:00 PM.

In attendance were:

MCS D Board Director, Tyler Diep
MCS D Board Director, Charlie Chi Nguyen
MCS D General Manager, Robert Housley
MCS D Director of Services & Program Development
CR&R, Sr. Regional VP, Julie Barreda
CR&R, Sr. Sustainability Manager, Mike Carrey
CR&R, Sustainability Specialist, Gabriel Angulo

The following items were discussed:

1. CR&R will continue to set up meetings with customers to talk about the recycling, organics, and food waste programs and how to right size their services.
2. MCS D will partner with CR&R to attend outreach events when available.
3. MCS D staff and board members will continue to reach out to Westminster School District and Oceanview School District to see if they are interested in having recycling and food waste/organics programs for the students in the next school year. CR&R reaffirmed that they would assist MCS D with the programs.
4. MCS D is continuing to review and update its bin enclosure requirements. MCS D will work with CR&R to also review and provide comments on the requirements before approved.
5. The Committee decided to meet on a bi-monthly basis instead of monthly.

The next Franchisee Committee meeting is planned for June 19, 2024, at 12:00 PM.

FINANCIAL IMPACT

No fiscal impact.

STAFF RECOMMENDATION

Staff recommends that the Board of Directors approve the franchise committee report.

AGENDA ITEM #8A

Date: May 21, 2024

To: Board of Directors

From: Robert Housley, General Manager

Prepared by: Cynthia Olsder, Board Secretary

Prepared by: Discuss and Consider the Ballots for Orange County LAFCO
Regular Special District Member Seat

BACKGROUND

The Orange County Local Agency Formation Commission (OC LAFCO) Regular Special District Member seat is now open. The OC LAFCO Executive Officer accepted nominations for this seat from March 11 through April 15, 2024. The current term for this seat expires June 30, 2024.

DISCUSSION

On May 13, 2024, OC LAFCO received a letter of withdrawal from candidate Joe Muller, Director of South Coast Water District from the OC LAFCO appointment process for the special district regular member. However, Ballots must still be received by 4:00 P.M. on Monday, June 10, 2024, and will be tallied by OC LAFCO staff and results announced by electronic email by Monday, June 17, 2024.

Attached are the ballot and supplemental information for candidates of the regular special district member seat. Only the Presiding Officer or designee, as identified in the "Declaration of Qualification to Vote" previously received by OC LAFCO, completes the ballot. Only one ballot from each agency will be accepted for the regular special district member and one ballot from each agency for the alternate special district member.

STAFF RECOMMENDATION

Staff recommends that the Board discuss and provide direction.

FISCAL IMPACT

None.

ATTACHMENTS:

1. Letter to OC LAFCO Joe Muller withdrawal
2. BALLOT – OC LAFCO Special District Regular Member Seat
3. Supplemental Information of James R. Fidler and Joe Muller
4. OC LAFCO Ballot



**SOUTH COAST
WATER DISTRICT**

Partnering With The Community

Board of Directors

Doug Erdman
President

Scott Goldman
Vice President

Rick Erkeneff
Director

Bill Green
Director

Joe Muller
Director

May 13, 2024

Carolyn Emery
Executive Officer
OC LAFCO
2677 N. Main Street, Suite 1050
Santa Ana, CA 92705

Dear Ms. Emery:

I want to thank you and your team for your efforts relative to the Orange County Local Agency Formation Commission (OC LAFCO) Special District Member election process and notify you of my decision to withdraw my name from consideration for this seat.

In my outreach to the other 26 special districts countywide, I have had the opportunity to present my interest and qualifications before many of the various boards of directors, along with current LAFCO Special District member Jim Fisler, and to field questions from members of these boards. Commissioner Fisler, who ably represents Mesa Water District®, clearly has represented many of these districts well at OC LAFCO, and it is my pleasure to provide my endorsement of his reelection.

Thank you again for your assistance and leadership and best regards.

Sincerely,

Joseph L. Muller
Director
South Coast Water District

CC: ISDOC Membership
Heather Baez, Municipal Water District of Orange County

From: [Carolyn Emery](#)
To: [Cynthia Olsder](#)
Cc: [Cheryl Carter-Benjamin](#)
Subject: BALLOT - Orange County LAFCO Special District Regular Member Seat
Date: Monday, May 6, 2024 9:40:34 AM
Attachments: [image001.png](#)
[James Fisler - Supplemental Information.pdf](#)
[Joe Muller - Supplemental Information.pdf](#)
[2024 OC LAFCO Ballot - Special District Member \(Midway City SD\).pdf](#)
[2024 OC LAFCO Ballot - Special District Member \(Midway City SD\).pdf](#)

Dear Presiding Officer/Designee (c/o District Clerk/Secretary):

In 2011, the Special Districts Selection Committee approved conducting the OC LAFCO special district appointment process by electronic mail. The voting period for the OC LAFCO Regular member seat officially opens today, **Monday, May 6** and closes on **Monday, June 10, 2024 at 4:00 p.m.**

The ballot and supplemental information for candidates of the regular special district member seat are attached to this email. Please ensure that only the Presiding Officer or designee, as identified in the “Declaration of Qualification to Vote” previously received by OC LAFCO, completes the ballot. For your convenience, the fillable ballot includes the voting designee(s) as provided in your declaration. Additionally, the ballot allows for electronic signatures that shall have the same force and effect as the use of a “wet” or manual signature.

Ballots returned electronically shall be submitted to **OC LAFCO Commission Clerk, Cheryl Carter-Benjamin** at ccarter-benjamin@oclafco.org or by regular mail at OC LAFCO, 2677 N. Main Street, Suite 1050, Santa Ana, CA 92705. As a note, only one ballot from each independent district will be accepted by OC LAFCO by the closing date and time previously indicated in this email. In accordance with State law and the Special District Selection Committee Bylaws, any ballot received (electronically or by regular mail) by the Executive Officer or her designee after the closing date and time will be deemed invalid.

Ballots will be tallied by OC LAFCO staff and results announced by electronic email by **Monday, June 17, 2024**. If you have any questions regarding the process, you may contact me at (714) 640-5100 or by email at cemery@oclafco.org.

Regards,
Carolyn Emery
Executive Officer
cemery@oclafco.org
714.640.5100 – Office



BOARD OF DIRECTORS

Shawn Dewane
President, Division V

Marice H. DePasquale
Vice President, Division III

Jim Atkinson
Director, Division IV

Fred R. Bockmiller, P.E.
Director, Division I

James R. Fisler
Director, Division II

**RE: Declaration of Candidacy of James R. Fisler for Re-Election to
OC LAFCO representing the Special Districts of Orange County**

Greetings,

It has been my honor to serve you on the Orange County Local Agency Formation Commission (OC LAFCO) as your Special District Commissioner. Initially elected in July 2019 to the OC LAFCO voting member seat, I was re-elected in 2020 by Orange County's Independent Special Districts. Previously, I was elected to serve as the Special District Alternate Commissioner by the Independent Special Districts Selection Committee in 2011, and re-elected in 2014 and 2018.

During my service since 2011, I have sat on the dais and participated fully in all OC LAFCO discussions on all agenda items, and thus have broad knowledge of the OC LAFCO process and experience as a Commissioner. As such, I am the most experienced and qualified candidate.

I have been an effective Commissioner at OC LAFCO who has positively influenced decisions that have benefitted special districts and protected local control, while also safeguarding the interests of over 3 million Orange County residents.

I have been a strong advocate for the Special Districts of Orange County on OC LAFCO, as well as at the Independent Special Districts of Orange County (ISDOC) where I served as President in 2017 and 2018, and where I reduced ISDOC member dues by 75 percent.

I have personally visited all of the Independent Special Districts in Orange County multiple times over the past 12+ years. It has been a distinct honor to serve Orange County's Special Districts as a voting member at OC LAFCO to ensure the economical, effective, and efficient delivery of government services to the public.

As a voice for Special Districts serving the communities of Orange County, I have delivered on my promise to you that OC LAFCO would be more of a facilitator than an initiator of actions. Additionally, I remain committed to enhancing communications and information-sharing with you. This is now reflected in OC LAFCO's work-plan.

Lastly, to achieve my goal of providing transparency and strong leadership for you at OC LAFCO, for the past four years and counting, I have been distributing quarterly editions of *The Special Districts Dialogue* newsletter which provides an update on the Commission's recent activities relevant to Special Districts. I hope you find the newsletter information valuable, and I welcome your feedback.

Feel free to contact me at 714.423.4351 with any questions or requests regarding OC LAFCO, and please see the my statement of qualifications that accompanies this letter. Thank you for your consideration of my knowledge, experience, commitment, and results. I hope to receive your vote for this very important seat.

Sincerely,

James R. Fisler
OC LAFCO Commissioner and Mesa Water Director

Re-Elect James R. Fisler to OC LAFCO

*** KNOWLEDGE * EXPERIENCE * COMMITMENT * RESULTS ***

James R. Fisler – Mesa Water District Director



- **Orange County Local Agency Formation Commission (OC LAFCO)** Special District Commissioner, 2019-present
- **OC LAFCO** Special District Alternate Commissioner, 2011-2019
- **Independent Special Districts of Orange County (ISDOC) Executive Committee** – Immediate Past President, 2018-2020; President, 2016-2018
- **Mesa Water District** Director, 2009-present; President, 2012-2014
- **Mesa Water District Improvement Corporation** President, 2010-2012 & 2017-2022; Engineering & Operations Committee Chairman; Legislative & Public Affairs Committee Vice Chairman
- **Association of California Water Agencies (ACWA)** Local Government Committee, 2016-2019, 2022-present
- **County of Orange Housing & Community Development Commission** – Vice Chair, 2019-2021; Commissioner 2017-2021 (appointed by the Orange County Board of Supervisors)
- **City of Costa Mesa**
 - Planning Commissioner & Vice Chairman, 2004-2009
 - Parks & Recreation Commissioner, 2002-2004
 - Finance Committee, 2014-2017; Finance Committee Chairman, 2016-2017; Finance & Pension Advisory Committee Chairman, 2017-2020
 - Residential Rehabilitation & Redevelopment Committee, 1999-2009
 - Citizen’s Police Academy graduate; Neighbors for Neighbors volunteer
- **Costa Mesa Chamber of Commerce** Board Member, 2017-present
- **Costa Mesa Senior Center** Board Member
- **Friends of Costa Mesa Libraries** Board Member

As your advocate at OC LAFCO over the past 12+ years, James R. Fisler (Jim) has been a strong leader and voice for Special Districts. Committed to promoting outstanding customer service, and to the efficient delivery of government services, Commissioner Fisler is grateful to have served as your representative at both OC LAFCO and ISDOC, where he reduced member dues by 75 percent.

With a passion for public policy and community service, Commissioner Fisler prioritizes protecting local control and representing the interests of Orange County’s water, stormwater, sanitary, sewer, cemetery, library, vector control, recreation and parks, and community services districts.

Commissioner Fisler is a Broker/Associate with Torelli Realty in Costa Mesa and a Mortgage Loan Officer with CB Loans in Redondo Beach. Prior to that, he was a Southern California regional manager for Nordstrom for over 12 years.

Joe Muller for LAFCO

Special District Representative



It is an honor to put my name forward as a candidate for Special District Representative to the Orange County Local Agency Formation Commission (OC LAFCO), and I would respectfully ask for your district's support of me for this position.

LAFCO is currently in the midst of its planned schedule of countywide Municipal Service Reviews, and as such it is critical that the participation of the Special District representatives on the Commission are closely involved in this process to ensure fair and effective representation of our 26 agencies.

My diversified background in public service has equipped me with the unique perspective and experience that makes me ideally suited to serve on OC LAFCO. I was elected to the Dana Point City Council in 2014 and twice served as Mayor during my Council tenure prior to terming out in 2022, at which time I ran for and was elected to the South Coast Water District Board.

My contributions extend to various regional boards, including:

- Orange County Transportation Authority Board of Directors (where I chaired the Regional Planning and Highways Committee)
- Foothill/Eastern Transportation Corridor Agency (TCA) – Vice Chair, 2022
- LOSSAN Rail Corridor Agency Board of Directors
- Orange County Fire Authority Board of Directors – Chair, 2022; Vice Chair, 2021
- Orange County Parks Commission – Chair, 2021

In addition, I have been a representative to the League of California Cities, Orange County Council of Governments, South Orange County Association of Mayors, Association of California Cities-Orange County, and Orange County City Selection Committee.

These experiences complement my private sector insights, gained initially as an Environmental Chemist and later in sales, where I enhanced supply chains, contributed to educational advancements, and managed family-owned property investments.

Your support is invaluable to me, and I am keen to advocate on behalf of your district on OC LAFCO. Thank you for considering my candidacy to represent Orange County's Special Districts.



BALLOT

REGULAR SPECIAL DISTRICT MEMBER

Orange County Local Agency Formation Commission (OC LAFCO)

Term of Office Expires 06/30/2028

Midway City Sanitary District

Name of District

Certification of Voting Member

I, Mark Nguyen, hereby certify that I am (***select one***):
Board Member

- the presiding officer of the above-named district.
- a member of the Board of the above-named district designated to vote in the absence of the presiding officer pursuant to G.C. §56332(a). I have submitted proof of this designation to the OC LAFCO Executive Officer.

Signature

Date

CANDIDATES FOR OC LAFCO REGULAR SPECIAL DISTRICT MEMBER:

(Check one only.)

- James R. Fisler, Mesa Water District
- Joe Muller, South Coast Water District
- Abstain

AGENDA ITEM #8B

Date: May 21, 2024
To: Board of Directors
From: Robert Housley, General Manager
Prepared by: Milo Ebrahimi, P.E., District Engineer
Subject: Resolution No. 2024-10

A RESOLUTION OF THE BOARD OF DIRECTORS OF THE MIDWAY CITY SANITARY DISTRICT OF ORANGE COUNTY (1) RATIFYING AND AUTHORIZING CONTINUED EMERGENCY ACTION FOR THE REPAIR, REPLACEMENT, AND LINING OF DAMAGED SEWER LINES, REMOVAL AND REPLACEMENT OF A MANHOLE, AND RELATED STREET REPAIRS IN WEBBER PLACE BETWEEN MANHOLE 2006 AND MANHOLE 2005 AND IN PEMBROOK LANE BETWEEN MANHOLE 2006 AND MANHOLE 2019; (2) RATIFYING AN AGREEMENT WITH PAULUS ENGINEERING, INC. AND RELATED CHANGE ORDER FOR A PORTION OF THE WORK; (3) APPROVING AND AUTHORIZING THE GENERAL MANAGER TO EXECUTE AN AGREEMENT WITH PERFORMANCE PIPELINE TECHNOLOGIES, INC. FOR A PORTION OF THE WORK; AND (4) FINDING THAT THE PROJECT IS STATUTORILY EXEMPT FROM REVIEW UNDER THE CALIFORNIA ENVIRONMENTAL QUALITY ACT

BACKGROUND

Midway City Sanitary District (District)'s sewer system is aging. Because of the aging of the District's sewer system, there will be a need for immediate attention and remediation in some areas at times.

The City of Westminster (City) discovered a settlement at the intersection of Webber Place and Pembroke Lane in the course of performing a survey for an upcoming Street Improvement Project. The sewer system in this area (Tract No. 1961) was built in the 1950's, and the sewer lines are approximately 70 years old and are not lined. Immediately after the report by the City, District staff started an investigation to see if the damage to the street is related to the public sewer. District asked Empire Pipeline and Equipment to perform emergency CCTV inspection of the sewer mains in Webber Place and Pembroke Lane. After checking the CCTV videos of the sewer lines, the District Engineer observed a broken pipe in Webber Place a few feet north of the manhole at the intersection and cracks in the sewer pipes in Pembroke Lane a few feet east of the manhole, directly under the settlement area at the intersection. Photos of the damaged facilities are attached to this Report (Attachment 1).

District Staff determined these sewer line segments are at risk of collapse due to their deteriorated condition, which would likely result in a sewer spill and interruption of sewer service in the area.

Further subsidence is also possible, creating a potential safety hazard to vehicular traffic at this intersection if the sewer lines are not expeditiously repaired.

In addition, the City is planning to grind and pave Pembroke Lane and Webber Place above the impacted sewers beginning on June 3, 2024, as part of its scheduled Street Improvement Project. Operation of heavy equipment during the Street Improvement Project risks further damage to the sewer lines due to their poor condition, and due to the nature of the City's agreement and type of project funding, the City is not able to postpone or change the date of the project. If the sewer repairs were to be performed after completion of the City's project, the two streets would need to be completely repaved per City requirements.

Under ordinary circumstances, public works contracts over \$15,000 require the District to follow the public bidding process set forth in the Public Contract Code and the District's Purchasing Policies and Procedures. However, in the event of an emergency, Public Contract Code sections 20806 and 22050 authorize the Board of Directors, by 4/5 vote of its members, to award a contract for a public work over \$15,000 without complying with the public works competitive bidding requirements set forth in the Public Contract Code, or to authorize an employee to do so. The Board has delegated authority to the General Manager to enter into emergency public works contracts pursuant to the District's Purchasing Policies and Procedures, which was adopted by the required 4/5 vote of the Board unanimous vote of the Board on April 4, 2023, pursuant to Resolution No. 2023-09.

Section 10.B.11 of the District's Purchasing Policies and Procedures provides as follows:

In the event of an emergency as defined in Public Contract Code section 1102 as "a sudden, unexpected occurrence that poses a clear and imminent danger, requiring immediate action to prevent or mitigate the loss or impairment of life, health, property, or essential public services" or as described in Public Contract Code section 20806 as "work to prepare for national or local defense", the District may enter into a Contract for the construction of a Public Works Project through Negotiated Procurement if the Board of Directors adopts findings by a four-fifths vote of its members declaring that the public interest and necessity demand the immediate expenditure of District funds to safeguard life, health, or property. In the event the Board of Directors is unavailable in an emergency, as defined in this paragraph, the General Manager is authorized to enter into a Contract for the repair or replacement of a public facility, take any directly related and immediate action required by that emergency, and procure the necessary equipment, services, and supplies for those purposes, without following the District's procurement procedures set forth herein, including competitive bidding procedures and/or obtaining contracting approval as otherwise normally required. The District shall comply with the requirements set forth in Public Contract Code section 20806 and Public Contract Code sections 22050 et seq., for specified emergencies.

On or about May 9, 2024, pursuant to Sections 3 and 10.B.11 of the District's Purchasing Policy and Procedures, the General Manager executed an Agreement on behalf of the District for Emergency Sewer Repairs with Paulus Engineering, Inc. ("Paulus") for the emergency repair and

replacement of 20 linear feet of the damaged sewer mains, removal and replacement of the adjacent manhole, and related improvements to restore the street to its previous condition. Under this Agreement, Paulus has agreed to perform the repair work for \$103,231.00, plus the cost of bonds and any additional unanticipated groundwater removal work. Paulus commenced excavation of the area on May 13th, but encountered significant groundwater that needs to be removed. On May 14, 2024, the General Manager approved a change order in the amount of \$7,475.00, and Paulus recommenced work on May 15th.

Once Paulus completes this work, approximately 620 linear feet of the sewer line in Webber Place between Manhole 2006 and Manhole 2005 and in Pembroke Lane between Manhole 2006 and Manhole 2019 will need to be lined to prevent further deterioration and prevent possible collapse. District Staff obtained a proposal from Performance Pipeline Technologies, Inc. to perform the sewer lining portion of the Project and has prepared plans, specifications, and a proposed agreement for the Board's consideration.

DISCUSSION

When the General Manager takes emergency action pursuant to repair a public facility under his delegated authority, Public Contract Code Section 22050 requires the General Manager to report to the Board at its next regular meeting the reasons justifying why the emergency will not permit a delay resulting from a competitive solicitation for bids and why the action is necessary to respond to the emergency. Section 22050 further requires that the Board review the need to continue any emergency action taken by the Board or the General Manager at every regular meeting until the emergency action is terminated and either adopt a resolution **by 4/5 vote** finding that there is a need to continue the emergency action or terminate the emergency action and direct that a contract or contracts for further repair work be procured in accordance with standard competitive procurement procedures. Under Section 2050, the Board is required to terminate the action at the earliest possible date that conditions warrant so that the remainder of the emergency action may be completed by giving notice for bids to let contracts.

In this case, immediate action was needed to address the emergency as soon as possible and without undertaking a competitive solicitation for bids in order to restore the integrity of the street for the protection of the public and to prevent and mitigate the potential for a sewer spill and interruption of sewer service due to the collapse of the sewer lines. This work has commenced and is still ongoing. Staff anticipates the Project will be completed by May 31, 2024. Therefore, Staff is requesting that the Board find by 4/5 vote that there is a need to continue the emergency action for the repair, replacement, and lining of damaged sewer mains, removal and replacement of a manhole, and related street repairs in Webber Place between Manhole 2006 and Manhole 2005 and in Pembroke Lane between Manhole 2006 and Manhole 2019. A proposed Resolution with the required findings to continue the emergency action has been prepared for the Board's consideration (Attachment 2).

As part of the proposed Resolution, Staff is also asking the Board to ratify the Agreement with Paulus Engineering, Inc. (Attachment 3) and the subsequent Change Order (Attachment 4) entered into by the General Manager under his emergency authority. The majority of the Project is being completed by Paulus. Paulus will perform manhole replacement due to manhole settlement, spot

sewer pipe replacement due to cracks and broken sewer pipe, and remediation of the street settlement due to the damaged public sewer mains.

Once Paulus's work is completed, the replaced sewer line segments will need to immediately be lined to prevent soil infiltration into the pipes through the cracks and so that further emergency spot repairs to the pipe due to the age and condition of the pipe will not be needed. The existing sewer pipe is 70 years of age. The rehabilitation of these lines will give an additional 50 years of service. The District has obtained a proposal for this work from Performance Pipeline Technologies, Inc. to perform this work for a lump sum price of \$39,760.00, plus the cost of required permits and bonds. General Counsel has prepared a contract with Performance Pipeline Technologies, Inc. (Attachment 5) for the Board's consideration. As part of the proposed Resolution, Staff is asking the Board to approve the contract in substantially the same form as presented and authorize the General Manager to make minor changes as necessary and to execute the Agreement on behalf of the District. It is anticipated that the lining of two sewer line segments will take approximately one day to complete once the work commences.

FISCAL IMPACT

The fiscal impact for this project will be as follows:

1. Repair and replacement of 20 linear feet of damaged sewer lines, removal and replacement of a manhole, groundwater removal, and related street repairs: \$110,706.00.
2. Lining of 620 linear feet of sewer line in Webber Pl between manhole 2006 and manhole 2005 and in Pembroke Ln between manhole 2006 and manhole 2019: \$39,760.00.
3. The cost of surety bonds, required permits, and other reimbursables: \$5,000-\$10,000.

Total fiscal impact is estimated to be approximately \$155,000 to \$160,000 from Sewer Emergency Repairs Account, Account Number 7700.90.

STAFF RECOMMENDATION

Staff recommends that the Board of Director adopt proposed Resolution No. 2024-10 by a 4/5 vote of its members (1) ratifying and authorizing continued emergency action for the repair, replacement, and lining of damaged sewer lines, removal and replacement of a manhole, and related street repairs in Webber Place between Manhole 2006 and Manhole 2005 and in Pembroke Lane between Manhole 2006 and Manhole 2019; (2) ratifying an agreement and change order with Paulus Engineering, Inc. for a portion of the work; (3) approving and authorizing the General Manager to execute an agreement with Performance Pipeline Technologies, Inc. for a portion of the work; and (4) finding that the Project is exempt from the California Environmental Quality Act.

ATTACHMENTS:

1. Photos of Damaged Facilities
2. Proposed Resolution 2024-10
3. Agreement with Paulus Engineering, Inc. for Emergency Sewer Repairs dated May 7, 2024

4. Change Order No. 1 with Paulus Engineering, Inc.
5. Proposed Agreement with Performance Pipeline Technologies, Inc. for Emergency Sewer Lining Repairs

Photo #1 - 04/10/2024 – CCTV photo of a damaged pipe a few feet north of manhole number 2006



Photo #2 - 04/10/2024 – CCTV photo of a damaged pipe a few feet east of manhole number 2006



Photo #3 - 04/24/2024 – subside street and subside manhole number 2006 at the intersection of Pembroke Lane and Webber Place (looking north)



Photo #4 - 04/24/2024 – subsidence street and subsidence manhole number 2006 at the intersection of Pembroke Lane and Webber Place (looking south)



Photo #5 – 05/13/2024 – condition of the broken sewer pipe after excavation



Photo #6 – 05/14/2024 – ground water issue after excavation



RESOLUTION NO. 2024-10

A RESOLUTION OF THE BOARD OF DIRECTORS OF THE MIDWAY CITY SANITARY DISTRICT OF ORANGE COUNTY (1) RATIFYING AND AUTHORIZING CONTINUED EMERGENCY ACTION FOR THE REPAIR, REPLACEMENT, AND LINING OF DAMAGED SEWER LINES, REMOVAL AND REPLACEMENT OF A MANHOLE, AND RELATED STREET REPAIRS IN WEBBER PLACE BETWEEN MANHOLE 2006 AND MANHOLE 2005 AND IN PEMBROOK LANE BETWEEN MANHOLE 2006 AND MANHOLE 2019; (2) RATIFYING AN AGREEMENT WITH PAULUS ENGINEERING, INC. AND RELATED CHANGE ORDER FOR A PORTION OF THE WORK; (3) APPROVING AND AUTHORIZING THE GENERAL MANAGER TO EXECUTE AN AGREEMENT WITH PERFORMANCE PIPELINE TECHNOLOGIES, INC. FOR A PORTION OF THE WORK; AND (4) FINDING THAT THE PROJECT IS STATUTORILY EXEMPT FROM REVIEW UNDER THE CALIFORNIA ENVIRONMENTAL QUALITY ACT

The Board of Directors of the Midway City Sanitary District hereby finds, determines, declares, and resolves as follows:

WHEREAS, District Staff has advised the Midway City Sanitary District Board of Directors of the need for the emergency repair, replacement, and lining of damaged sewer mains, removal and replacement of a manhole, and related street repairs in Webber Place between Manhole 2006 and Manhole 2005 and in Pembrook Lane between Manhole 2006 and Manhole 2019 (the "Project"), constituting an unexpected emergency that poses a clear and imminent danger, requiring immediate action to prevent or mitigate the loss or impairment of health, property and/or essential sewer services; and

WHEREAS, pursuant to Public Contract Code sections 20806 and 22050 and Section 10.B.11 of the District's Purchasing Policy and Procedures, in the event of an emergency, the Board of Directors or the General Manager may award a contract for a public work over \$15,000 without complying with the public works competitive bidding requirements set forth in the Public Contract Code and the District's Purchasing Policies and Procedures; and

WHEREAS, on or about May 9, 2024, pursuant to Sections 3 and 10.B.11 of the District's Purchasing Policy and Procedures the General Manager entered

into an Agreement on behalf of the District for Emergency Sewer Repairs with Paulus Engineering, Inc., dated May 7, 2024, for the emergency repair and replacement of the damaged sewer mains, removal and replacement of a manhole, and related street improvements; and

WHEREAS, pursuant to the terms of said Agreement, on May 14, 2024, the General Manager approved a Request for Change Order from Paulus Engineering for additional work to cover pumping groundwater from the excavation and disposing of it at the approved Orange County Sanitation District site; and

WHEREAS, the Board has been presented with a proposed Agreement for Emergency Sewer Lining Repairs between the District and Performance Pipeline, Technologies, Inc. for CIPP lining of the sewer main segments in Webber Place between Manhole 2006 and Manhole 2005 and in Pembroke Lane between Manhole 2006 and Manhole 2019; and

WHEREAS, the Board of Directors reviewed the emergency action, Agreement with Paulus Engineering, Inc. and proposed Agreement with Performance Pipeline Technologies, Inc. at its regular meeting of May 21, 2024, and received a report from the General Manager and District Engineer indicating a need to continue the Project.

NOW, THEREFORE, THE BOARD OF DIRECTORS OF THE MIDWAY CITY SANITARY DISTRICT DOES HEREBY RESOLVE, DETERMINE, AND ORDER AS FOLLOWS:

Section 1. The Board finds, based on substantial evidence presented at its meeting of May 21, 2024, that (a) there is a continuing need for the emergency repair, replacement, and lining of damaged sewer mains, removal and replacement of a manhole, and related street repairs in Webber Place between Manhole 2006 and Manhole 2005 and in Pembroke Lane between Manhole 2006 and Manhole 2019, which constitutes an unexpected emergency that poses a clear and imminent danger, requiring immediate action to prevent or mitigate the loss or impairment of life, health, property and/or essential sewer services; (b) the emergency will not permit a delay resulting from a competitive solicitation for bids; (c) immediate repairs are necessary to respond to the emergency; and (d) that the public interest and necessity demand immediate expenditures of funds to safeguard life, health or property.

Section 2. The Board ratifies the action regarding the emergency taken by the General Manager.

Section 3. The Board finds a need to continue proceeding with the emergency repair of the damaged sewer main located in Webber Place and Pembroke Lane.

Section 4. The Board ratifies the Agreement for Emergency Sewer Repairs with Paulus Engineering, Inc., dated May 7, 2024, entered into by the General Manager on behalf of the District for the emergency repair of the damaged sewer mains, and the Change Order to said Agreement entered into by the General Manager on May 14, 2024.

Section 5. The Board approves the Agreement for Emergency Sewer Lining Repairs between the District and Performance Pipeline Technologies, Inc. in substantially the same form as presented at the May 21, 2024 meeting and authorizes the General Manager to make minor modifications to the Agreement as needed and to execute the Agreement on behalf of the District.

Section 6. The Board finds that the Project is statutorily exempt from review under the California Environmental Quality Act (CEQA) pursuant to Public Resources Code sections 21080(b)(2) and 21080(b)(4).

Section 7. This Resolution shall take effect immediately upon adoption.

PASSED AND ADOPTED, at a regular meeting of the Board of Directors of Midway City Sanitary District of Orange County, California, held this 21st day of May, 2024.

Mark Nguyen, President

ATTEST:

Andrew Nguyen, Secretary

CERTIFICATION

I, Andrew Nguyen, Secretary of the MIDWAY CITY SANITARY DISTRICT of Orange County, California, do hereby certify that the foregoing Resolution No. 2024-10 was duly adopted at a meeting of the Governing Board of said District held on the 21st day of May, 2024 by the following vote of the members of the Board:

AYES:
NOES:
ABSENT:

and I further certify that Mark Nguyen, as President, and Andrew Nguyen, as Secretary, signed and approved said Resolution No. 2024-10 on the 21st day of May, 2024.

Andrew Nguyen, Secretary

(District Seal)

STATE OF CALIFORNIA)
) ss.
COUNTY OF ORANGE)

I, Andrew Nguyen, Secretary of the Midway City Sanitary District of Orange County, California, do hereby certify that the foregoing is a full, true and correct copy of Resolution No. 2024-10 passed and adopted by the Board of Directors of said District at a meeting thereof held on the 21st day of May, 2024.

IN WITNESS WHEREOF, I have hereunto set my hand and affixed my official Seal of said District this 21st day of May, 2024.

Andrew Nguyen, Secretary

AGREEMENT FOR EMERGENCY SEWER REPAIRS

*Paulus Engineering, Inc.
(Emergency Sewer Main Repair in Webber Place and Pembroke Lane)*

THIS AGREEMENT FOR EMERGENCY SEWER REPAIRS (hereinafter “Agreement” or “Contract”) is made this 7th day of May, 2024, by the MIDWAY CITY SANITARY DISTRICT, a public entity (hereinafter referred to as “DISTRICT”) and PAULUS ENGINEERING, INC., a California corporation, (hereinafter referred to as “CONTRACTOR”). DISTRICT and CONTRACTOR are sometimes hereinafter individually referred to as “Party” and are hereinafter collectively referred to as the “Parties.”

RECITALS

The following recitals are a substantive part of this Agreement:

- A. This Agreement is entered into pursuant to Resolution No. 2023-09 adopted by the Midway City Sanitary District Board of Directors on April 4, 2023, and Public Contract Code Sections 20806 and 22050.
- B. DISTRICT has determined there is a need to retain the services of a qualified contractor to perform emergency sewer main repairs in Webber Place between Manhole 2006 and Manhole 2005 and in Pembroke Lane between Manhole 2006 and Manhole 2019 (the “Project”).
- C. CONTRACTOR has submitted to DISTRICT a proposal, dated May 2, 2024, to complete the PROJECT (the “Proposal”).
- D. CONTRACTOR represents and maintains that it is ready, willing, and able to perform the emergency sewer repairs required as specified in Sections 1 and 2 of this Agreement and in accordance with the terms and conditions of this Agreement and under the direction of the District’s Engineer.
- E. DISTRICT desires to retain CONTRACTOR to complete the Project.

AGREEMENT

THE PARTIES MUTUALLY AGREE AS FOLLOWS:

1. Scope of Work and General Conditions.

1.1 Scope of Work. In compliance with all terms and conditions of this Agreement, CONTRACTOR shall furnish, under the conditions expressed in the Plans and Specifications, at its own expense, all tools, equipment, materials and supplies and shall perform all labor necessary to complete the Project in good workmanlike and substantial order (hereinafter referred to as the “Scope of Work,” the “Services” or “Work”). “Project” shall mean the work to be performed under

the “Contract Documents,” as defined below. All Work or Services shall be completed to the reasonable satisfaction of DISTRICT.

1.2 Contract Documents. The Agreement between the Parties shall consist of the “Contract Documents,” which shall consist of following: (1) this Agreement (also referred to as the “Contract”); (2) CONTRACTOR’S Proposal attached hereto at Exhibit A; (3) the Plans and Specifications attached hereto at Exhibit B; and (4) the General Conditions attached hereto at Exhibit C. Each of the Contract Documents is hereby incorporated by reference into this Agreement with the same force and effect as if the same were set forth at length herein. All provisions of the Contract Documents shall be binding on the Parties. Should any conflict or inconsistency exist in the Contract Documents, the conflict or inconsistency shall be resolved by applying the provisions in the highest priority document, which shall be determined in the following order of priority: (1st) the terms and conditions of this Agreement; (2nd) the terms and provisions of the Plans and Specifications (Exhibit B); (3rd) the terms and provisions of the General Conditions (Exhibit C); and (4th) the provisions of the CONTRACTOR’s Proposal (Exhibit A).

1.3 Compliance with Law. CONTRACTOR shall comply at all times during the term of this Agreement with all applicable laws, ordinances, codes, and regulations of the federal, state, and local government, including without limitation all applicable fair labor standards and Cal/OSHA requirements. CONTRACTOR shall keep itself fully informed of and in compliance with all local, state, and federal laws, rules, and regulations in any manner affecting the performance of the Work and Services, including all Cal/OSHA requirements, and shall give all notices required by law. CONTRACTOR shall be liable for all violations of such laws and regulations in connection with performing the Work and Services. If CONTRACTOR performs any Work or Services in violation of such laws, rules, and regulations, CONTRACTOR shall be solely responsible for all penalties and costs arising therefrom. CONTRACTOR shall defend, indemnify, and hold DISTRICT, its officials, officers, employees, agents and volunteers, free and harmless from any claim or liability arising out of any failure or alleged failure to comply with such laws, rules, or regulations.

1.4 Licenses, Permits, and Fees. Prior to performing any Services or Work hereunder CONTRACTOR shall obtain all licenses, permits, qualifications, and approvals of whatever nature that are legally required to practice its profession and perform the Work and Services required by this Agreement. CONTRACTOR represents and warrants to DISTRICT that CONTRACTOR shall, at its sole cost and expense, keep in effect at all times during the term of this Agreement and any extension, any license, permit, qualification, or approval that is legally required for CONTRACTOR to perform the Work and Services under this Agreement. CONTRACTOR further represents and warrants to DISTRICT that CONTRACTOR is in good standing and authorized to do business in California and the local jurisdiction(s) comprising the site for the Work and is properly registered with the California Secretary of State pursuant to applicable law. CONTRACTOR shall have the sole obligation to pay for any fees, assessments, and taxes, plus applicable penalties and interest, which may be imposed by law and arise from or are necessary for the CONTRACTOR’s performance of the Work and Services required by this Agreement, and shall defend, indemnify, and hold DISTRICT, its officials, officers, employees, agents and volunteers, free and harmless from and against any claim or liability arising out of any failure or

alleged failure to obtain such license, permits, and approvals of whatever nature that are legally required to perform the Work or Services.

1.5 Familiarity with Work. By executing this Agreement, CONTRACTOR warrants that: (1) it is fully familiar with all the terms, conditions, and obligations of the Contract Documents; (2) it has thoroughly investigated and considered the Scope of Work or Services to be performed; (3) it has carefully considered how the Services or Work should be performed and has carefully examined the location or locations at or with respect to where such Services or Work is to be performed and is aware of all conditions there; and (4) it understands the facilities, difficulties, and restrictions of attending performance of the Services or Work under this Agreement. If the Services or Work involve work upon any site, CONTRACTOR represents and maintains that CONTRACTOR has or will investigate the site and is or will be fully acquainted with the conditions there existing, prior to commencement of any Services or Work hereunder. Should CONTRACTOR discover any latent or unknown conditions materially differing from those inherent in the Work or as represented by DISTRICT, it shall immediately inform DISTRICT of this and shall not proceed, except at CONTRACTOR's risk, until written instructions are received from DISTRICT.

1.6 Care of Work. CONTRACTOR shall adopt reasonable methods during the term of the Agreement to furnish continuous protection to the Work and the equipment, materials, papers, documents, plans, studies, and/or other components thereof to prevent losses or damages, and shall be responsible for all such damages, to persons or property, until acceptance of the Work by DISTRICT, except such losses or damages as may be caused by DISTRICT's own negligence.

1.7 Stop Notices. In the event DISTRICT receives a stop notice from any laborer or material supplier alleging non-payment by CONTRACTOR, DISTRICT shall be entitled to deduct all of its costs and expenses incurred relating thereto, including but not limited to administrative and legal fees.

1.8 Further Responsibilities of Parties. Both Parties agree to use reasonable care and diligence to perform their respective obligations under this Agreement. Both Parties agree to act in good faith to execute all instruments, prepare all documents, and take all actions as may be reasonably necessary to carry out the purposes of this Agreement.

2. Time of Commencement and Completion.

2.1 Schedule of Performance. CONTRACTOR shall commence the Services pursuant to this Agreement upon receipt of a written notice to proceed from DISTRICT's Engineer and shall perform all Services within the time period(s) established in the Schedule of Performance set forth in the Plans and Specifications (Exhibit B), or otherwise mutually agreed upon by the Parties. When requested by CONTRACTOR, extensions to the time period(s) specified in the Schedule of Performance may be approved in writing by the DISTRICT; however, the DISTRICT shall not be obligated to grant such an extension.

2.2 Time of Essence. Time is of the essence in the performance of this Agreement. The time for commencement and completion of the Work to be performed by CONTRACTOR is

an essential condition of this Agreement. CONTRACTOR shall prosecute regularly and diligently the Work according to the agreed upon Schedule of Performance.

3. Contract Price and Method of Payment.

3.1 Contract Price. DISTRICT agrees to pay and CONTRACTOR agrees to accept as full consideration for the faithful performance of this Agreement, subject to any subsequent additions or deductions as provided below and/or in approved change orders, the lump sum of ONE HUNDRED THREE THOUSAND TWO HUNDRED THIRTY ONE DOLLARS and 00/100 CENTS (\$103,231.00), which includes all “Inclusions” and soils testing as itemized on CONTRACTOR’s Proposal (Exhibit A) (the “Contract Price”). DISTRICT further agrees to compensate CONTRACTOR for all additional repair Work required by DISTRICT’S Engineer at the rate of NINETY-THREE DOLLARS (\$93.00) per square foot as specified in CONTRACTOR’s Proposal and for all work and services required to dewater groundwater, if encountered, on a time and materials basis, which costs, if any, shall be added to the Contract Price. The Contract Price shall include the attendance of CONTRACTOR at all Project meetings deemed reasonably necessary by the DISTRICT. CONTRACTOR shall not be entitled to any increase in the Contract Price for attending these meetings. In addition to payment of the Contract Price, DISTRICT agrees to reimburse CONTRACTOR for the actual cost of any bonds, permits, and/or other items specified in CONTRACTOR’s Proposal as excluded from the Contract Price.

3.2 Payment. Prior to the twentieth (20th) day of the month next following the commencement of the Work, there shall be paid to CONTRACTOR a sum equal to ninety-five percent (95%) of the value of the actual Work completed as determined by DISTRICT; and thereafter, prior to the twentieth (20th) day of each successive month as the work progresses, CONTRACTOR shall be paid such sum as will bring the total payments received, since the commencement of the Work as determined by the DISTRICT (less all previous payments) to ninety-five percent (95%) of the value of the actual Work completed, provided that CONTRACTOR submits its request for payment prior to the last day of the preceding month. Partial payments on the Contract Price shall not be considered as an acceptance of any part of the Work. Pursuant to Public Contract Code Section 22300, CONTRACTOR will be permitted to substitute securities for any monies withheld by DISTRICT to ensure performance of the Agreement.

3.3 Changes in Contract Price. Any changes to the Contract Price shall be pursuant to written change order approved by the DISTRICT as set forth in the General Conditions (Exhibit C).

3.4 Termination. If termination of this Agreement for default or convenience is effected by the DISTRICT in accordance with paragraphs (a) or (b) of Section 11, an equitable adjustment in the Contract Price shall be made, but (1) no amount shall be allowed for anticipated profit on unperformed services or other work, and (2) any payment due to the CONTRACTOR at the time of termination may be adjusted to cover any additional costs to the DISTRICT because of the CONTRACTOR’s default. If termination for default is effected by the CONTRACTOR in accordance with paragraph (a) of Section 11, the equitable adjustment shall include a reasonable profit for services or other work performed, but no adjustment will be allowed for anticipated

profits. The equitable adjustment for any termination shall provide for payment to the CONTRACTOR for services rendered and expenses incurred prior to the termination, in addition to termination settlement costs reasonably incurred by the CONTRACTOR relating to commitments which had become firm prior to the termination.

4. Completion. Within ten (10) days after the completion date of the Project, CONTRACTOR shall file with the DISTRICT's Engineer its affidavit stating that all workers and persons have been paid in full, and that there are no claims outstanding against the Project for either labor or material, except those certain items, if any, to be set forth in affidavit covering disputed claims, or items in connection with Stop Notices which have been filed under the provisions of the statutes of the State of California. DISTRICT may require affidavits or certificates of payment and/or releases from any subcontractor, laborer or material supplier.

5. Warranty.

(a) CONTRACTOR agrees to perform all Work under this Agreement in accordance with the Plans and Specifications.

(b) CONTRACTOR guarantees for a period of at least one (1) year from the date of completion of the Work that the completed work is free from all defects due to faulty materials, equipment or workmanship and that it shall promptly make whatever adjustments or corrections may be necessary to cure any defects, including repairs of any damage to other parts of the Project resulting from such defects. DISTRICT shall promptly give notice to CONTRACTOR of observed defects. In the event that CONTRACTOR fails to make adjustments, repairs, corrections or undertake other work made necessary by such defects, DISTRICT may do so and charge CONTRACTOR the cost incurred. The Performance Bond shall remain in full force and effect through the guarantee period.

(c) CONTRACTOR's obligations under this clause are in addition to CONTRACTOR's other express or implied assurances under this Agreement or state law and in no way diminish any other faulty materials, equipment or work.

6. Prevailing wages. DISTRICT has determined that the Work and Services under this Agreement requires work of labor categories which are subject to Prevailing Wage Laws identified in the State of California Labor Code. CONTRACTOR is aware of the requirements of California Labor Code Section 1720, et seq., and 1770, et seq., as well as California Code of Regulations, Title 8, Section 16000, et seq., ("Prevailing Wage Laws"), which require the payment of prevailing wage rates and the performance of other requirements on "public works" and "maintenance" projects. CONTRACTOR agrees to fully comply with all applicable federal and state labor laws (including, without limitation, the Prevailing Wage Laws). It is agreed by the Parties that, in connection with the Work or Services provided pursuant to this Agreement, CONTRACTOR shall bear all risks of payment or non-payment of prevailing wages under California law, and Consultant hereby agrees to defend, indemnify, and hold DISTRICT, its elected officials, officers, employees, and agents free and harmless from any claim or liability arising out of any failure or alleged failure to comply with the Prevailing Wage Laws. The foregoing indemnity shall survive termination of

this Agreement CONTRACTOR understands and agrees to comply with the following California Labor Code compliance conditions [Labor Code Sections 1720 et seq., 1813, 1860, 1861, 3700]:

(a) This Agreement is subject to the provisions of Division 2, Part 7, Chapter 1 (commencing with Section 1720) of the California Labor Code relating to public works and the awarding public agency (“DISTRICT”) and CONTRACTOR agrees to be bound by all the provisions thereof as though set forth in full herein.

(b) CONTRACTOR shall be registered with the Department of Industrial Relations (“DIR”) in accordance with California Labor Code Section 1725.5 and has provided proof of registration to DISTRICT prior to the Effective Date of this Agreement.

(c) CONTRACTOR agrees to comply with the provisions of California Labor Code Sections 1771, 1774 and 1775 concerning the payment of prevailing rates of wages to workers and the penalties for failure to pay prevailing wages. The applicable prevailing wage determination(s) may be obtained at <https://www.dir.ca.gov/oprl/dprevwagedetermination.htm>, are on file with DISTRICT, and are available to any interested party upon request. A copy of said rates shall be posted at each job site during the Term of this Agreement.

(d) Pursuant to California Labor Code Section 1771.4, CONTRACTOR’s services are subject to compliance monitoring and enforcement by the Department of Industrial Relations. CONTRACTOR shall post job site notices as prescribed by DIR regulations and furnish the records specified in California Labor Code Section 1776 directly to the Labor Commissioner in the manner prescribed by California Labor Code Section 1771.4(a)(3) and (c)(2).

(e) CONTRACTOR shall comply with the provisions of California Labor Code Section 1776 which, among other things, require Contractor and each subcontractor to (1) keep accurate payroll records, (2) certify and make such payroll records available for inspection as provided by Section 1776, and (3) inform the DISTRICT of the location of the records. CONTRACTOR is responsible for compliance with Section 1776 by itself and all of its subcontractors.

(f) CONTRACTOR shall comply with the provisions of California Labor Code Section 1777.5 concerning the employment of apprentices on public works projects, and further agrees that CONTRACTOR is responsible for compliance with Section 1777.5 by itself and all of its subcontractors.

(g) Eight (8) hours of labor shall constitute a legal day’s work for all workmen employed in the execution of this Agreement, and CONTRACTOR and any subcontractor shall comply with and be governed by the laws of the State of California having to do with working hours set forth in Division 2, Part 7, Chapter 1, Article 3 of the California Labor Code. CONTRACTOR shall comply with the provisions of California Labor Code Section 1813 concerning penalties for workers who work excess hours. CONTRACTOR shall, as a penalty to DISTRICT, forfeit twenty-five dollars (\$25) for each worker employed in the execution of this Agreement by the CONTRACTOR or by any subcontractor for each calendar day during which such worker is required or permitted to work more than eight (8) hours in any one calendar day

and forty (40) hours in any one calendar week in violation of the provisions of Division 2, Part 7, Chapter 1, Article 3 of the California Labor Code. (See, e.g., Cal. Labor Code §1815.)

(h) Pursuant to California Labor Code Sections 1860 and 3700, CONTRACTOR will be required to secure the payment of compensation to its employees. By signing this Agreement, CONTRACTOR hereby certifies as follows:

“I am aware of the provisions of Section 3700 of the Labor Code which require every employer to be insured against liability for workers’ compensation or to undertake self-insurance in accordance with the provisions of that code, and I will comply with such provisions before commencing the performance of the work of this Agreement.”

(i) Pursuant to California Labor Code Section 1771.1, CONTRACTOR and any subcontractor shall not be qualified to bid on, be listed in a bid proposal, subject to the requirements of Section 4104 of the California Public Contract Code, or engage in the performance of any contract for public work on a public works project unless registered with the DIR and qualified to perform public work pursuant to California Labor Code Section 1725.2. It is not a violation of California Labor Code Section 1771.1 for an unregistered contractor to submit a bid that is authorized by California Business and Professions Code Section 7029.1 or by California Public Contract Code Section 10164 or 20103.5, provided the contractor is registered to perform public work pursuant to Section 1725.5 at the time the contract is awarded. CONTRACTOR shall not perform any work under this Agreement with any subcontractor who is ineligible to perform work on the public works project pursuant to Section 1777.1 or 1777.7 of the California Labor Code. By submitting a bid or proposal to DISTRICT, CONTRACTOR is certifying that it has verified that all subcontractors used on this public work project are registered with the DIR in compliance with Labor Code sections 1771.1 and 1725.5, and CONTRACTOR shall provide proof of registration for themselves and all listed subcontractors to DISTRICT upon request.

(j) CONTRACTOR shall provide the list of subcontractors, along with their DIR registration numbers, utilized on this Agreement prior to any Work being performed; and the CONTRACTOR shall provide a complete list of all subcontractors with each invoice. Additionally, CONTRACTOR shall provide DISTRICT with a complete list of all subcontractors utilized on this Agreement within ten working days of the completion of the Work, along with their DIR registration numbers.

7. Limitations Upon Subcontracting and Assignment.

7.1 Subcontracting. Except for those entities disclosed in CONTRACTOR’s Proposal or subsequently approved by the DISTRICT in writing, CONTRACTOR shall not contract with any other entity to perform any portion of the Work without written approval of the DISTRICT. If CONTRACTOR is permitted to subcontract any part of this Agreement, each such subcontractor shall be duly licensed and registered, and CONTRACTOR shall be responsible to DISTRICT for the acts and omissions of its subcontractor as it is for persons directly employed. Nothing contained in this Agreement shall create any contractual relationship between any subcontractor and DISTRICT. All persons engaged in the work will be considered employees of

CONTRACTOR. DISTRICT will deal directly with and will make all payments to CONTRACTOR. CONTRACTOR represents and warrants that it has complied, and will comply, with all applicable provisions the Subletting and Subcontracting Fair Practices Act, Public Contract Code Sections 4100 through 4113, inclusive.

7.2 Assignment. No assignment(s) by the CONTRACTOR of this Agreement or any part hereof, or of funds to be received hereunder, will be recognized by the DISTRICT unless such assignment(s) has(have) had prior written approval and consent of the DISTRICT and the surety.

8. Surety Bonds. If the Contract Price is in excess of \$25,000.00, CONTRACTOR shall, before entering upon the performance of this Agreement, furnish bonds approved by the DISTRICT's General Counsel - one in the amount of one hundred percent (100%) of the Contract Price bid, to guarantee the faithful performance of the work and one year guarantee, and the other in the amount of one hundred percent (100%) of the Contract Price bid to guarantee payment of all claims for labor and materials furnished. This Agreement shall not become effective until such bonds are supplied to and approved by the DISTRICT.

9. Insurance requirements.

9.1 Commencement of Work. CONTRACTOR shall not commence work under this Agreement until all certificates and endorsements have been received and approved by the DISTRICT. All insurance required by this Agreement shall contain a Statement of Obligation on the part of the carrier to notify the DISTRICT of any material change, cancellation, or termination at least thirty (30) days in advance.

9.2 Workers Compensation Insurance. During the duration of this Agreement, CONTRACTOR and all subcontractors shall maintain Workers Compensation Insurance in the amount and type required by law, if applicable.

9.3 Insurance Amounts. CONTRACTOR and all subcontractors shall procure and maintain insurance acceptable to DISTRICT. Unless otherwise agreed or waived in writing by DISTRICT's General Manager, CONTRACTOR and all subcontractors shall maintain the following insurance for the duration of this Agreement:

(a) Commercial general liability in an amount of \$5,000,000.00 per occurrence: **claims made and modified occurrence policies are not acceptable;** Insurance companies must be acceptable to DISTRICT and have a Best's Guide Rating of A- Class VII or better, as approved by the DISTRICT.

(b) Automobile liability in an amount of \$1,000,000.00 combined single limit: **claims made and modified occurrence policies are not acceptable;** Insurance companies must be acceptable to DISTRICT and have a Best's Guide Rating of A- Class VII or better, as approved by the DISTRICT.

An **On-Going and Completed Operations Additional Insured Endorsement** for the policy under section 4.3 (a) shall designate DISTRICT, its officers, officials, employees, agents, and

volunteers as additional insureds for liability arising out of work or operations performed by or on behalf of the CONTRACTOR. CONTRACTOR shall provide to DISTRICT proof of insurance and endorsement forms that conform to DISTRICT's requirements, as approved by the DISTRICT.

An Additional Insured Endorsement for the policy under section 4.3 (b) shall designate DISTRICT, its officers, officials, employees, agents, and volunteers as additional insureds for automobiles, owned, leased, hired, or borrowed by the CONTRACTOR. CONTRACTOR shall provide to DISTRICT proof of insurance and endorsement forms that conform to DISTRICT's requirements, as approved by the DISTRICT.

For any claims related to this Agreement, CONTRACTOR's insurance coverage shall be primary insurance as respect to DISTRICT, its officers, officials, employees, agents, and volunteers. Any insurance or self-insurance maintained by the DISTRICT, its officers, officials, employees, agents, and volunteers shall be excess of the CONTRACTOR's insurance and shall not contribute with it.

If CONTRACTOR maintains higher insurance limits than the minimums shown above, CONTRACTOR shall provide coverage for the higher insurance limits otherwise maintained by the CONTRACTOR.

10. Risk and Indemnification. All work covered by this Agreement done at the Project site or in preparing or delivering materials to the site shall be at the risk of CONTRACTOR alone. CONTRACTOR agrees to save, indemnify and keep DISTRICT, its officers, officials, employees, agents, architects, engineers, and consultants for this Agreement, and all public agencies from whom permits will be obtained, harmless against any and all liability, claims, judgments, costs and demands, including demands arising from injuries or death of persons (CONTRACTOR's employees included) and damage to property, arising directly or indirectly out of the obligations herein undertaken or out of the operations conducted by CONTRACTOR, save and except claims or litigation arising through the active negligence or willful misconduct of DISTRICT, and CONTRACTOR will make good to and reimburse, DISTRICT for any expenditures, including reasonable attorney's fees DISTRICT may incur by reason of such matters, and if requested by DISTRICT, will defend any such suits at the sole cost and expense of CONTRACTOR. This hold harmless agreement shall apply to all liability regardless of whether any insurance policies are applicable. The policy limits do not act as a limitation upon the amount of indemnification to be provided by CONTRACTOR.

11. Termination.

(a) This Agreement may be terminated in whole or in part in writing by either party in the event of substantial failure by the other party to fulfill its obligations under this Agreement through no fault of the terminating party, provided that no termination may be effected unless the other party is given: (1) not less than ten (10) calendar days' written notice (delivered by certified mail, return receipt requested) of intent to terminate, and (2) an opportunity for consultation with the terminating party prior to termination.

(b) This Agreement may be terminated in whole or in part in writing by the DISTRICT for its convenience, provided that the CONTRACTOR is given (1) not less than ten (10) calendar days' notice (delivered by certified mail, return receipt requested) or intent to terminate, and (2) an opportunity for consultation with the DISTRICT prior to termination.

(c) Upon receipt of termination action under paragraph (a) or (b) above, the CONTRACTOR shall (1) promptly discontinue all affected work (unless the notice directs otherwise), and (2) deliver or otherwise make available to the DISTRICT all data, drawings, specifications, reports, estimates, summaries and such other information and materials as may have been accumulated by the CONTRACTOR in performing this Agreement whether completed or in process.

(d) Upon termination under paragraphs (a) or (b) above, the DISTRICT may take over the work and may award another party an agreement to complete the work under this Agreement.

12. Non-Liability of Officials and Employees of the District. No official or employee of DISTRICT shall be personally liable to CONTRACTOR in the event of any default or breach by DISTRICT, or for any amount which may become due to CONTRACTOR.

13. Conflict of Interest. No officer or employee of the DISTRICT shall have any financial interest, direct or indirect, in this Agreement nor shall any such officer or employee participate in any decision relating to the Agreement which effects his or her financial interest or the financial interest of any corporation, partnership, or association in which they are, directly or indirectly, interested in violation of any state statute or regulation. CONTRACTOR represents and warrants that it has not paid or given and will not pay or give any third party any money or other consideration in exchange for obtaining this Agreement.

14. Covenant Against Discrimination. In connection with its performance under this Agreement, CONTRACTOR shall not discriminate against any employee or applicant for employment because of race, disability, medical condition, religion, color, sex, sexual orientation, age, marital status, ancestry, or national origin. CONTRACTOR shall ensure that applicants are employed, and that employees are treated during their employment, without regard to their race, disability, medical condition, religion, color, sex, sexual orientation, age, marital status, ancestry, or national origin. Such actions shall include, but not be limited to, the following: employment, upgrading, demotion or transfer; recruitment or recruitment advertising; layoff or termination; rates of pay or other forms of compensation; and selection for training, including apprenticeship.

15. Independent Contractor. The legal relationship between the Parties is that of an independent contractor, and nothing herein shall be deemed to make CONTRACTOR a DISTRICT employee.

16. Notices. All notices shall be personally delivered or mailed to the below listed address, or to such other addresses as may be designated by written notice, and shall be deemed received upon the earlier of (i) the date of delivery to the address of the person to receive such notice if delivered

personally or by messenger or overnight courier; or (ii) five (5) business days after the date of posting by the United States Post Office if by mail. These addresses shall be used for delivery of service of process.

(CONTRACTOR) Paulus Engineering, Inc.
Attention: Rory Campbell, Vice President
2871 E. Coronado Street
Anaheim, CA 92806

(DISTRICT) Midway City Sanitary District
Attention: District Engineer
14451 Cedarwood Street
Westminster, CA 92863

(WITH COPY TO) Midway City Sanitary District
Attention: General Counsel
14451 Cedarwood Street
Westminster, CA 92863

17. Reports.

(a) Each and every report, draft, work product, map, video, record and other document, hereinafter collectively referred to as "Report", reproduced, prepared or caused to be prepared by CONTRACTOR pursuant to or in connection with this Agreement, shall be the exclusive property of DISTRICT. CONTRACTOR shall not copyright any Report required by this Agreement and shall execute appropriate documents to assign to District the copyright to Reports created pursuant to this Agreement. Any Report, information and data acquired or required by this Agreement shall become the property of DISTRICT, and all publication rights are reserved to DISTRICT.

(b) All Reports prepared by CONTRACTOR may be used by DISTRICT in execution or implementation of:

- (1) The original Project for which CONTRACTOR was hired;
- (2) Completion of the original Project by others;
- (3) Subsequent additions to the original Project; and/or
- (4) Other DISTRICT projects as appropriate.

(c) No Report, information or other data given to or prepared or assembled by CONTRACTOR pursuant to this Agreement shall be made available to any individual or firm by CONTRACTOR without prior approval by District.

18. Waiver. No waiver of any provision of this Agreement shall be effective unless in writing and signed by a duly authorized representative of the Party against whom enforcement of a waiver

is sought. Any waiver by the Parties of any default or breach of any covenant, condition, or term contained in this Agreement, shall not be construed to be a waiver of any subsequent or other default or breach, nor shall failure by the Parties to require exact, full, and complete compliance with any of the covenants, conditions, or terms contained in this Agreement be construed as changing the terms of this Agreement in any manner or preventing the Parties from enforcing the full provisions hereof.

19. Rights and Remedies Cumulative. Except with respect to rights and remedies expressly declared to be exclusive in this Agreement, the rights and remedies of the Parties are cumulative and the exercise by either Party of one or more of such rights or remedies shall not preclude the exercise by it, at the same or different times, of any other rights or remedies for the same default or any other default by the other Party.

20. Legal Action. In addition to any other rights or remedies, either Party may take legal action, in law or in equity, to cure, correct or remedy any default, to recover damages for any default, to compel specific performance of this Agreement, to obtain declaratory or injunctive relief, or to obtain any other remedy consistent with the purposes of this Agreement.

21. California Law; Venue. This Agreement shall be construed in accordance with the laws of the State of California. Any action commenced about this Agreement shall be filed in the central branch of the Orange County Superior Court.

22. Interpretation. This Agreement shall be construed as a whole according to its fair language and common meaning to achieve the objectives and purposes of the Parties. The terms of this Agreement are contractual and the result of negotiation between the Parties. Accordingly, any rule of construction of contracts (including, without limitation, California Civil Code Section 1654) that ambiguities are to be construed against the drafting party, shall not be employed in the interpretation of this Agreement. The caption headings of the various sections and paragraphs of this Agreement are for convenience and identification purposes only and shall not be deemed to limit, expand, or define the contents of the respective sections or paragraphs.

23. Entire Agreement; Modification. The Contract Documents constitute the entire agreement between the parties and supersedes any previous agreements, oral or written. This Agreement may be modified only by subsequent mutual written agreement executed by DISTRICT and CONTRACTOR.

24. No Third-Party Beneficiaries. Except as may be specifically provided for herein, nothing contained in this Agreement is intended to confer, nor shall this Agreement be construed as conferring, any rights, including, without limitation, any rights as third-party beneficiary or otherwise, upon any entity or person not a party hereto.

25. Severability. Whenever possible, each provision of this Agreement shall be interpreted in such a manner as to be effective and valid under applicable law, but if any provision of this Agreement shall be determined to be invalid by a final judgment or decree of a court of competent jurisdiction, such provision shall be ineffective only to the extent of such prohibition or invalidity, without invalidating the remainder of that provision, or the remaining provisions of this Agreement

unless the invalid provision is so material that its invalidity deprives either Party of the basic benefit of their bargain or renders this Agreement meaningless.

26. Corporate Authority. Each of the undersigned represents and warrants that (i) the Party for which he/she is executing this Agreement is duly authorized and existing, (ii) he/she is duly authorized to execute and deliver this Agreement on behalf of the Party for which he/she is signing, (iii) by so executing this Agreement, the Party for which he/she is signing is formally bound to the provisions of this Agreement, and (iv) the entering into this Agreement does not violate any provision of any other Agreement to which the Party for which he/she is signing is bound.

27. Counterparts; Facsimile Signatures. This Agreement may be executed in counterparts, all of which shall constitute the same Agreement, notwithstanding that all parties to this Agreement are not signatory to the same counterpart. Signature and acknowledgement pages may be detached from the counterparts and attached to a single copy of this Agreement to physically form one (1) original document. These counterparts may be transmitted by facsimile or Portable Document Format (PDF), with the originals to be thereafter provided by the Parties. Such facsimiles or electronic copies shall be deemed original signatures.

[SIGNATURES ON FOLLOWING PAGE]

IN WITNESS THEREOF, these parties have executed this Agreement as of the date first written above.

“DISTRICT”

MIDWAY CITY SANITARY DISTRICT,
a public entity

By:  _____
Robert Housley
General Manager

APPROVED AS TO FORM:

 _____
General Counsel
Midway City Sanitary District

“CONTRACTOR”

PAULUS ENGINEERING, INC., a
California corporation

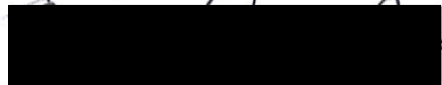
By:  _____
Name: PAULUS ENGINEERING
Title: VICE PRESIDENT

By: _____
Name: _____
Title: _____

Tax ID No. 33-6717252

If CONTRACTOR is a corporation, a Corporate Resolution and/or Corporate Seal is required. If a partnership, Statement of Partnership must be submitted to District.

EXHIBIT A
CONTRACTOR'S PROPOSAL

Paulus Engineering, Inc.

2-May-24



Midway City Pembroke Options

BID ITEM	DESCRIPTION	QUANTITY	UNIT	TOTAL BID	TOTAL
	Pothole Repair				
1	The following quote is to repair sinkhole, recompact 2-10' sections of pipe and make repairs, remove and replace existing manhole that has settled. We will repave this area with up to 6" hot asphalt.				
	<u>Inclusions</u>				
1	2-10' long spot repairs on existing sewer with recompacting underneath with slurry backfill per City Standards				
2	Remove and replace manhole non-lined with 1' of rock beneath and internal bypass as needed				
3	Remove 320 SD of asphalt and native material to bottom elevation of pipe. We will install imported jetted sand to 1' above existing pipe elevation and then put base to 6" asphalt subgrade compacted to 95% per City Standards. We will pave repair with 6" hot conventional asphalt.				
		1 LS		\$95,731.00	\$95,731.00
Subtotal Repair				\$95,731.00	

Optional Items and clarifications

If additional removal and replacement of sinkhole is needed will be \$93.00 a square foot
Excludes dewatering of groundwater if encountered
Excludes permits, fees, and bonds
Work based on prevailing wages
This is a lump sum quote
If we provide soils test add \$7,500.00

EXHIBIT B
PLANS AND SPECIFICATIONS

PLANS & SPECIFICATIONS

I. Scope of Work

The following is the scope of the Work. See the attached plans for more information.

1. (2) 10 LF of 8" VCP sewer pipe replacement repair based on MCSD Standards (Standard Detail S-010) with recompacting underneath with slurry backfill per City of Westminster Standards.
 - a. The first segment is on Webber Pl, Westminster, 10 linear feet from MH2006 toward MH2005.
 - b. The second segment is on Pembroke Ln, Westminster, 10 linear feet from MH2006 toward MH2019.
2. (1) Remove and replace un-lined manhole based on MCSD Standards (Standard Detail S-045A) with 12 inches of aggregated base underneath as needed.
3. Remove 320 SF of asphalt and native material to the bottom elevation of pipe. Install imported jetted sand to 12 inches above existing pipe elevation. The repair of the street shall be done based on City of Westminster Standards.
4. Compaction Testing is required based on City of Westminster Standards - Standard Drawing #609. Therefore, 95% compaction is required for all levels (i.e., base, sub-grade, asphalt, etc.) based on Caltrans Standards.
5. Replacement of additional VCP sewer pipe and additional removal and replacement of native materials, installation of sand, and street repair at the Work location as directed by the District Engineer if necessary to adequately remedy the Emergency.
6. Dewatering of groundwater if encountered.

All Work shall be done based on the following standards:

1. Cal/OSHA standards.
2. Midway City Sanitary District Design and Construction Requirements for Sanitary Sewers (See attached).
3. City of Westminster Standards – Standard Drawing #609: Utility Excavation in the Public Right of Way (see attached).
4. Vitrified Clay Pipe Installation & Inspection Handbook (2020 edition).

Contractor is responsible for coordinating all Work with the City of Westminster.

II. Schedule of Performance

The Work is required to remedy an Emergency and must be commenced and completed as soon as possible. In addition, the City of Westminster is planning a street repair project at the location of the Work. Contractor is responsible for coordinating all Work with the City of Westminster in order to complete the Work prior to commencement of the City's street repair project at the Work location. Contractor shall commence the Work as soon as possible following full execution of the Agreement. All Work must be completed on or before May 24, 2024, unless otherwise agreed by the District and the City of Westminster.

III. General Provisions

The following General Provisions apply to the Work.

A. Liability for Costs and Responsibility.

The Contractor will be required to assume responsibility for all services offered in the proposal whether or not they possess them within their firm. The Contractor will be the sole point of contact with regard to contractual matters, including payment of any and all charges resulting from the Contract.

B. Permits.

The Contractor and all of its subcontractors shall obtain and maintain during the term of the Agreement all appropriate permits required in connection with the performance of the Project.

The required permits include:

- Traffic control plans and encroachment permits are required from the City of Westminster.
- Confined Space Permit is required from the District for entering into any District's manholes. Confined space procedures will be provided with the permit.
- Any other permit which is required by the local agency and the local jurisdiction.

C. Licenses and Certificates.

The Contractor and all of its subcontractors, at its and/or their sole expense, shall obtain and maintain during the term of the Contract, all appropriate licenses and certificates required in connection with the performance of the Project.

The required Licenses and Certificates include:

- General contractor license A, C36, or C42.
- Business Licenses are required from the City of Westminster.
- Any other Licenses and Certificates which is required by the local agency and the local jurisdiction.

D. Spill Prevention and Clean Up.

Spill prevention and clean up shall be performed based on instructions and guidelines by Orange County Public Works Standards that can be found at:

<https://ocerws.ocpublicworks.com/sites/ocpwocerws/files/import/data/files/10193.pdf>

In case of observation of Sewer System Overflow (SSO), please call District's emergency numbers: 714-310-9004 or 714-310-8654.

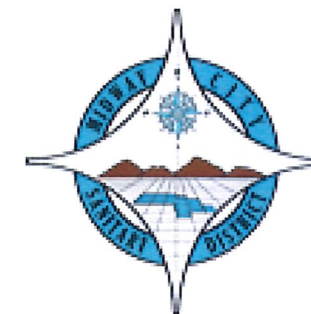

Midway City Sanitary District Emergency Repair Project

DATE: 05/02/2024
SCALE: 1" = 80'



Construction Notes:

- (2) 10 LF of 8" VCP sewer pipe replacement repair based on MCSD Standards (Standard Detail S-010) with recompacting underneath with slurry backfill per City of Westminster Standards.
- (1) Remove and replace manhole based on MCSD standards (Standard Detail S-045A) with 12 inches of aggregated base underneath as needed.
- Remove 320 SF of asphalt and native material to the bottom elevation of pipe. Install imported jetted sand to 12 inches above existing pipe elevation. The repair of the street shall be done based on City of Westminster Standards.
- All work shall be done based on Cal/OSHA standards.

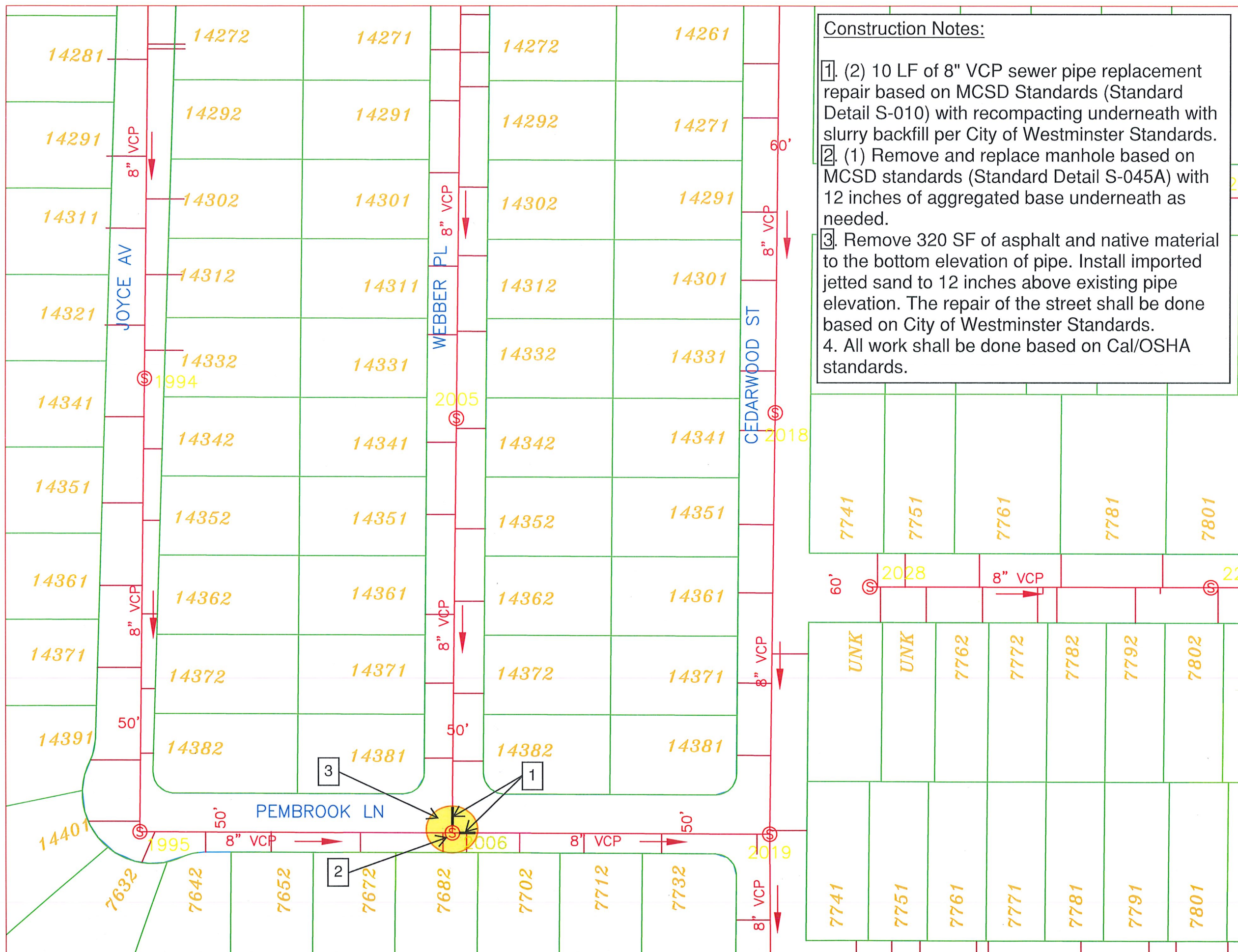

Legend

- Limits of Work
- 13933 Property Number
- Property Line
- MCSD Sewer Line
- OCSD Trunk
- WESTMINSTER BLVD Street Name
- ⊕ Sewer Manhole
- Flow Direction
- 8" VCP Pipe Size & Type

**DESIGN AND CONSTRUCTION
REQUIREMENTS
FOR SANITARY SEWERS**

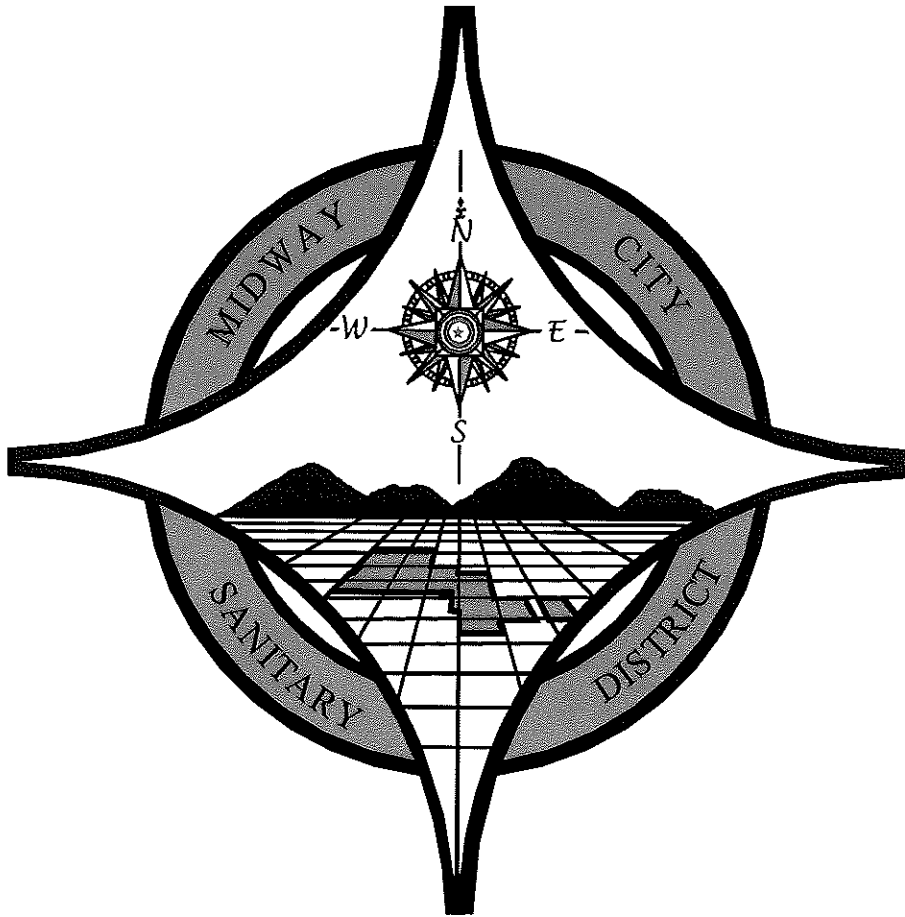

**MIDWAY CITY SANITARY DISTRICT
WESTMINSTER, CALIFORNIA
BOARD APPROVED 11/2/2010**

TABLE OF CONTENTS

	<u>PAGE</u>
<u>SECTION 1 – GENERAL</u>	1
1-1 – Definitions	1
1-2 – Plan Check and Approval of Plans	1
1-3 – Payment of Fees	1
1-4 – “As-Built” Drawings	1
<u>SECTION 2 – DESIGN REQUIREMENTS</u>	2
2-1 – Design Criteria	2
2-2 – Preparation of Drawings	3
2-3 – Sewer Construction on Private Property	3
<u>SECTION 3 – INSPECTION OF WORK</u>	4
<u>SECTION 4 – SEWER CONSTRUCTION</u>	6
4-1 – General	6
4-2 – Connection to Existing Facilities	6
4-3 – Sewer and Water Separation	6
4-4 – Special Provisions	6
<u>SECTION 6 – STANDARD DRAWINGS</u>	8
S-010 Pipe Installation and Pavement Replacement	8
S-011 Sewer – Storm Drain Crossing	9
S-012 2 Way Clean Out on Private Property	10
S-013 Raised Sewer Manhole in Alley Gutter	11
S-015 Sewer Clean Out Cover and Frame Installation	12
S-018 Concrete Encasement Type A, B, & C	13
S-019 Pipeline Separation Requirements	14
S-020 Pipe Support Beam Across Trenches	16
S-021 Pipe Support Wall Across Trenches	17
S-022 Sewer House Lateral at Utility Intersection	18
S-023 Anchor Block Detail	19
S-030A Steel Pipe Casing	20
S-040 Field Closure for V.C.P.	21
S-044 Bell Ring Insert with PVC Plate Liner	22
S-045A Un-Lined Manhole for Sewers	23
S-050A PVC-Lined Manhole for Sewers	24
S-051 Drop Manhole Connection to Standard Manhole	27
S-053A Standard Manhole Frame and Cover	28
S-054A Bolted Manhole Frame and Cover	29
S-055A Manhole Adjustment to Grade	30
S-056 PVC Liner and Gas Flap Installation at Laterals	31
S-057 Gas Flap Installation for NON-PVC Lined or Unlined Manholes	32
S-065 Liner-PVC	33
S-070 Saddle Connection	34
S-071 Cut in WYE Connection	35
S-072 House Lateral, Typical	36
S-073 Clean Out Detail in Roadway	37
Grease Interceptor Tank with Sample Box	38

SECTION 1 – GENERAL

1-1 DEFINITIONS

DISTRICT - Midway City Sanitary District

DISTRICT ENGINEER – Engineer or Authorized Representative for the District

STANDARD SPECIFICATIONS FOR PUBLIC WORKS CONSTRUCTION

All references to the standard Specifications refer to the latest edition as revised or amended at the date of construction.

ASTM – The American Society for Testing and Materials, latest revision.

APPROVED EQUAL – A material or product that is equivalent to or exceeds, in the opinion of the District Engineer, in all respects, that which is specified.

1-2 PLAN CHECK AND APPROVAL OF PLANS

Construction drawings of the proposed sewer construction within the District boundary shall be submitted and approved by the District Engineer, attested to by the Engineer's signature on the drawings. This approval shall apply only to general design concepts and does not guarantee the absence of errors or omissions.

1-3 PAYMENT OF FEES

Prior to approval of plans and connections to District sewers, the developer shall pay all fees as required under current District policy. Fees will be determined by the District Engineer at time of plan check.

1-4 "AS-BUILT" DRAWINGS

In the case dedicated sewer main is constructed, the Design Engineer shall "As-Built" the original drawings to the satisfaction of the District Engineer and provide the District with a set of duplicate mylars.

SECTION 2 – DESIGN REQUIREMENTS

2-1 Design Criteria

(a) Minimum size – The minimum size for sewer mains shall be 8-inches and for laterals 4-inches.

(b) Sewer Slop – Minimum pipeline slopes shall be:

<u>Pipe Size (Mains)</u>	<u>Grade</u>
8 inch	0.40%
10 inch	0.28%
12 inch	0.22%
15 inch	0.16%
18 inch	0.12%
4 inch (laterals)	2.0%

(c) Pipe Capacity – Pipelines shall be designed to carry estimated peak flow as follows:

18-inch or smaller – flowing $\frac{1}{2}$ full

21-inch or larger – flowing $\frac{3}{4}$ full

(d) Manholes – Manhole construction is required at the following locations:

- (1) At changes of slop
- (2) At changes of direction
- (3) At changes of pipe size
- (4) At junction of laterals larger than 6-inches
- (5) At intervals not exceeding 350 feet
- (6) At termination of sewer mains
- (7) At special locations as designated by the District Engineer

Elevation drop through manholes shall be 0.10 foot minimum.

SECTION 2 – DESIGN REQUIREMENTS (Continued)

(e) Pipe Material – Polyvinyl Chloride (PVC) pipe is approved for all sewer line construction. Vitrified Clay Pipe (VCP) pipe may be specified only with prior approval from the District Engineer. Ductile Iron Pipe (DIP), or Class 200 Polyvinyl Chloride (PVC) – C900, shall be used for sewer construction within the vicinity of water mains as in Standard Drawing S-019.

(f) Curved Sewer – Curved sewer may be specified only with prior approval from the District Engineer.

2-2 Preparation of Drawings

All sewer plans shall be prepared as follows:

Sheet Size: 24 by 36 inches

Scales: Horizontal – one inch equals 40 feet. Vertical – one inch equals 4 feet for sewer slopes less than 10 percent. One inch equals 8 feet for slopes greater than 10 percent.

Sewer Plans: Sewer plan shall show both existing and proposed construction and shall include standard notes and a signature block for the District Engineer. (Sewer profile will be required when public sewer main is proposed.)

Sewer Mains and Lateral Location: Sewer Mains and Lateral location shall be shown on the plans and located by stationing. Stationing shall conform to the existing stationing.

2-3 Sewer Construction on Private Property

Sewer mains constructed on private property that are to be maintained by the Midway Way City Sanitary District shall be shown within a 20 foot easement to be dedicated to the District. Only under instances approved by the Board of Directors and the District Engineer will sewer within easements be accepted by the District.

SECTION 3 – INSPECTION OF WORK

The Midway City Sanitary District (MCSD) shall provide an inspector for the Inspection of all sewer improvements constructed within the public right-of-way or MCSD easements. All work shall be left open and uncovered until the installation is observed by the District Inspector. The contractor shall not proceed with any subsequent phase of work until the previous phase has been inspected by the District.

The term inspection referred to herein shall mean observation by the District Inspector or other District representative and does not constitute or imply any guarantees.

Inspection shall be made at the following intervals of work:

- (a) Trench excavation and bedding
- (b) Placing of pipe, fittings and structures
- (c) Placing and compacting of the pipe bedding
- (d) Backfill of balance of trench to grade; in public right-of-way, Performed by local governing agency; within easements, entire backfill to be under inspection by the District Inspector
- (e) Balling and cleaning, air testing and mirroring, after receipt of Compaction certification, but prior to paving
- (f) Repairs made after initial inspection
- (g) After manholes are raised to grade
- (h) Saddle or manhole connections to existing sewers

The District shall at all times have access to work during construction and shall be furnished with every reasonable facility for ascertaining full knowledge of the progress, workmanship and character of materials used and employed in the work.

No pipe, fitting or other materials shall be installed until inspected by the District or its representative. All installations which are to be backfilled shall be inspected prior to backfilling and the contractor shall give due notice to the District Engineer in advance of backfilling so that proper inspection may be provided.

SECTION 3 – INSPECTION OF WORK (Continued)

The inspection of the work shall not relieve the contractor of any of his obligations to complete the work as prescribed by these specifications. defective work shall be made good, and unsuitable materials may be rejected notwithstanding the fact that such defective work and unsuitable materials have been previously overlooked by the District and accepted.

The District shall have the authority to suspend the inspection of the work wholly or in part for such time as it may deem necessary due to the failure on the part of the contractor to comply with these specifications as determined by the District Engineer. Any work performed without inspection of the District shall be considered unacceptable.

SECTION 4 – SEWER CONSTRUCTION

4-1 General

All work shall conform to the standard Specifications for Public Works Construction except as modified herein, the work Area Traffic Control Watch Manuel Handbook, and the standard Plans and Specifications of the Midway City Sanitary District.

The contractor shall be responsible for obtaining all necessary permits and shall Comply with all safety ordinances, regulations, orders, and shall be solely Responsible for the safety conditions of the work.

4-2 Connection to Existing Facilities

Modification to existing manhole shall be done by core drilling unless otherwise approved by the District Engineer. New channels in existing manholes shall be finished smooth and shaped in the direction of flow. Any annular space around the pipe at the manhole base shall be filled with plastic cement (1:3 field mix).

4-3 Sewer and Water Separation

All new sewer construction shall maintain a minimum distance of 10 feet horizontally and 1 foot vertically below water mains. Any construction above the water main or in violation of the basic separation requirements shall be done per Standard Drawing S-019.

4-4 Special Provisions

The following additions are made to the Standard Specifications for Public Works Construction:

Adjustment of Manholes Frame and Cover Sets to Grade

Prior to asphalt concrete paving, manhole frame and covers shall be left 6 inches below finish grade. After street surfacing is completed, frames and covers shall be raised to grade per Standard Drawing S-055A. Whenever manholes are constructed in unpaved areas, the manhole covers shall be set 18 inches above finished grade.

SECTION 4 – SEWER CONSTRUCTION (continued)

Bedding

Pipe bedding shall meet the approval of the District Engineer and local governing agencies.

Field Jointing of Clay Pipe

Only Type "G" joints are approved for vitrified clay pipe (VCP) with the exception That Type "D" joints may be used for laterals and sewer repair work.

Backfill and Densification

All trench backfill and bedding shall be compacted to 90 percent minimum Relative compaction unless otherwise required by the local governing agency.

Trench Resurfacing

Trench resurfacing shall meet the requirements of the local governing agency.

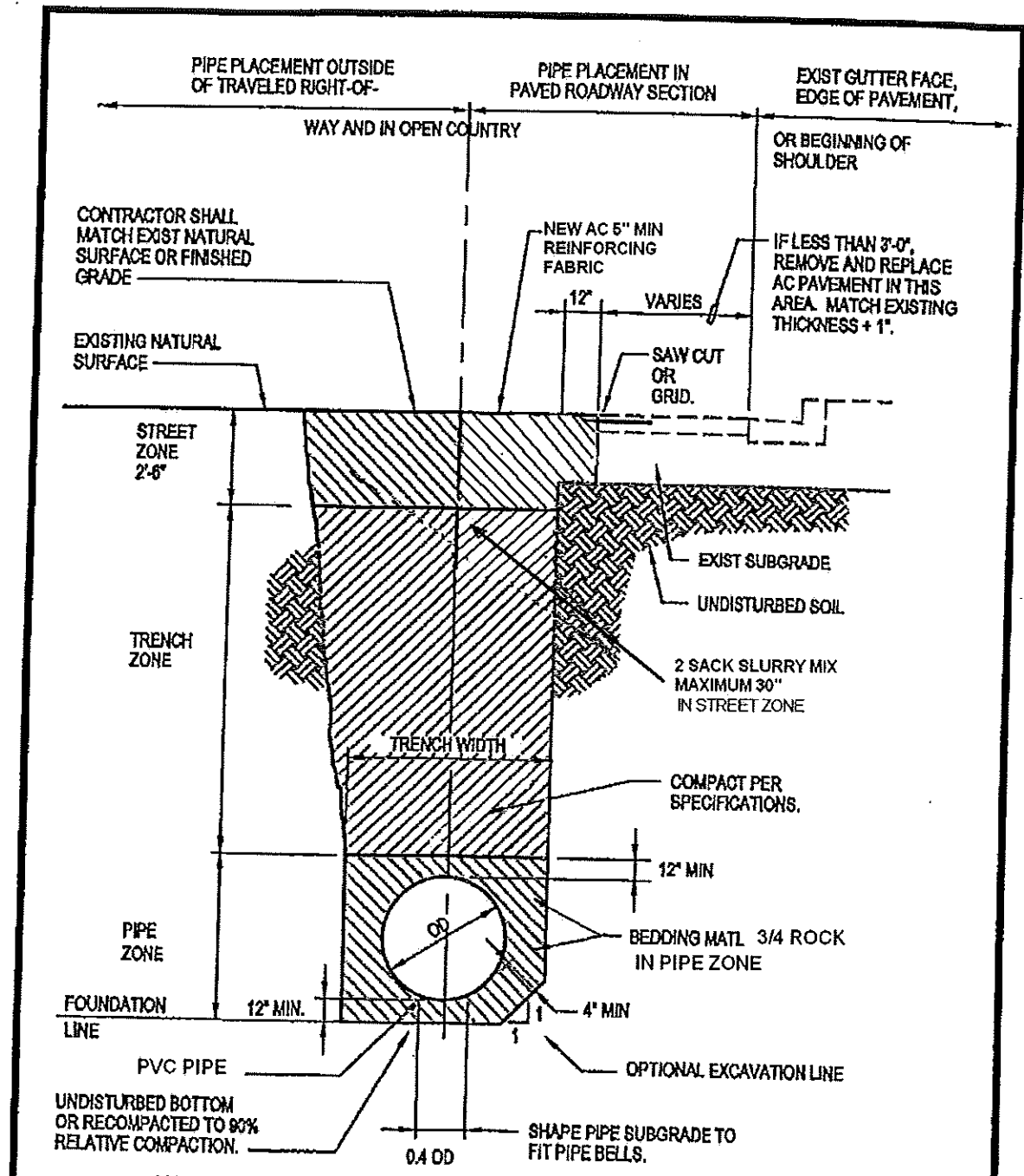

NOTE:
 TRENCH WIDTH, BEDDING AND BACKFILL MATERIALS, COMPACTION AND PAVING PER SPECIFICATIONS.

NO.	APPROVED	DATE

MIDWAY CITY SANITARY DISTRICT
 WESTMINSTER, CA
[Signature] 11/2/2009

PIPE INSTALLATION
 AND
 PAVEMENT REPLACEMENT

NO SCALE
 STANDARD DWG.
S-010

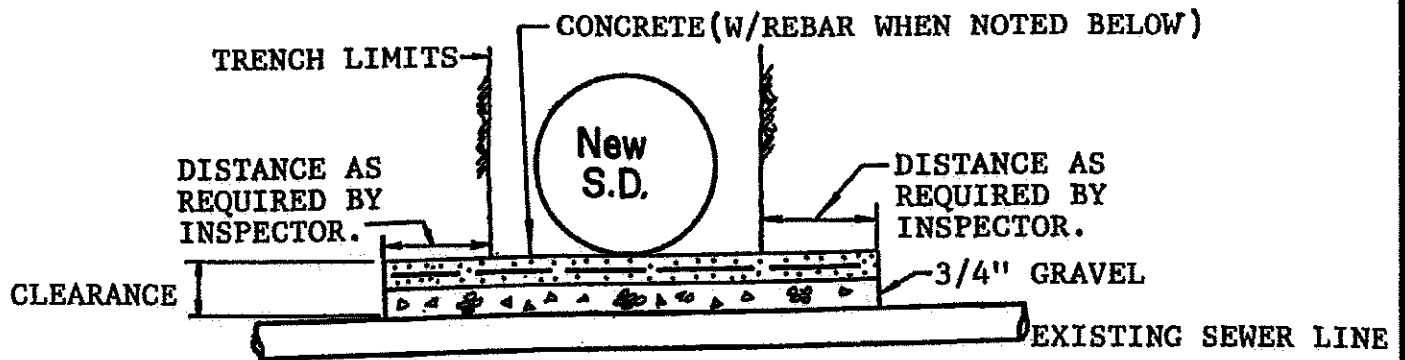

IF CLEARANCE IS 8" TO 18", USE 4" CONCRETE SLAB OVER 4" OF 3/4" GRAVEL.
 IF CLEARANCE IS LESS THAN 8", USE CONCRETE SLAB W/ REBAR OVER 3/4" GRAVEL
 AS REQUIRED BY INSPECTOR.

CASE I

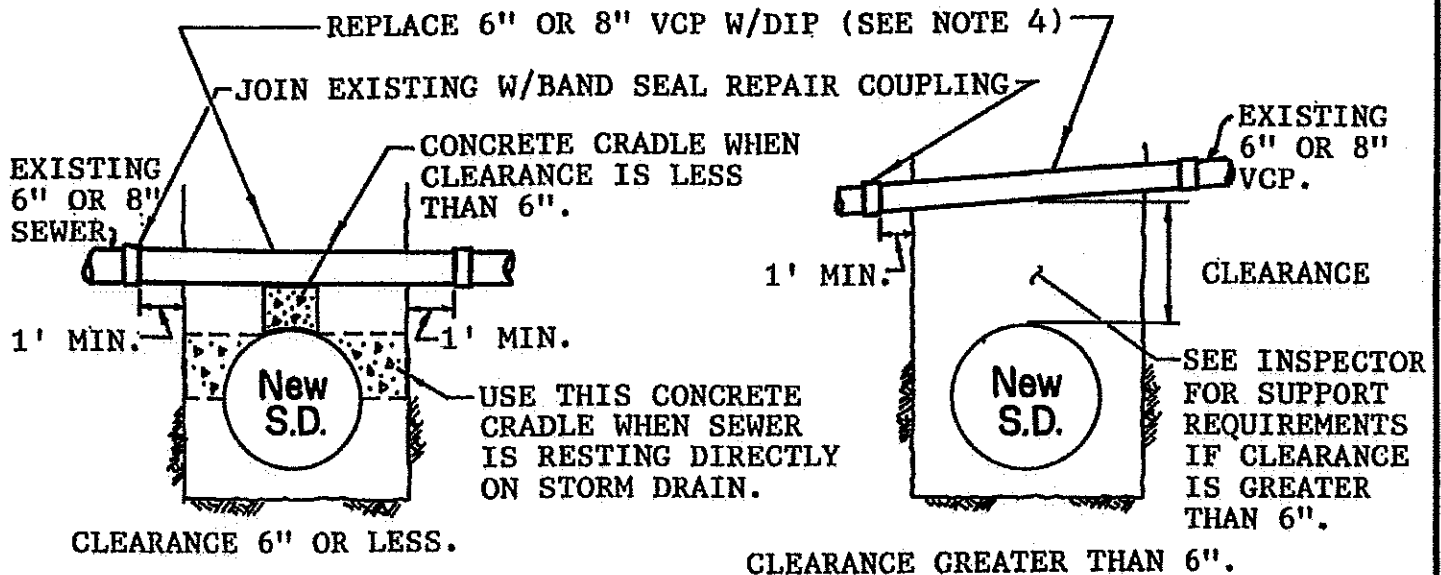

CLEARANCE 6" OR LESS.

CASE II

CLEARANCE GREATER THAN 6".

CASE III

Notes:

1. For use in conjunction with storm drain construction in the vicinity of sewer lines to prevent damage to sewer during backfill operation.
2. This standard does not meet the State Department of Health requirements for sewer and water crossing.
3. Case III may be used with the construction of new water main with prior approval of District Engineer.
4. 10" VCP or larger to be protected in place per inspector requirements.
5. Concrete shall be Class 420-C-2000.

		MIDWAY CITY SANITARY DISTRICT WESTMINSTER, CA.		SEWER - STORM DRAIN CROSSING		NO SCALE	
		<i>King [Signature]</i> 11/2/2010				STANDARD DWG.	
NO.	APPROVED			DATE			S-011

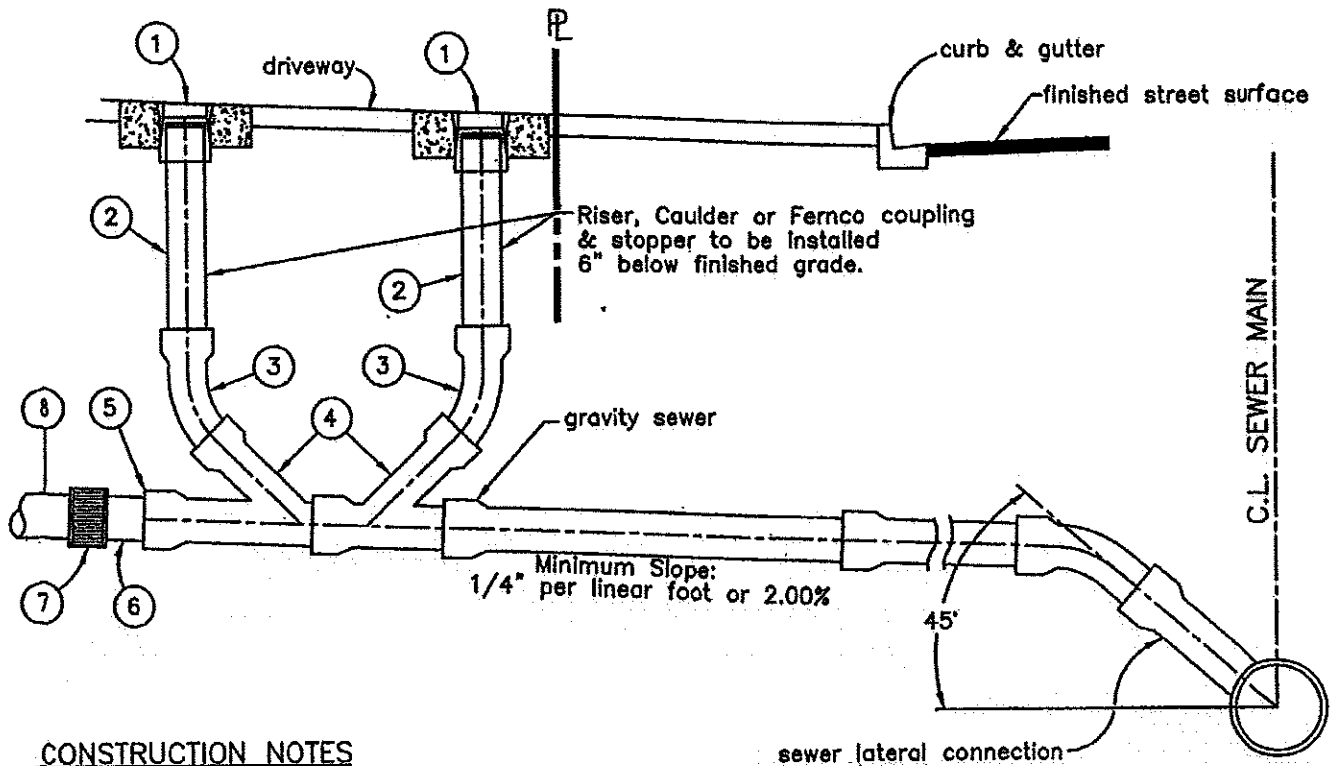

CONSTRUCTION NOTES

- ① Install sewer cleanout cover traffic rated.
- ② 4" (or 6") SDR-35 PVC sewer pipe with gasketed, integral bell and spigot joints.
- ③ 4" (or 6") SDR-35 PVC 45° bend.
- ④ 4" x 4" (or 6"x 6") SDR-35 PVC wye branch fitting.
- ⑤ 4" (or 6") ABS stopper (where laterals are stubbed)
- ⑥ 4" (or 6") short piece, SDR-35 PVC, 6-inches long.
- ⑦ 4" (or 6") rubber mechanical banded seal clamp. Fernco or approved equal.
- ⑧ 4" (or 6") private sewer lateral.

GENERAL NOTES

- 1 Minimum slope for 4" or 6" sewer lateral shall be 1/4" per foot unless authorized.
- 2. Sewer cleanout shall include a stopper over risers. Use Mission Clay products stopper or equal.
- 3. Sewer cleanout riser pipe material shall be 4" or 6" VCP, ABS, SDR-35.
- 4. A cleanout shall be installed on all sewer lateral connections.
- 5. PVC shall be SDR-35 per ASTM 3034.
- 6. PVC pipe and fittings shall be bedded with 3/4" aggregate base rock material.
- 7 Where VCP materials are used, bedding shall be 3/4" aggregate base rock material.

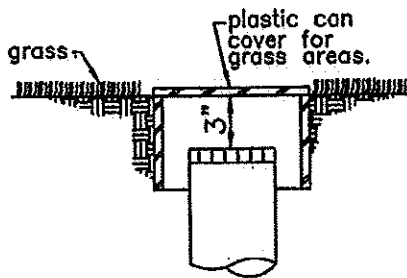

DETAIL-UNPAVED AREA

		MIDWAY CITY SANITARY DISTRICT WESTMINSTER, CA		2 WAY CLEAN OUT ON PRIVATE PROPERTY		NO SCALE	
		<i>[Signature]</i> 11/21/2010				STANDARD DWG.	
NO.	APPROVED	DATE					S-012

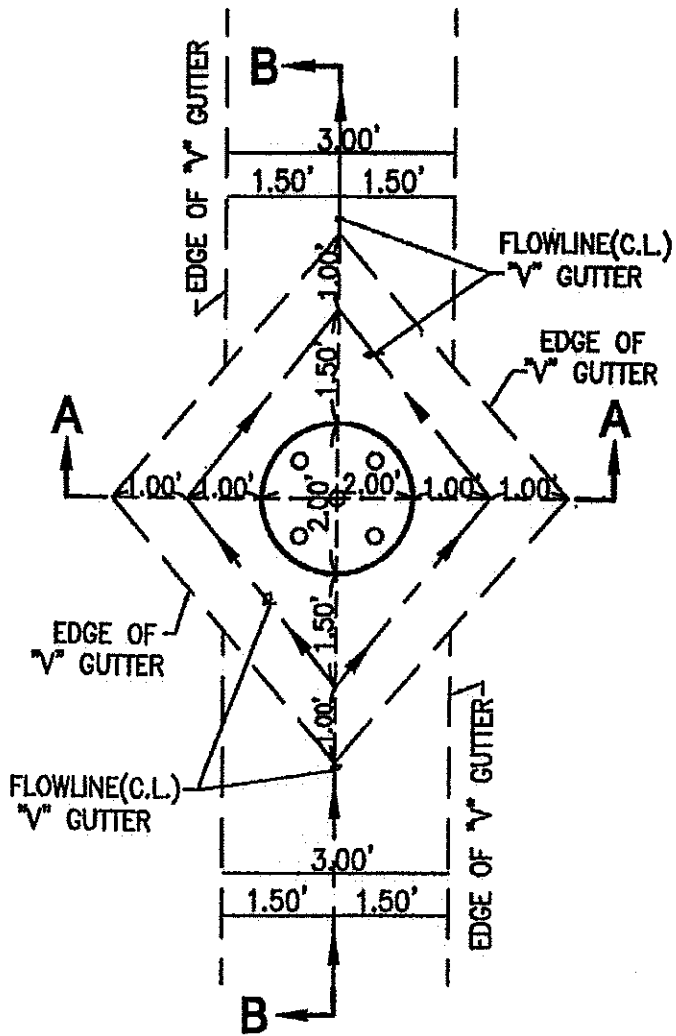

PLAN

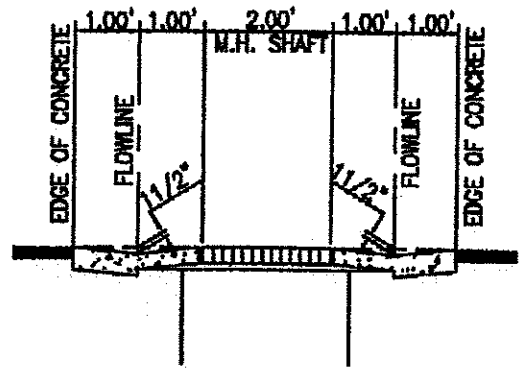

SECTION A-A

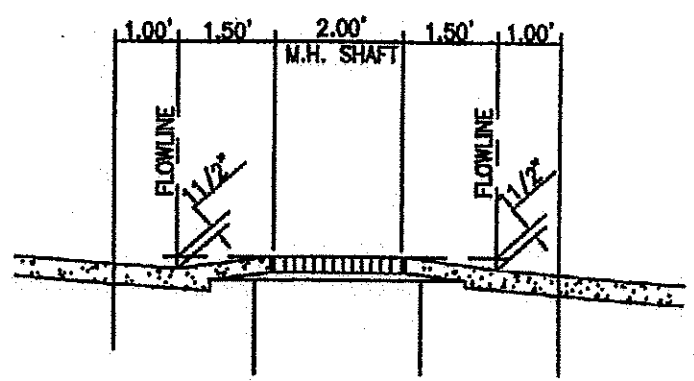

SECTION B-B

			MIDWAY CITY SANITARY DISTRICT WESTMINSTER, CA.		RAISED SEWER MANHOLE IN ALLY GUTTER		NO SCALE	
			<i>[Signature]</i> 11/2/2010				STANDARD DWG.	
NO.	APPROVED	DATE					S-013	

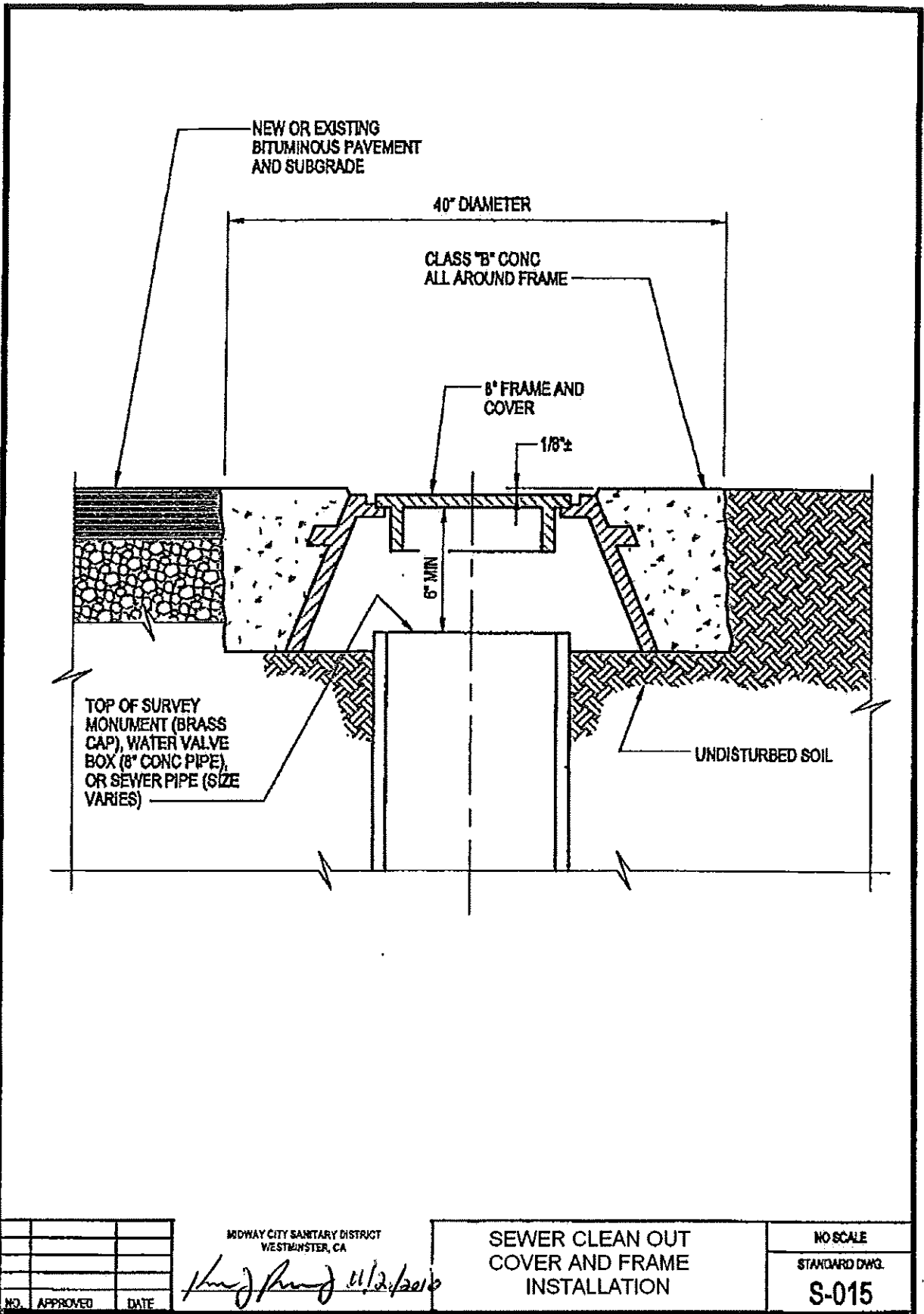

NO.	APPROVED	DATE

MIDWAY CITY SANITARY DISTRICT
WESTMINSTER, CA

[Signature] 11/2/2010

SEWER CLEAN OUT
COVER AND FRAME
INSTALLATION

NO SCALE
STANDARD DWG.
S-015

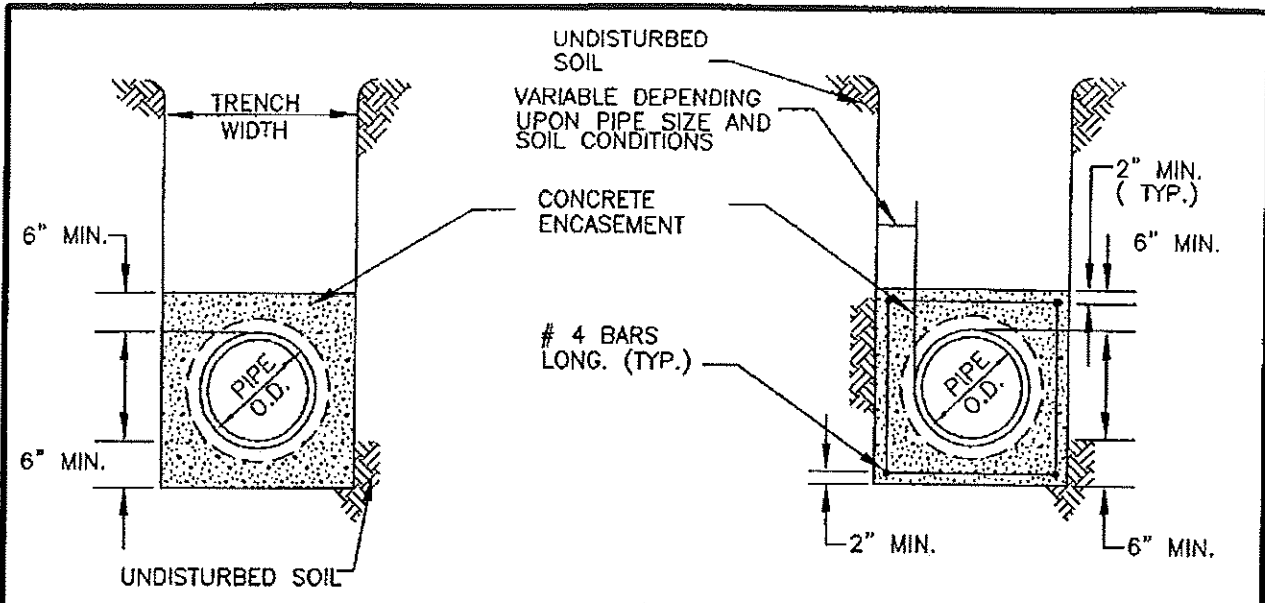

TYPE "A"

TYPE "B"

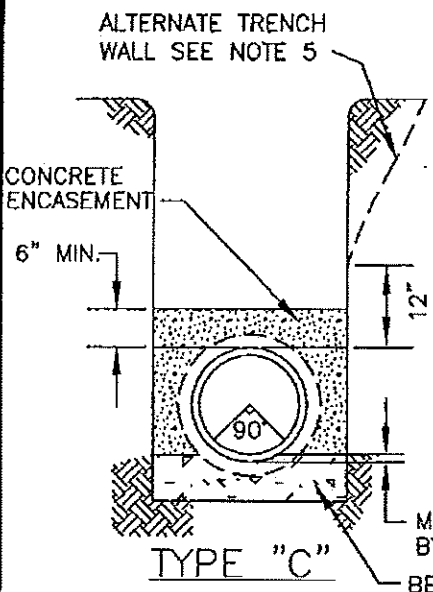

TYPE "C"

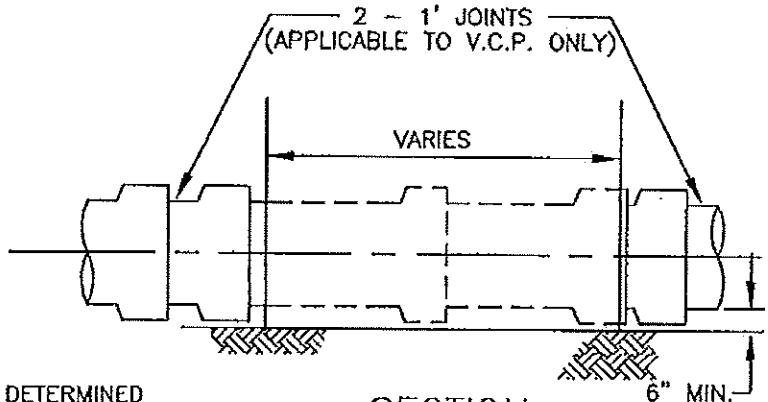

SECTION

NOTES:

1. CONCRETE ENCASEMENT SHALL BE USED WHEN COVER IS UNDER 4' OR OVER 20'.
2. ENCASEMENT TO BE PLACED AGAINST UNDISTURBED NATURAL GROUND OR FILL COMPACTED TO 90% RELATIVE DENSITY.
3. NO. 4 STEEL REINFORCING BARS SHALL BE USED AS SPECIFIED.
4. TYPE OF CONCRETE ENCASEMENT TO BE USED WILL BE SHOWN ON PLANS OR AS SPECIFIED BY DISTRICT REPRESENTATIVE TO MEET UNFORSEEN FIELD CONDITIONS. UNLESS NOTED OTHERWISE, ENCASEMENT SHALL BE CLASS "B" CONCRETE.
5. WHERE SLOPED TRENCHES ARE USED, WALLS WILL NOT BEGIN TO SLOPE CLOSER THAN 12" FROM THE TOP OF THE PIPE.

MIDWAY CITY SANITARY DISTRICT WESTMINSTER, CALIFORNIA	<h2>CONCRETE ENCASEMENT</h2> <h3>TYPE A, B, & C</h3>	NO SCALE
<i>[Signature]</i> 11/2/2010		STANDARD DWG. S-018

BASIC SEPARATION STANDARDS

1. PARALLEL CONSTRUCTION: THE HORIZONTAL DISTANCE BETWEEN PRESSURE DOMESTIC WATER AND RECLAIMED WATER MAINS AND SEWER LINES SHALL BE AT LEAST 10 FEET.
2. PERPENDICULAR CONSTRUCTION (CROSSING): PRESSURE WATER MAINS SHALL BE AT LEAST ONE FOOT ABOVE SANITARY SEWER AND RECLAIMED WATER LINES WHERE THESE LINES MUST CROSS.
3. SPECIAL PROVISIONS: ALTERNATIVE CONSTRUCTION CRITERIA WHERE THE BASIC SEPARATION STANDARDS CANNOT BE ATTAINED ARE SHOWN BELOW:

SITUATION:

LOCATION OF NEW SEWER & RECLAIMED WATER LINES TO EXISTING DOMESTIC & RECLAIMED WATER LINES.

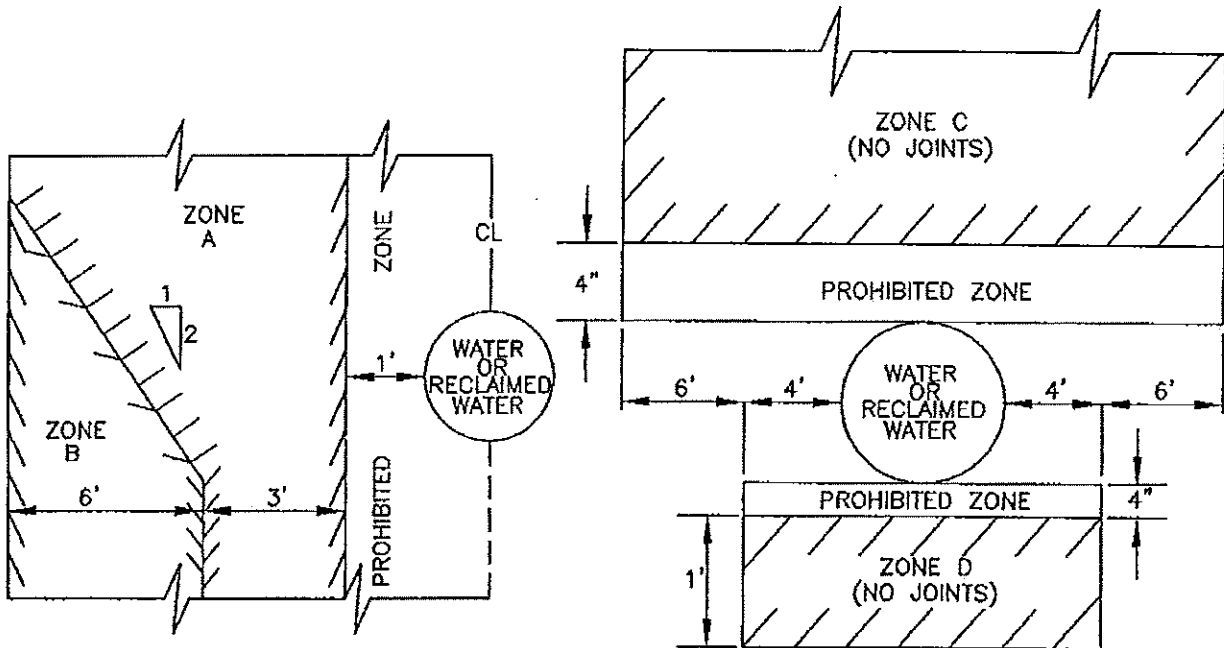

PARALLEL CONSTRUCTION

PERPENDICULAR CROSSING

IF ANY SEWER OR RECLAIMED WATER PIPELINES ARE TO BE CONSTRUCTED WITHIN ANY OF THE ABOVE INDICATED ZONES, SPECIAL CONSTRUCTION SHALL BE REQUIRED AS DESCRIBED BELOW.

ZONE SEWER

RECLAIMED WATER

- | | |
|---|---|
| <p>A DO NOT LOCATE ANY PARALLEL SEWER OR RECLAIMED WATER LINES IN THIS AREA WITHOUT STATE AND LOCAL HEALTH DEPARTMENT APPROVAL.</p> <p>B USE V.C.P. OR D.I.P. WITH COMPRESSION JOINTS.</p> <p>C USE D.I.P. WITH MECHANICAL JOINTS OR CLASS 200 P.V.C. - AWWA C900</p> <p>D USE D.I.P. OR CLASS 200 P.V.C. - AWWA C900</p> | <p>USE D.I.P. OR CLASS 200 P.V.C. - AWWA C900</p> <p>USE D.I.P. OR CLASS 200 P.V.C. - AWWA C900</p> <p>USE D.I.P. OR CLASS 200 P.V.C. - AWWA C900</p> |
|---|---|

MIDWAY CITY SANITARY DISTRICT
WESTMINSTER, CALIFORNIA

PIPELINE SEPARATION
REQUIREMENTS
SHEET 1 OF 2

NO SCALE

STANDARD DWG.

S-019

[Signature] 11/2/2010

GENERAL NOTES

1. NO PIPE JOINTS SHALL BE PERMITTED WITHIN ZONE D. IT IS THE INTENT OF THESE SPECIFICATIONS THAT NO JOINTS SHALL OCCUR WITHIN ZONE C. IF THAT CANNOT BE ACCOMPLISHED, THE NEW PIPELINE SHALL BE ENCASED IN CONCRETE FOR THE FULL LENGTH OF ZONE C. ENCASEMENT SHALL BE PER STD. DWG. S-018, TYPE "B"
2. ALL D.I.P. MUST HAVE HOT DIP BITUMINOUS COATING AND ALL CLASS 200 P.V.C. MUST MEET DR-14 PER AWWA C900 OR EQUIVALENT.
3. SEWER FORCE MAINS SHALL NOT BE PERMITTED IN ZONES A THROUGH D.
4. THIS CRITERIA DOES NOT APPLY FOR A RECLAIMED WATER LINE CROSSING ANOTHER RECLAIMED WATER LINE.
5. THE CONSTRUCTION CRITERIA APPLY TO HOUSE LATERALS THAT CROSS ABOVE A PRESSURE WATER MAIN BUT NOT TO THOSE HOUSE LATERALS THAT CROSS BELOW A PRESSURE WATER MAIN.

SITUATION:

LOCATION OF NEW & RECLAIMED WATER LINES TO EXISTING SEWER & RECLAIMED WATER LINES.

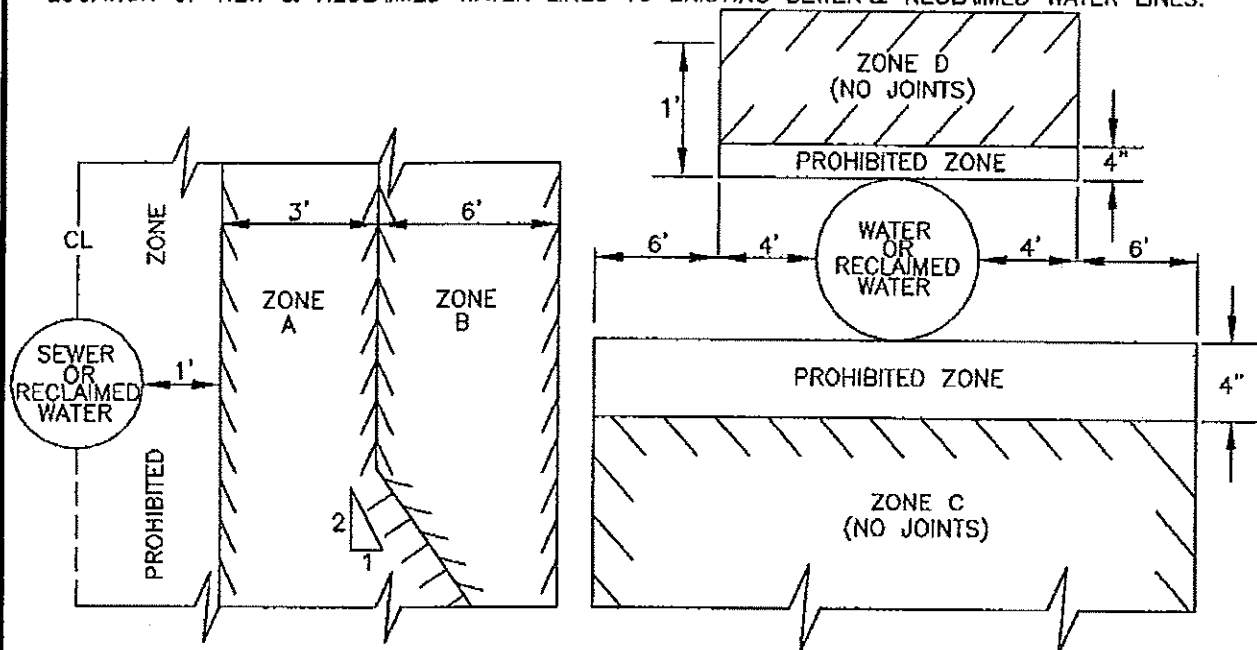

PARALLEL CONSTRUCTION

PERPENDICULAR CROSSING

IF ANY WATER OR RECLAIMED WATER PIPELINES ARE TO BE CONSTRUCTED WITHIN ANY OF THE ABOVE INDICATED ZONES, SPECIAL CONSTRUCTION SHALL BE REQUIRED AS DESCRIBED BELOW.

ZONE DOMESTIC WATER OR RECLAIMED WATER

- A DO NOT LOCATE ANY PARALLEL DOMESTIC WATER OR RECLAIMED WATER MAIN IN THIS AREA. WITHOUT STATE AND LOCAL HEALTH DEPARTMENT APPROVAL.
- B USE D.I.P. OR CLASS 200 P.V.C. - AWWA C900
- C USE D.I.P. OR CLASS 200 P.V.C. - AWWA C900
- D USE D.I.P. OR CLASS 200 P.V.C. - AWWA C900

MIDWAY CITY SANITARY DISTRICT
WESTMINSTER, CALIFORNIA

Handwritten signature and date: 11/2/2010

PIPELINE SEPARATION
REQUIREMENTS
SHEET 2 OF 2

NO SCALE

STANDARD DWG.

S-019

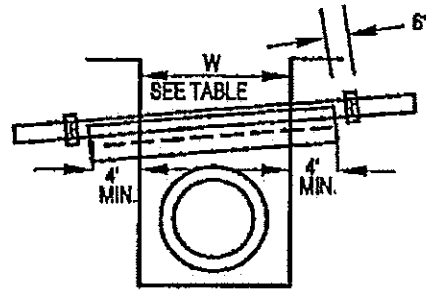
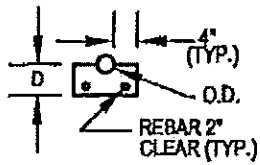
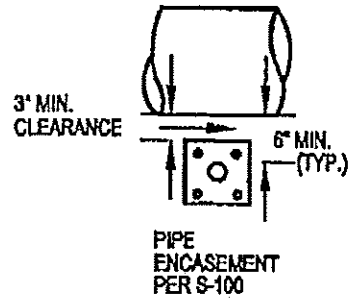
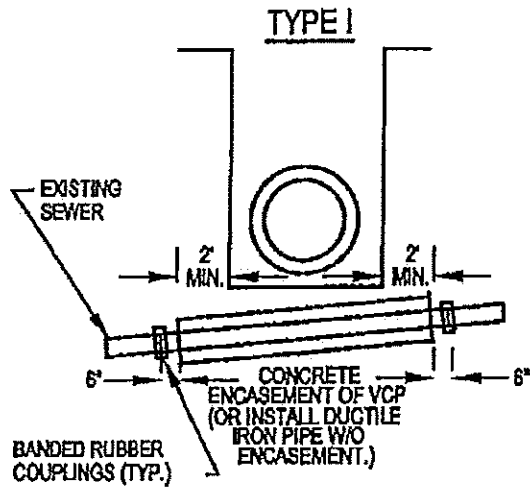

TYPE II

W	DEPTH OF COVER			
	0' TO 6'		8' TO 16'	
	D	BAR #	D	BAR #
3'	12"	4(13)	12"	4(13)
4'	12"	4(13)	12"	5(16)
5'	12"	4(13)	16"	5(16)
6'	12"	5(16)	16"	5(16)
7'	12"	5(16)	16"	6(19)
8'	12"	5(16)	16"	6(19)
9'	12"	6(19)	16"	8(25)
10'	12"	6(19)	16"	8(25)

NOTE:

() DENOTES METRIC SYSTEM.

NO.	APPROVED	DATE

MIDWAY CITY SANITARY DISTRICT
WESTMINSTER, CA

[Signature] 11/2/2016

PIPE SUPPORT
BEAM
ACROSS TRENCHES

NO SCALE
STANDARD DWG.
S-020

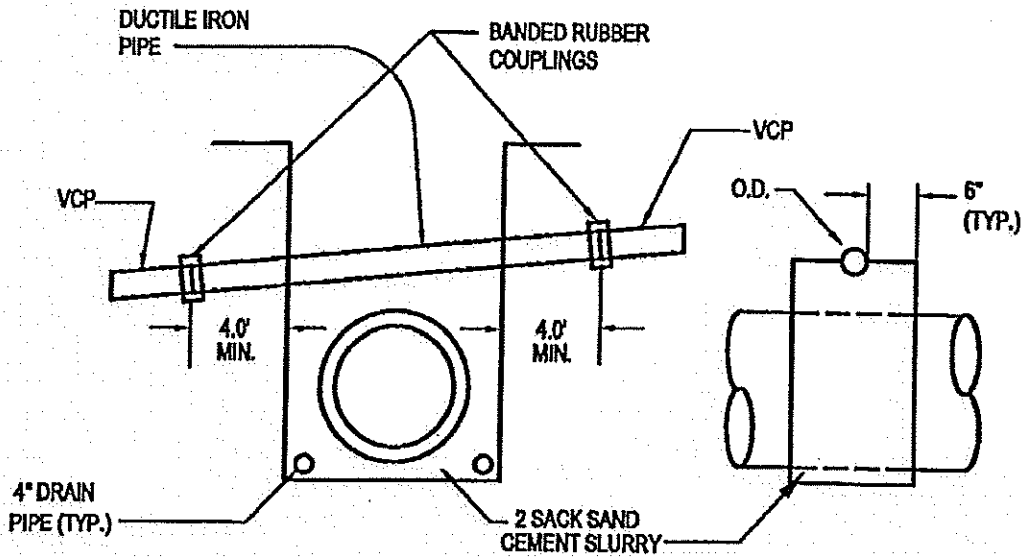

NOTE:

THIS DETAIL MAY BE USED ONLY WITH PRIOR APPROVAL OF THE DISTRICT ENGINEER.

NO.	APPROVED	DATE

MIDWAY CITY SANITARY DISTRICT
WESTMINSTER, CA

Henry Perry 11/21/2010

PIPE SUPPORT
WALL
ACROSS TRENCHES

NO SCALE
STANDARD DIAG.
S-021

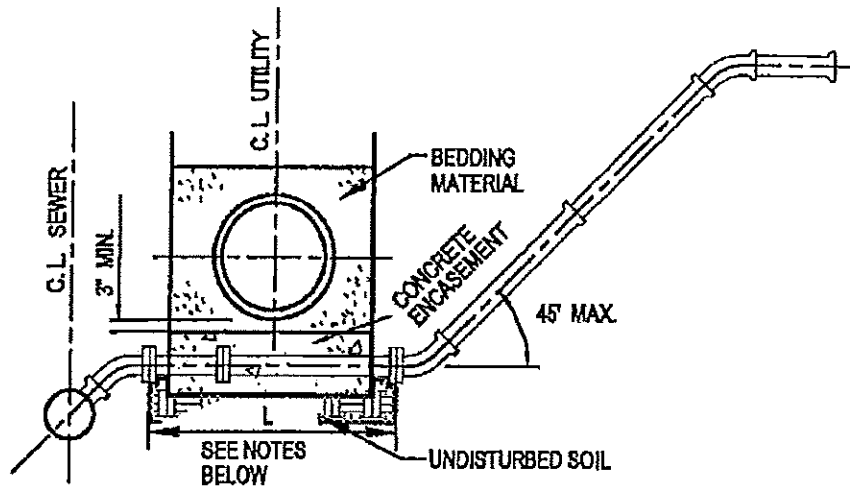

TYPE I

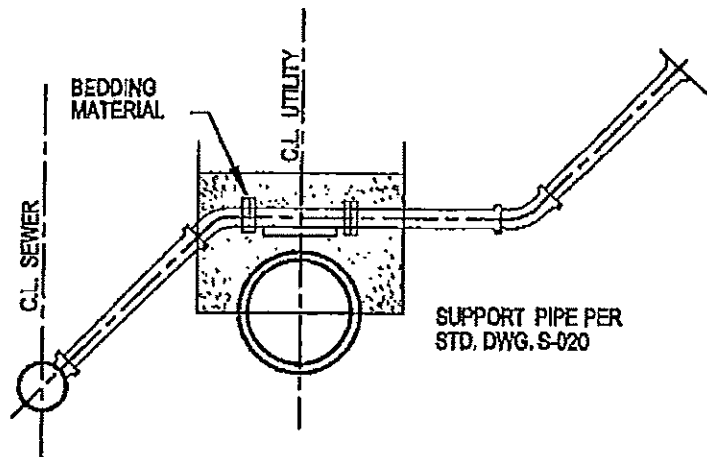

TYPE II

NOTES:

1. ANY OTHER PROPOSED DESIGN SHALL HAVE THE DISTRICT ENGINEER'S APPROVAL PRIOR TO THE START OF CONSTRUCTION.
2. MINIMUM SLOPE FOR SEWER LATERAL SHALL BE 1/4" PER FOOT.
3. L= WIDTH OF STORM DRAIN TRENCH PLUS EXTENSION AT BOTH SIDES TO FIRST PIPE JOINT AT OR BEYOND TRENCH.
4. LATERALS SHALL HAVE A MINIMUM OF 5' OF COVER AT THE PROPERTY LINE.
5. ALL ENCASED SEWER PIPE SHALL BE DUCTILE IRON WITH BANDED RUBBER COUPLINGS.
6. ALL ENCASEMENTS SHALL BE CLASS 'A' CONCRETE.

NO.	APPROVED	DATE

MOWAY CITY SANITARY DISTRICT
WESTMINSTER, CA

Handwritten signature and date: 11/2/2010

SEWER HOUSE
LATERAL AT
UTILITY INTERSECTIONS

NO SCALE
STANDARD DWG.
S-022

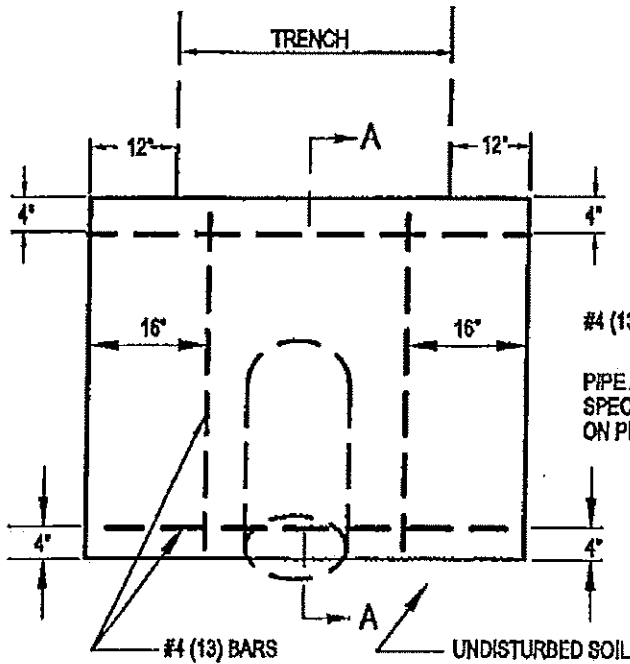

ELEVATION

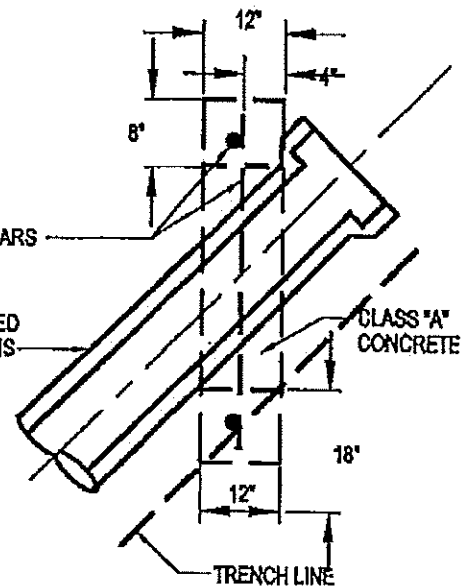

SECTION A-A

NOTES:

1. PIPE ANCHOR BLOCKS SHALL BE INSTALLED ON ALL SEWERS WHERE THE SLOPE EXCEEDS 30%.
2. SPACING SHALL BE 100' ON CENTER WHERE SLOPES ARE 30% TO 50%, 75' ON CENTER WHERE SLOPES ARE 51% TO 70% AND 50' ON CENTER WHERE SLOPES ARE 71% AND GREATER.
3. THE ENGINEER MAY REQUIRE DUCTILE IRON PIPE WITH MECHANICAL JOINTS IN LIEU OF ANCHOR BLOCKS.

() DENOTES METRIC SYSTEM.

NO.	APPROVED	DATE

MIDWAY CITY SANITARY DISTRICT
WESTMINSTER, CA
[Signature] 11/21/2010

ANCHOR
BLOCK
DETAIL

NO SCALE
STANDARD DWG.
S-023

V.C.P. SIZE	MIN. CASING SIZE	MIN. WALL THICKNESS
6"	16" I.D.	1/4"
8"	18" I.D.	1/4"
10"	21" I.D.	5/16"
12"	24" I.D.	5/16"

P.V.C. SIZE	MIN. CASING SIZE	MIN. WALL THICKNESS
6"	12" I.D.	1/4"
8"	16" I.D.	1/4"
10"	18" I.D.	5/16"
12"	20" I.D.	5/16"

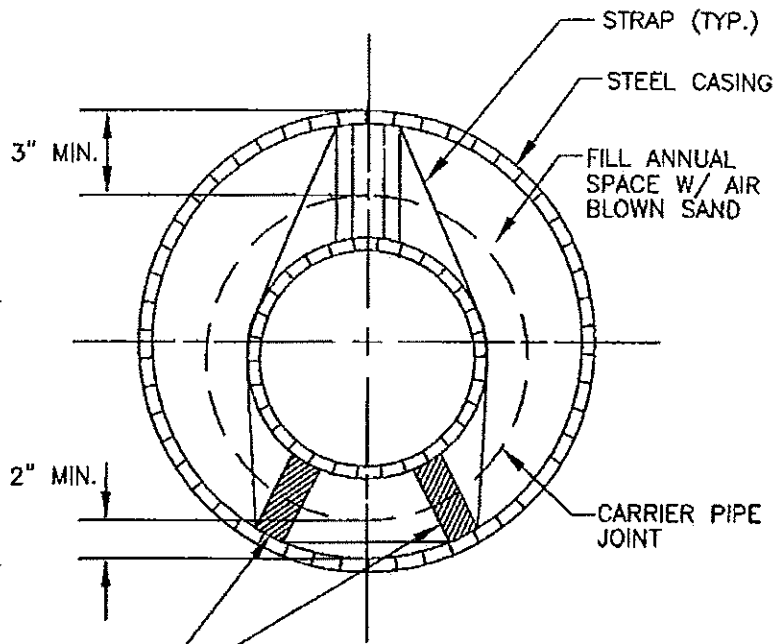

FOR EACH LENGTH OF PIPE, 3' LONG 4" X 4" SKIDS BEVELED AT BOTH ENDS, SHALL BE STRAPPED IN PLACE 3" FROM EACH END OF PIPE. NOTCH SKID TO SEAT STRAP. STRAP SHALL BE 316 STAINLESS STEEL.

NOTES:

1. UNLESS NOTED OTHERWISE, CASING SHALL BE INSTALLED BY THE BORE, JACK AND/OR TUNNEL METHOD.
2. SIZE AND THICKNESS OF CASING SHALL BE AS SHOWN IN SCHEDULE.
3. ALL STEEL CASING PIPE FIELD JOINTS SHALL BE WELDED FULL-CIRCUMFERENCE.
4. UNFINISHED 4" X 4" REDWOOD SKIDS SHALL BE PROVIDED PER DETAIL ABOVE.
5. CARRIER PIPE SHALL BE AIR PRESSURE TESTED PRIOR TO FILLING CASING.
6. UPSTREAM AND DOWNSTREAM ELEVATIONS OF CARRIER PIPE TO BE VERIFIED PRIOR TO FILLING.
7. EACH END OF CASING SHALL BE SEALED WITH CONCRETE MORTAR.
8. INSTALL GROUT CONNECTIONS TO CASING AND GROUT TO FILL ALL VOIDS.

MIDWAY CITY SANITARY DISTRICT
WESTMINSTER, CALIFORNIA

Handwritten signature and date: 11/21/2010

STEEL PIPE CASING

NO SCALE

STANDARD DWG.

S-030A

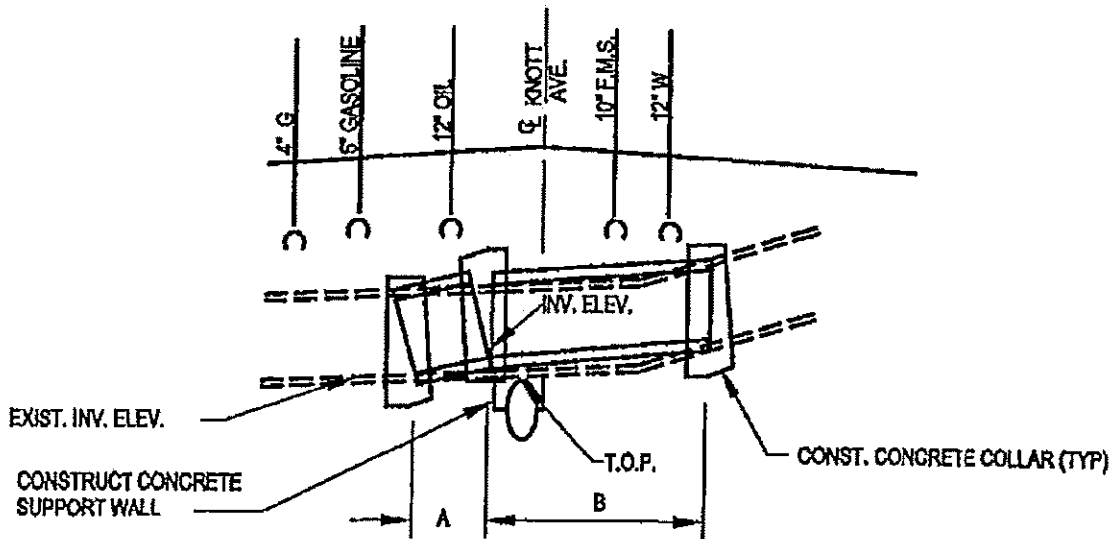

TYPICAL PROFILE
NO SCALE

NOTES:

1. A CONCRETE COLLAR IS REQUIRED WHERE THE CHANGE IN GRADE EXCEEDS 0.10 FEET PER FOOT.
2. WHERE PIPES OF DIFFERENT DIAMETERS ARE JOINED WITH A CONCRETE COLLAR, L AND T SHALL BE THOSE OF THE LARGER PIPE $D=D_1$ OR D_2 , WHICHEVER IS GREATER.
3. FOR PIPE SIZE NOT LISTED USE NEXT SIZE LARGER.
4. OMIT REINFORCING ON PIPES 24" AND LESS IN DIAMETER AND ON ALL PIPES WHERE ANGLE CHANGE IS LESS THAN 0.10 FEET PER FOOT.
5. WHERE REINFORCING IS REQUIRED THE DIAMETER OF THE CIRCULAR TIES SHALL BE $D + (2 \times \text{WALL THICKNESS}) + 8$.
6. WHEN D_1 IS EQUAL TO OR LESS THAN D_2 , JOIN INVERTS AND WHEN D_1 IS GREATER THAN D_2 , JOIN SOFFITS.
7. NOT TO BE USED FOR A SIZE CHANGE ON THE MAINLINE.
8. USE CLASS "A" CONCRETE.
9. DIMENSIONS A,B, ELEVATIONS AND SLOPES ($S=0.00\%$) SHALL BE SHOWN ON THE PLANS.
10. THE INSIDE OF THE FIELD CLOSURE SHALL BE BARREL FORMED UTILIZING T-LOCK PVC AND ANGLE TURNBACKS AT EDGES, CAULK EDGES OF PVC.

() DENOTES METRIC SYSTEM

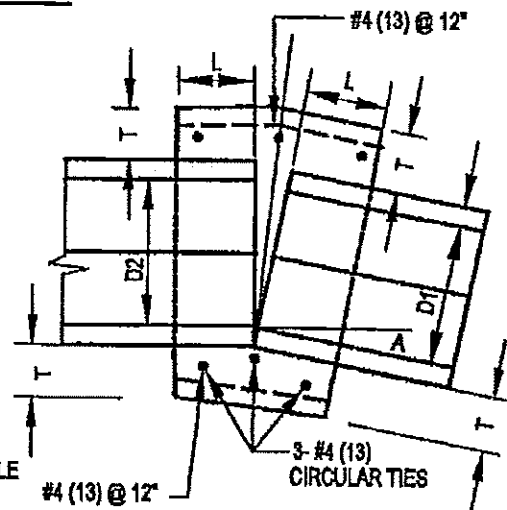

TYPICAL CONCRETE COLLAR
NO SCALE

D	L	T
12"	1.0"	4"
18"	1.0"	5"
24"	1.0"	6"
36"	1.5"	8"
42"	1.5"	9"

NO.	APPROVED	DATE

MIDWAY CITY SANITARY DISTRICT
WESTMINSTER, CA

[Signature] 11/2/2006

FIELD CLOSURE
FOR
V.C.P.

NO SCALE
STANDARD DWG.
S-040

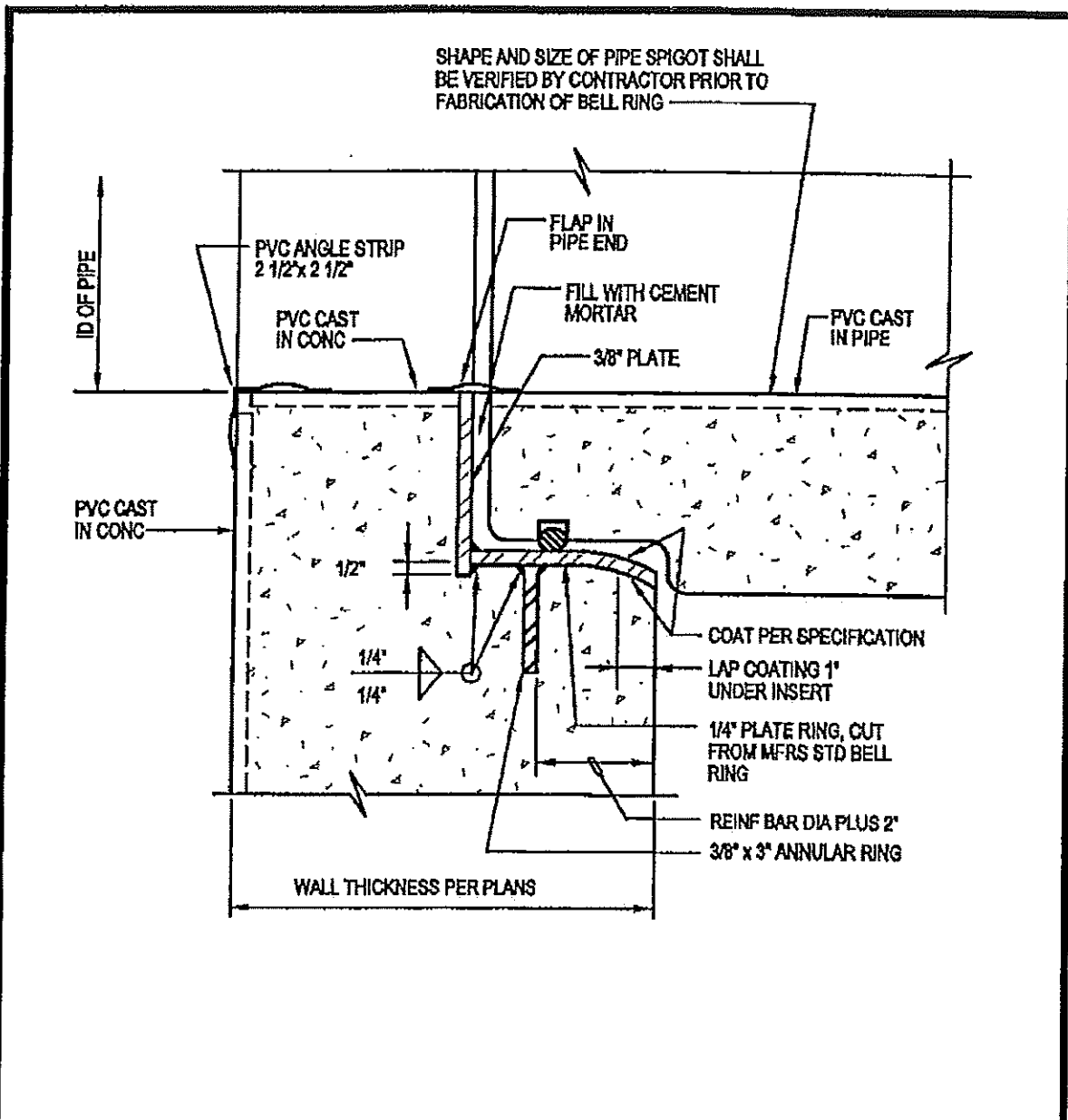

NOTES:

1. WELD ALL CUT REINFORCING BARS TO ANNULAR RING FOR PIPES GREATER THAN 48" DIAMETER. USE LOW HYDROGEN WELDING ER 70XX.
2. GRIND SMOOTH ALL METAL EDGES IN AREAS TO BE COATED AND ALL SURFACES IN PIPE SEATING AREA.
3. RING SHALL HAVE SPIDER BRACING INSTALLED AT POINT OF MANUFACTURE.
4. ALL WELDS SHALL BE DYE TESTED PRIOR TO SHIPMENT.

NO.	APPROVED	DATE

MIDWAY CITY SANITARY DISTRICT
WESTMINSTER, CA
Handwritten signature and date: 11/2/00

BELL RING INSERT
WITH PVC
PLATE LINER

NO SCALE
STANDARD DHD3
S-044

FRAME AND COVER
PER DWG. S-053

3/4" TO 1"
A.C. PAVING

CLASS "B"
CONCRETE COLLAR

1" MASTIC
JOINT (TYP.)

FACTORY
PLUG

BRICK & MORTAR PLUG

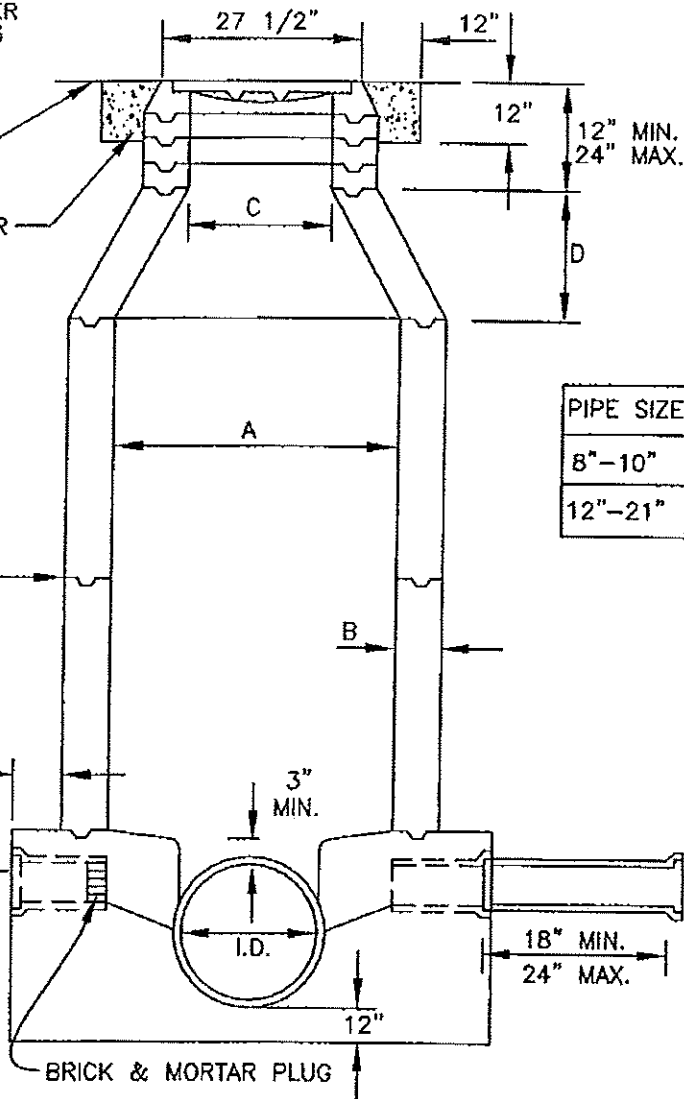

PIPE SIZE	A	B	C	D
8"-10"	48"	6"	24"	24"
12"-21"	60"	8"	36"	24"

NOTES:

1. NO STEPS ARE ALLOWED IN ANY MANHOLE. ALL SHAFTS AND CONES SHALL BE PRECAST. ECCENTRIC CONE SHALL BE SET WITH STRAIGHT SIDE ON THE DOWNSTREAM SIDE OF THE MANHOLE. SHAFT AND CONE MAY BE REINFORCED OR NON-REINFORCED.
2. MANHOLE BASE SHALL BE POURED WITH CLASS "A" CONCRETE.
3. SIDES OF BASE SHALL BE EITHER FORMED OR POURED AGAINST VERTICAL SMOOTH EARTH.
4. CROWN OF LATERAL SHALL MATCH CROWN OF MAIN.
5. MANHOLE PLACED IN UNPAVED AREAS SHALL HAVE THEIR FRAMES AND COVERS SET TO 18" ABOVE FINISHED GRADE.
6. WHEN THE DEPTH OF MANHOLE EXCEEDS 15' FROM THE TOP OF PIPE TO FINISHED GRADE THE MANHOLE SHAFT SHALL BE INCREASED TO A DIAMETER OF 60".

MIDWAY CITY SANITARY DISTRICT
WESTMINSTER, CALIFORNIA

Handwritten signature and date: 11/2/2010

UN-LINED MANHOLE
FOR SEWERS

NO SCALE

STANDARD DWG.

S-045A

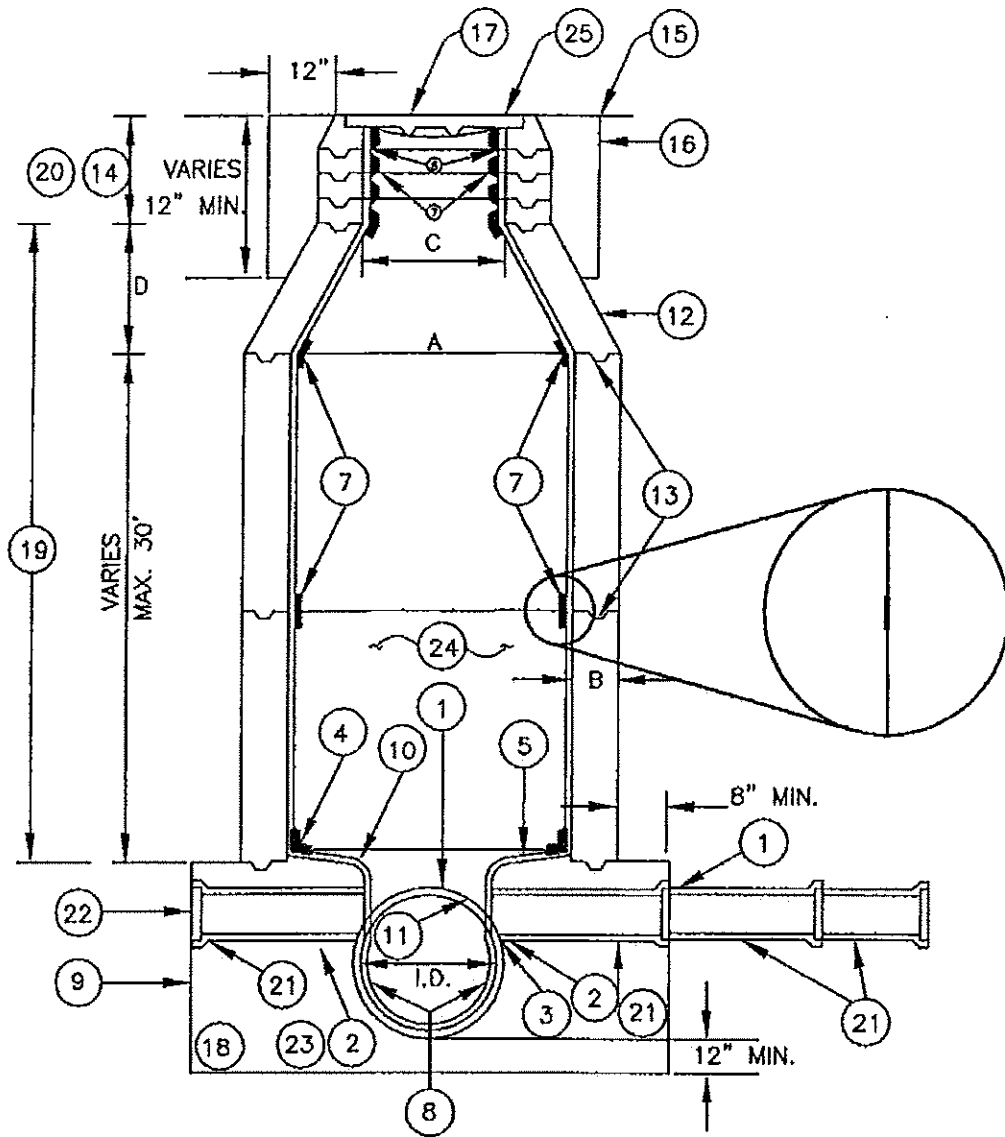

NOTES:

SEE DETAIL S-050A SHEET 3 OF 3
FOR DIMENSION TABLE.

MIDWAY CITY SANITARY DISTRICT
WESTMINSTER, CALIFORNIA

Handwritten signature and date: 11/2/2010

PVC-LINED MANHOLE
FOR SEWERS
SHEET 1 OF 3

NO SCALE

STANDARD DWG.

S-050A

NOTES:

- ① LATERAL SOFFIT SHALL MATCH SOFFIT OF TRUNK SEWER. SEE NOTE 21.
- ② PVC TURNBACK ON VCP SHALL BE A MINIMUM OF 6" PER S-056.
- ③ PVC LINER PLATE SHALL BE HELD TIGHT TO OUTSIDE SURFACE OF VCP BY 1/2" STAINLESS STEEL BAND WITH CONTACT CEMENT ADHESIVE APPLIED TO BOTH SURFACES PER S-056.
- ④ PREFORMED CORNER WELD STRIP TO BE INSTALLED.
- ⑤ INSTALL NON-SKID SURFACE ON COMPLETE MANHOLE SHELF, BOTH SIDES OF MAIN CHANNEL PER THE STANDARD SPECIFICATIONS.
- ⑥ INSTALL CONTINUOUS PREFORMED CORNER PVC ANGLES UNDER FRAME.
- ⑦ PVC WELD STRIPS.
- ⑧ COMPLETE CONCRETE CHANNEL SHALL BE CONSTRUCTED WITH FORMS AND PVC LINED, WHERE PVC LINED RCP IS USED. THE CHANNEL LINING IS TO BE INSTALLED TO THE SAME DEPTH AS THE RCP LINING.
- ⑨ SIDES OF BASE TO BE EITHER FORMED OR Poured NEAT AGAINST UNDISTURBED EARTH. BASE MAY BE EITHER CIRCULAR OR RECTANGULAR.
- ⑩ MANHOLE SHELVES TO BE SLOPED 1" PER FT. TO CHANNEL
- ⑪ ALL LATERAL INLETS 12" DIAMETER AND SMALLER SHALL HAVE PVC WELDED GAS FLAPS INSTALLED PER DRAWING NO. S-056.
- ⑫ ECCENTRIC CONE TO BE SET WITH STRAIGHT SIDE ON DOWNSTREAM SIDE OF MANHOLE FOR MAINTENANCE PURPOSES. ECCENTRIC REINFORCED CONCRETE FLAT TOPS MAY BE USED WHEN APPROVED BY THE ENGINEER THRU SUBMITTAL REVIEW.
- ⑬ 2 WRAPS OF RAM NECK OR APPROVED EQUAL SEALANT. THE SEAL STRIPS SHALL BE PLACED ON SHOULDER OF GROOVE. STEPS ARE NOT ALLOWED IN ANY MANHOLE.
- ⑭ DISTANCE FROM TOP OF CONE TO TOP OF FRAME AND COVER SHALL NOT BE LESS THAN 12" OR MORE THAN 24". ALL GRADE RINGS SHALL BE REINFORCED CLASS V CONCRETE WITH PRECAST PVC LINER PLATE ON INSIDE.
- ⑮ FOR 1" AC PAVING, CONTRACTOR OR DESIGNER SHALL VERIFY WITH LOCAL CITY REQUIREMENTS. SEE S-055.
- ⑯ CONCRETE COLLAR SEE S-055.
- ⑰ FRAME AND COVER PER DRAWING NO. S-053A, S-054-A OR S-055.
- ⑱ MANHOLES 72" AND LARGER SHALL HAVE CLASS "A" CONCRETE BASES W/ #8 (19) @ 12" E.W.
- ⑲ MANHOLES SHALL BE BACKFILLED WITH 1 1/2 SACK SLURRY.

MIDWAY CITY SANITARY DISTRICT
WESTMINSTER, CALIFORNIA

Handwritten signature and date: 11/2/2010

PVC-LINED MANHOLE
FOR SEWERS
SHEET 2 OF 3

NO SCALE

STANDARD DWG.

S-050A

NOTES CONTINUED:

- ⑳ MANHOLES PLACED IN UNPAVED AREAS SHALL HAVE THE COVERS PLACED 18" ABOVE FINISHED GRADE.
- ㉑ ALL MANHOLES SHALL HAVE TWO 8" VCP STUBS SLOPED 1/4" PER FOOT INSTALLED AT 90° TO THE MAIN CHANNEL EXCEPT WHERE THE MAIN CHANNEL MAKES A TURN OF OVER 45°. STUBS SHALL BE 8" MIN. IN DIA. UNLESS OTHERWISE NOTED.
- ㉒ ALL UNUSED CONNECTIONS SHALL HAVE A FACTORY MADE VCP PLUG INSTALLED IN THE BELL END OF THE PIPE AND A BRICK AND MORTAR PLUG IN THE SPIGOT END OF THE CONNECTION TO THE MAIN TRUNK SEWER CHANNEL. EACH VCP CONNECTION TO THE MANHOLE BASE SHALL HAVE TWO EACH, TWO FOOT JOINTS.
- ㉓ PIPE ABOVE SPRING LINE TO BE REMOVED BY SAW CUTTING, REMOVED SECTION SHALL BE THE MANHOLE SHAFT DIAMETER.
- ㉔ INSTALLATION OF P.V.C. LINER PLATE SHALL CONFORM TO THE REQUIREMENTS OF SECTION 06620 OF THE MASTER SPECIFICATIONS OF THE ORANGE COUNTY SANITATION DISTRICT.
- ㉕ SEAL MANHOLE COVERS AS PER SPECIFICATIONS FOR MINIMIZING ODOR OR INFLOW.
- ㉖ VACUUM TESTING SHALL BE PERFORMED PER ASTM C-1224 UNO.

○ DENOTES REINFORCED CROSS SECTION
 ○○ DENOTES BASE MUST BE REINFORCED CONCRETE

PIPE SIZE	A	B	C	D
8"-10"	48"	8"	26"	24"
		6"		
12"-24"	60"	8"	36"	24"
		6"		

MIDWAY CITY SANITARY DISTRICT
 WESTMINSTER, CALIFORNIA
[Signature] 11/21/2010

PVC-LINED MANHOLE
 FOR SEWERS
 SHEET 3 OF 3

NO SCALE
 STANDARD DWG.
 S-050A

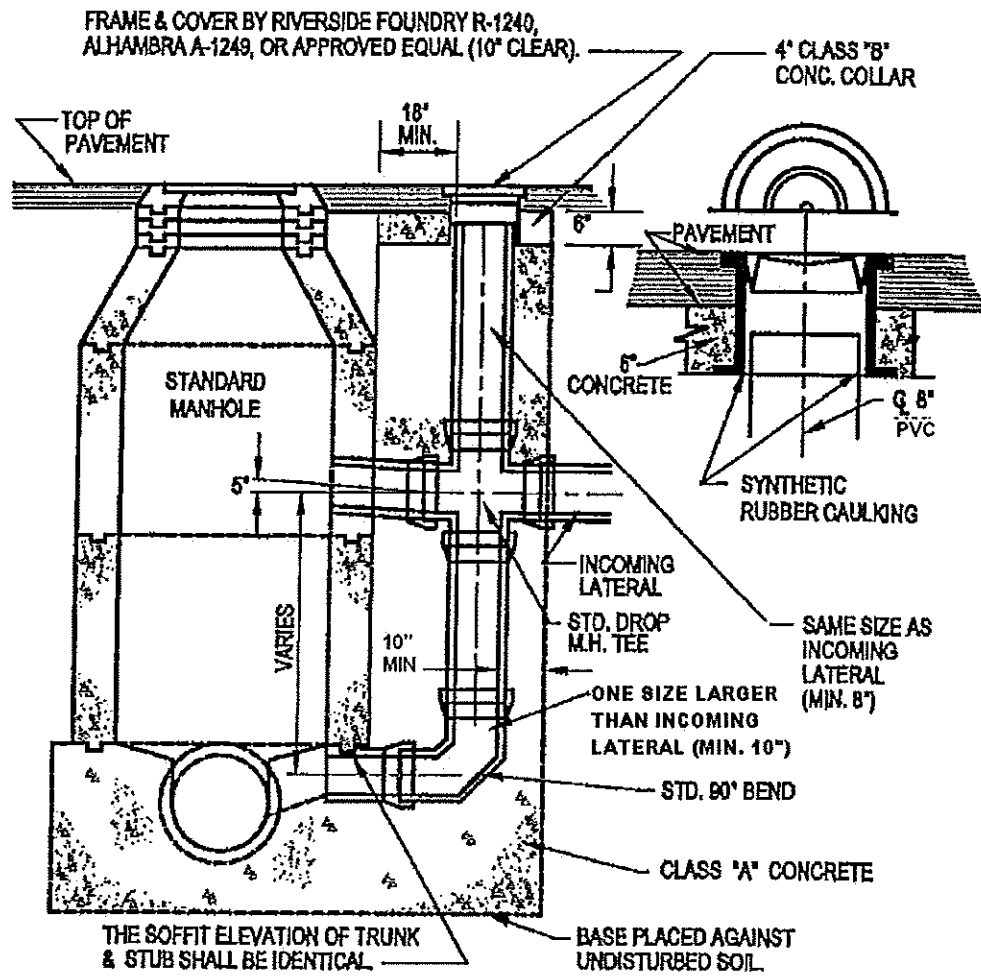

NOTES:

1. SEE DETAIL S-050 FOR STANDARD MANHOLE.
2. CONCRETE FOR DROP SECTIONS SHALL BE FORMED.
3. ALL MANHOLE PENETRATIONS SHALL BE MADE BY CORE DRILLING.
4. DROP MANHOLE CONNECTION SHALL BE USED ONLY WHERE SLOPE OF LATERAL INCOMING TO MAIN SEWER WOULD EXCEED 10% AND WITH APPROVAL OF THE THE ENGINEER AND SPECIAL PERMISSION ONLY.

NO.	APPROVED	DATE

MIDWAY CITY SANITARY DISTRICT
WESTMINSTER, CA

[Signature] 11/21/2010

**DROP MANHOLE
CONNECTION TO
STANDARD MANHOLE**

NO SCALE
STANDARD DRG.
S-051

DIAMOND TREAD PATTERN

3" LETTERS (TYP.)

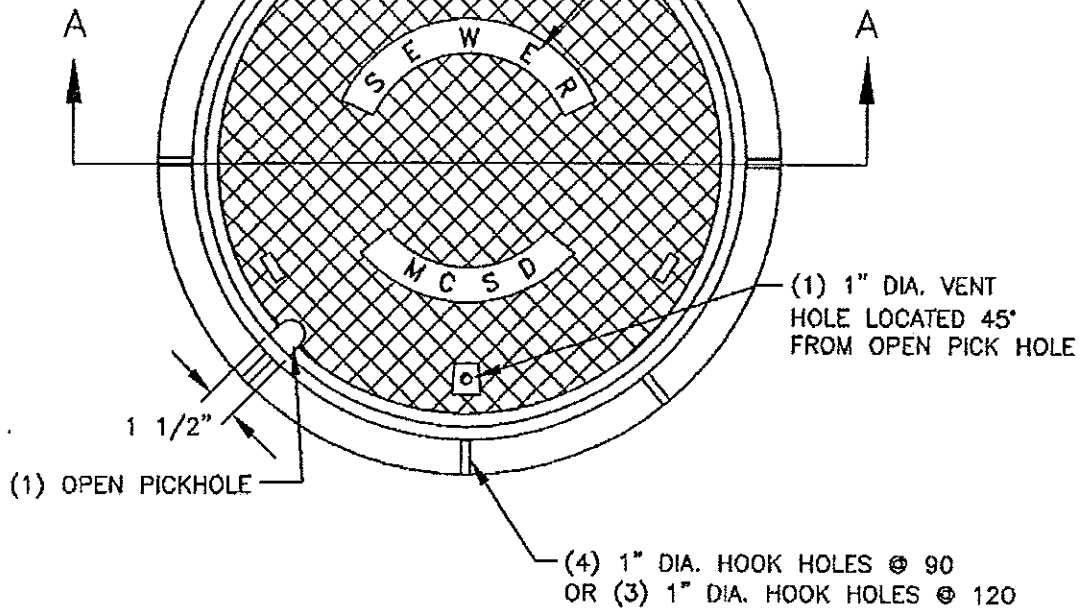

PLAN

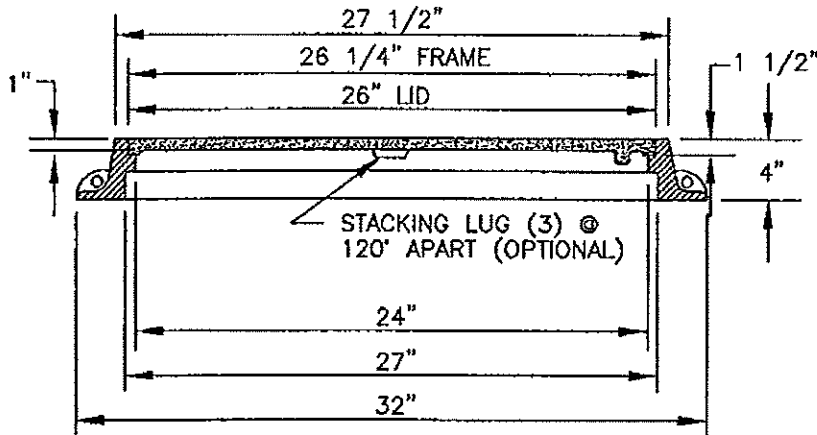

SECTION A-A

NOTE:

- COVERS SHALL BE TRAFFIC GRADE ALHAMBRA A-1270 OR APPROVED EQUAL. ALL CASTINGS SHALL BE COMPLETELY PAINTED WITH 6 MILS. "COAL TAR EPOXY" OR ASPHALT EMULSION, AND LETTERED "MADE IN COUNTRY OF ORGIN", MARKED WITH MANUFACTURER'S IDENTIFICATION "HEAT NO. ____", "ASTM A-48", AND "CLASS 35B IRON" ON UNDERSIDE OF COVER WEIGHT OF COVER SHALL BE 300 LBS. MIN.*, WEIGHT OF FRAME SHALL BE 275 LBS. MIN.* *ACTUAL WEIGHTS SHALL BE BETWEEN 95-110% MINIMUM.

MIDWAY CITY SANITARY DISTRICT
WESTMINSTER, CALIFORNIA

Handwritten signature and date: 11/2/2010

STANDARD MANHOLE
FRAME AND COVER

NO SCALE

STANDARD DWG.

S-053A

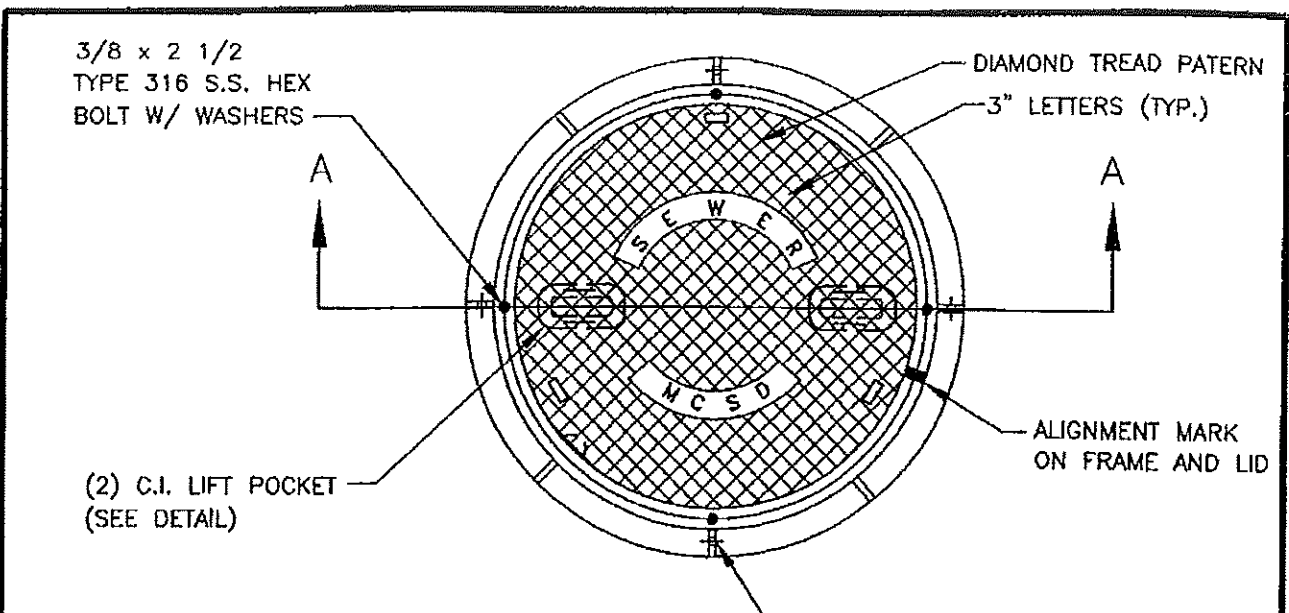

PLAN

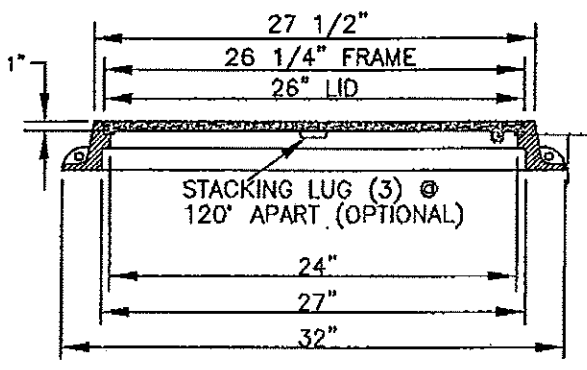

SECTION A-A

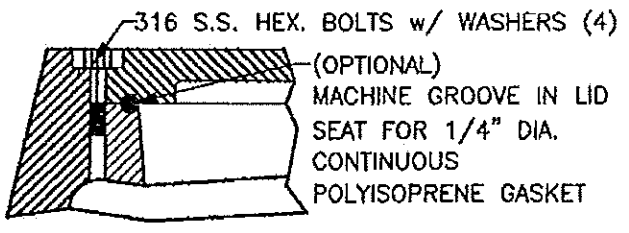

BOLTING/ SELF-SEAL DETAIL

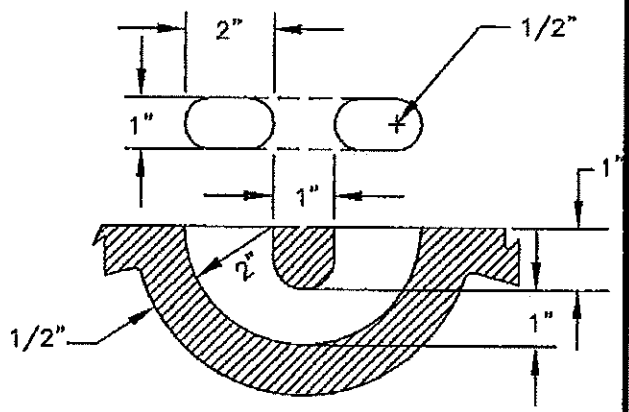

C.I. LIFT POCKET DETAIL

NOTE:

- COVERS SHALL BE TRAFFIC GRADE.
ALL CASTINGS SHALL BE COMPLETELY PAINTED WITH 6 MILS. "COAL TAR EPOXY" OR ASPHALT EMULSION, AND LETTERED "MADE IN COUNTRY OF ORIGIN", MARKED WITH MANUFACTURER'S IDENTIFICATION "HEAT NO. ___", "ASTM A-48", AND "CLASS 35B IRON" ON UNDERSIDE OF COVER. WEIGHT OF COVER SHALL BE 300 LBS. MIN.*, WEIGHT OF FRAME SHALL BE 275 LBS. MIN.*
*ACTUAL WEIGHTS SHALL BE BETWEEN 95-110% MINIMUM.
- BOLTED COVERS SHALL BE INSTALLED AT ALL INTERSECTIONS.

MIDWAY CITY SANITARY DISTRICT WESTMINSTER, CALIFORNIA	BOLTED MANHOLE FRAME AND COVER	NO SCALE
<i>Kevin J. Ruff</i> 11/2/2010		STANDARD DWG. S-054A

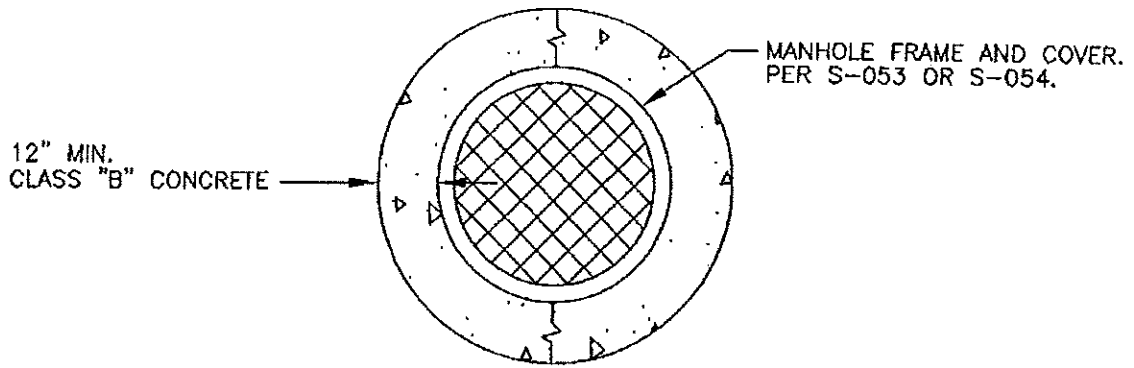

PLAN

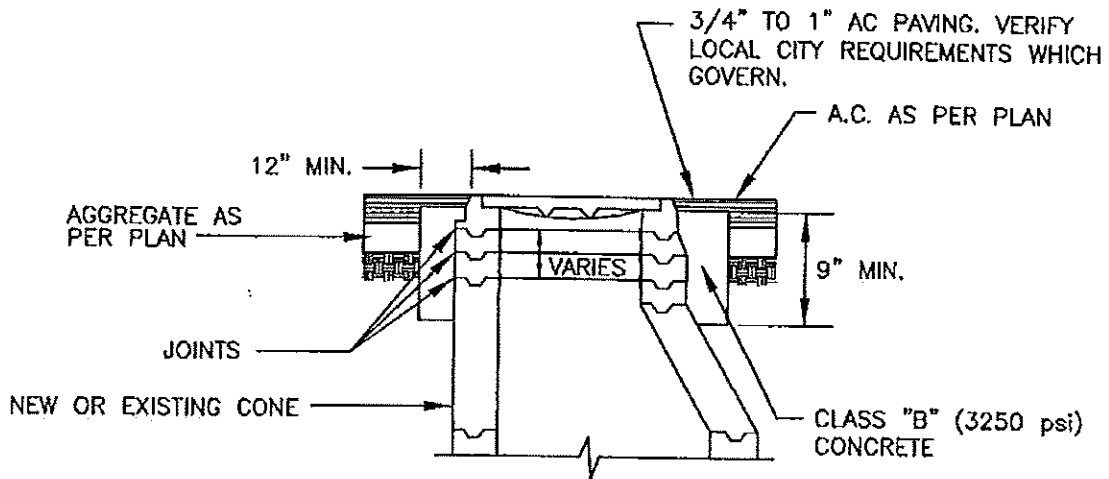

CROSS SECTION

NOTES:

1. ALL AGGREGATE BASE REMOVED SHALL BE REPLACED WITH CLASS B CONCRETE.
2. CONCRETE MAY BE CIRCULAR OR SQUARE IN SHAPE WITH A MINIMUM OF 12" BETWEEN EDGE OF CONCRETE AND LIP OF MANHOLE FRAME.
3. MANHOLE MAY BE ADJUSTED TO GRADE USING MORTAR OR PRECAST RINGS. SET FLUSH TO 1/8" HIGH (MAXIMUM).
4. REPAIR PVC OR OTHER LINING, IN KIND.
5. SEAL MANHOLE COVERS AS PER SPECIFICATIONS.
6. REPAIR OR REPLACE MANHOLE LINING IN KIND PER SPECIFICATIONS.

COMPRESSIVE STRENGTH AT 28 DAYS (PSI)	3,250
CEMENT FACTOR MINIMUM (SACK/CU. YD)	5.50
WATER CEMENT RATIO MAXIMUM (GALLONS/SACK)	6.50

MIDWAY CITY SANITARY DISTRICT
WESTMINSTER, CALIFORNIA

Handwritten signature and date: 11/2/2010

MANHOLE ADJUSTMENT
TO GRADE

NO SCALE
STANDARD DWG.
S-055A

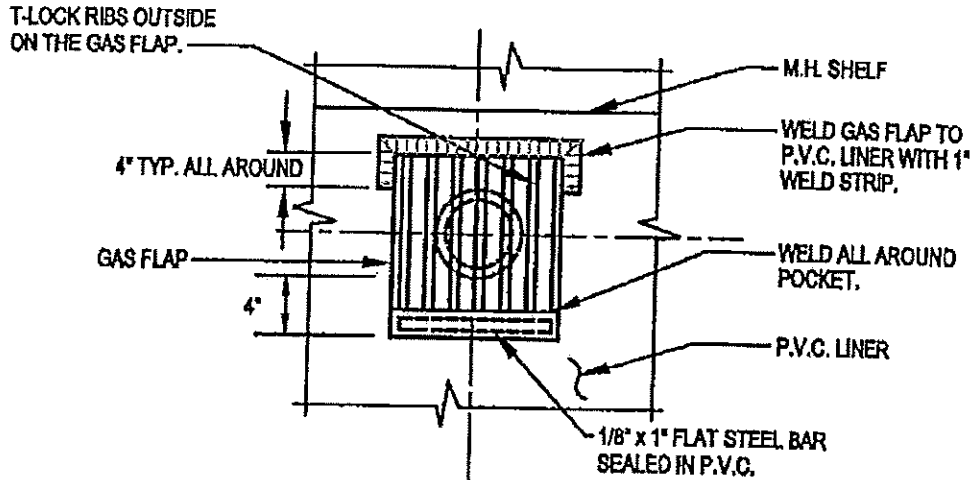

VIEW C-C
NOT TO SCALE

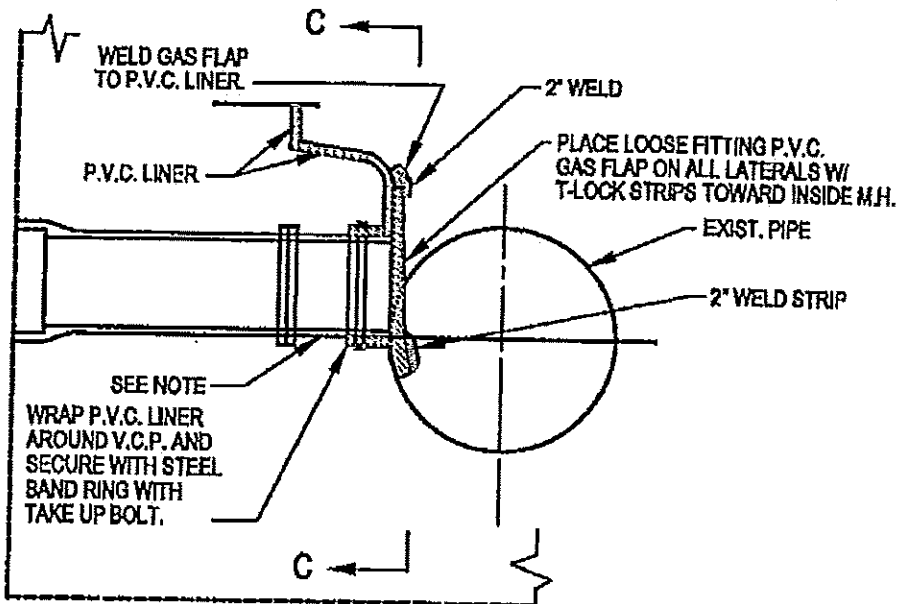

NOTES:

1. FOR INSTALLATION AT EXISTING M.H. REMOVE INTERFERING CONCRETE AT END OF EACH LATERAL AND EXTEND VCP AS SHOWN. GROUT IN PLACE. EXTEND PVC M.H. LINER OVER GROUT AND INSTALL GAS FLAP AS SHOWN.
2. FOR MANHOLES WITHOUT PVC LINER, ATTACH GAS FLAP WITH 1/4" x 1" ST. STL. FLAT BAR AND 3 ST. STL. CA.
3. PROVIDE GAS FLAPS FOR ALL LATERALS 12" AND LESS, UNLESS OTHERWISE SPECIFIED.

NO.	APPROVED	DATE

MOWAY CITY SANITARY DISTRICT
WESTMINSTER, CA
[Signature] 11/21/2010

P.V.C. LINER AND GAS
FLAP INSTALLATION
AT LATERALS

NO SCALE
STANDARD DWG.
S-056

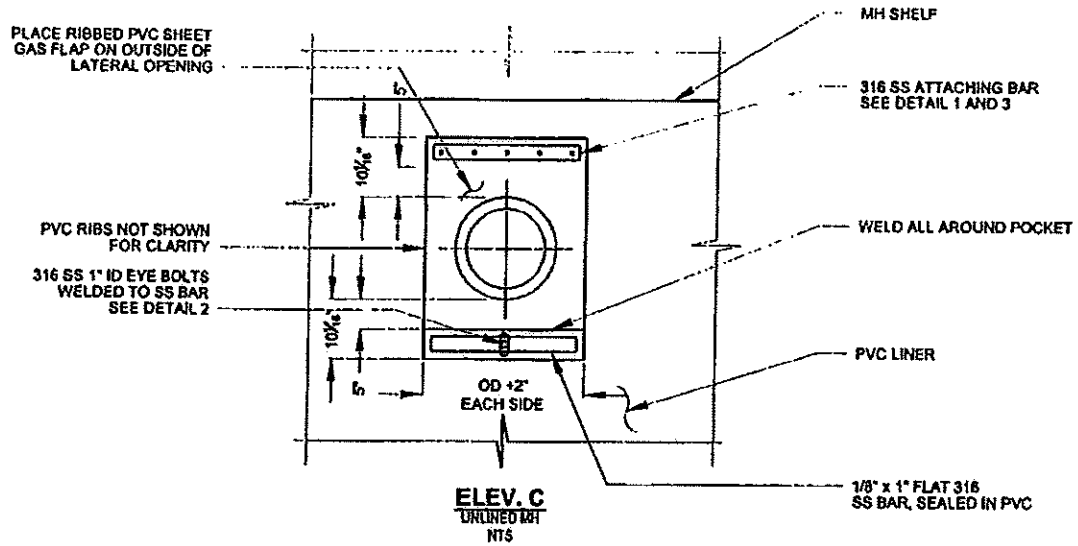

NOTES:

1. FOR INSTALLATION AT EXISTING MH., SEE STD DWG. S-057
2. FOR MANHOLES WITHOUT PVC LINER, ATTACH GAS FLAP W/ 1/4" x 1" 316 SS FLAT BAR. DRILL HOLES 1/2" FROM EACH END AND ONE IN THE CENTER. (A = 3" OR LESS) SPACE OTHER HOLES 3" OR LESS
3. PROVIDE GAS FLAP FOR ALL LATERALS 12" AND LESS, UNLESS OTHERWISE SPECIFIED.

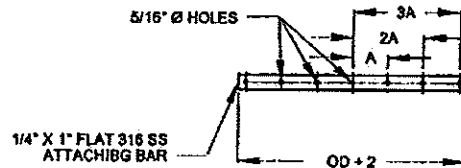

DETAIL 3
ATTACHING BAR SEE NOTE 2

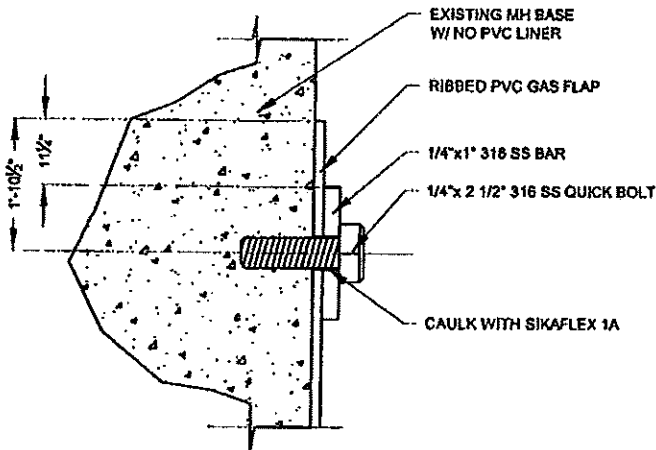

DETAIL 1
NTS

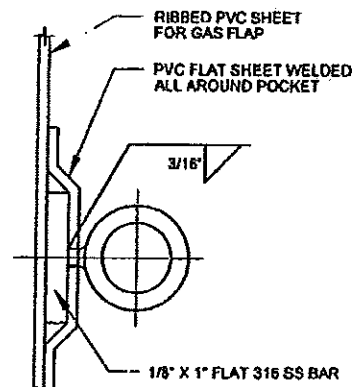

DETAIL 2
NTS

			MEHAY CITY SANITARY DISTRICT WESTMINSTER, CALIFORNIA	GAS FLAP INSTALLATION FOR UNPVC LINED OR UNLINED MANHOLES	STANDARD DWG.
1 NO.	MST APPROVED	 DATE	<i>Thuy Phung</i> 11/20/2010		S-057

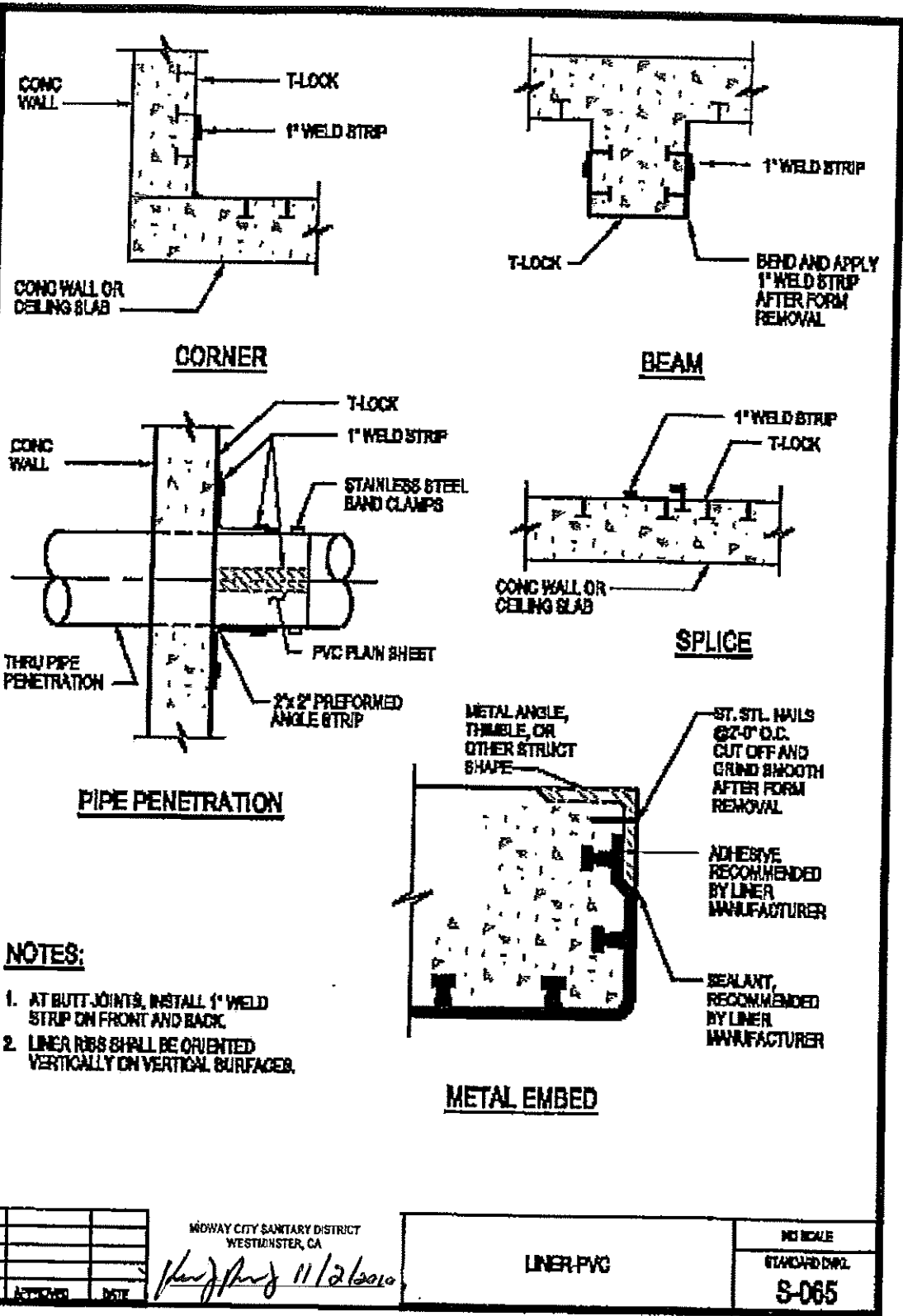

NOTES:

1. AT BUTT JOINTS, INSTALL 1" WELD STRIP ON FRONT AND BACK.
2. LINER RIBS SHALL BE ORIENTED VERTICALLY ON VERTICAL SURFACES.

MOWAY CITY SANITARY DISTRICT
WESTMINSTER, CA

[Signature] 11/2/2010

LINER-PVC

NO SCALE
STANDARD DWG.
S-065

THE BELL ON THE COLLAR TEE SADDLE SHALL NOT BE ENCASED IN CONCRETE. TAP SHALL BE MADE AT THE APPROXIMATE CENTERLINE OF THE JOINT. ENCASE 12" EACH SIDE OF OPENING.

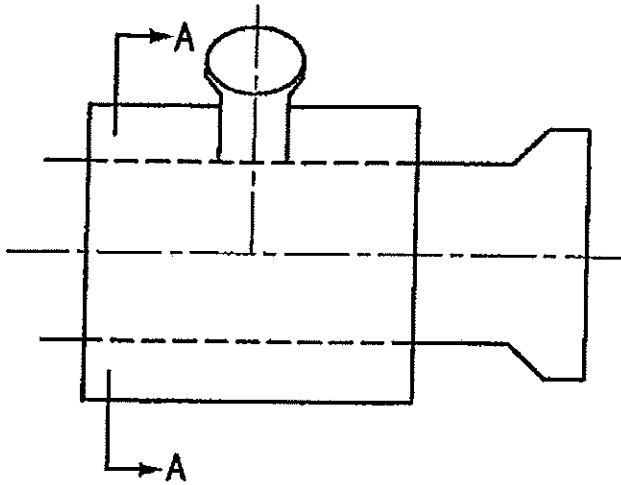

ELEVATION

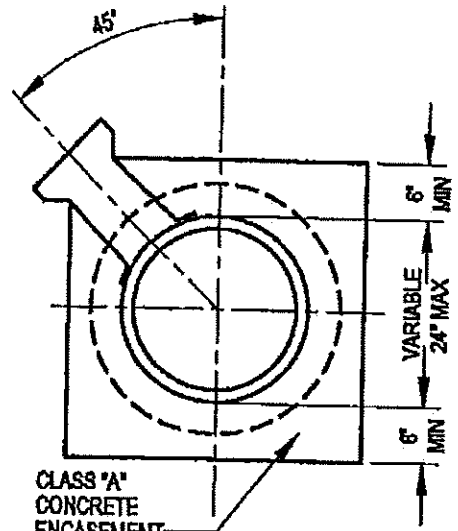

CLASS "A"
CONCRETE
ENCASEMENT

SECTION A-A

NOTE:

SADDLE CONNECTIONS SHALL NOT BE MADE TO SEWERS LARGER THAN 8" I.D.

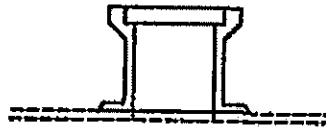

COLLAR TEE SADDLE

(AS PROVIDED BY MANUFACTURER)

NOTES:

1. THE CONTRACTOR SHALL SECURE THE COLLAR TEE SADDLE TO THE SEWER WITH AN EPOXY RESIN PROVIDED BY THE PIPE MANUFACTURER.
2. THE CONTRACTOR SHALL ENCASE THE SADDLE CONNECTION WITH CLASS "A" CONCRETE AFTER THE CONNECTION IS INSPECTED BY THE ENGINEER.
3. THE CONTRACTOR SHALL KEEP ALL CLAY CHIPS, DIRT, EPOXY, MORTAR AND CONCRETE OUT OF THE SEWER SADDLE, AND PERFORM A CLEANING AND BALLING OF THE SEWER.
4. THE CONTRACTOR SHALL REPAIR OR REPLACE ANY DAMAGED PIPE AS DIRECTED BY THE ENGINEER.
5. SADDLE CONNECTIONS TO SEWERS 8" IN DIAMETER SHALL BE DONE BY CORE DRILL.

NO.	APPROVED	DATE

MIDWAY CITY SANITARY DISTRICT
WESTMINSTER, CA

Henry Henry 11/2/2010

SADDLE CONNECTION

NO SCALE

STANDARD DRG.

S-070

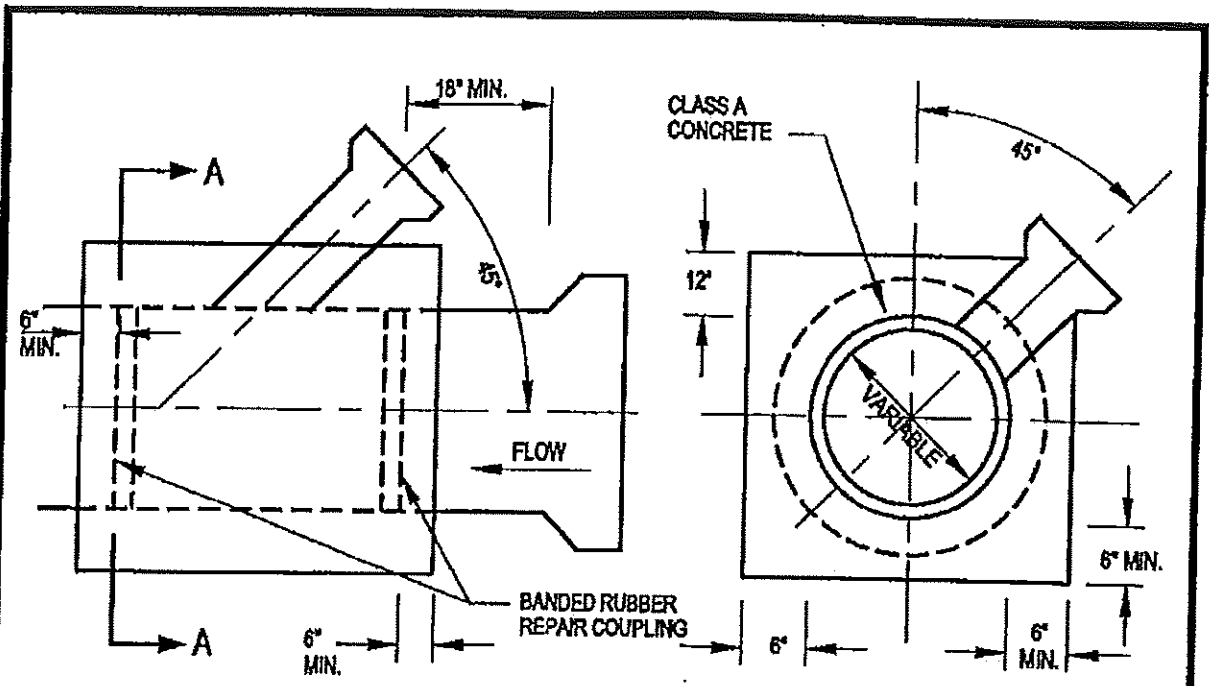

ELEVATION

SECTION A-A

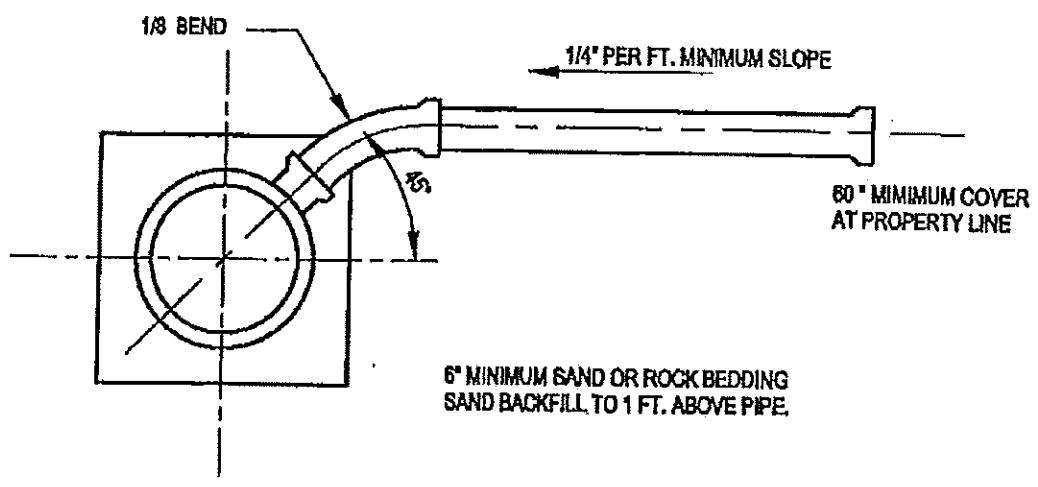

NO.	APPROVED	DATE

MOWAY CITY SANTARY DISTRICT
WESTMINSTER, CA
Pho... 11/2/2010

CUT IN WYE CONNECTION

NO SCALE
STANDARD DWG.
S-071

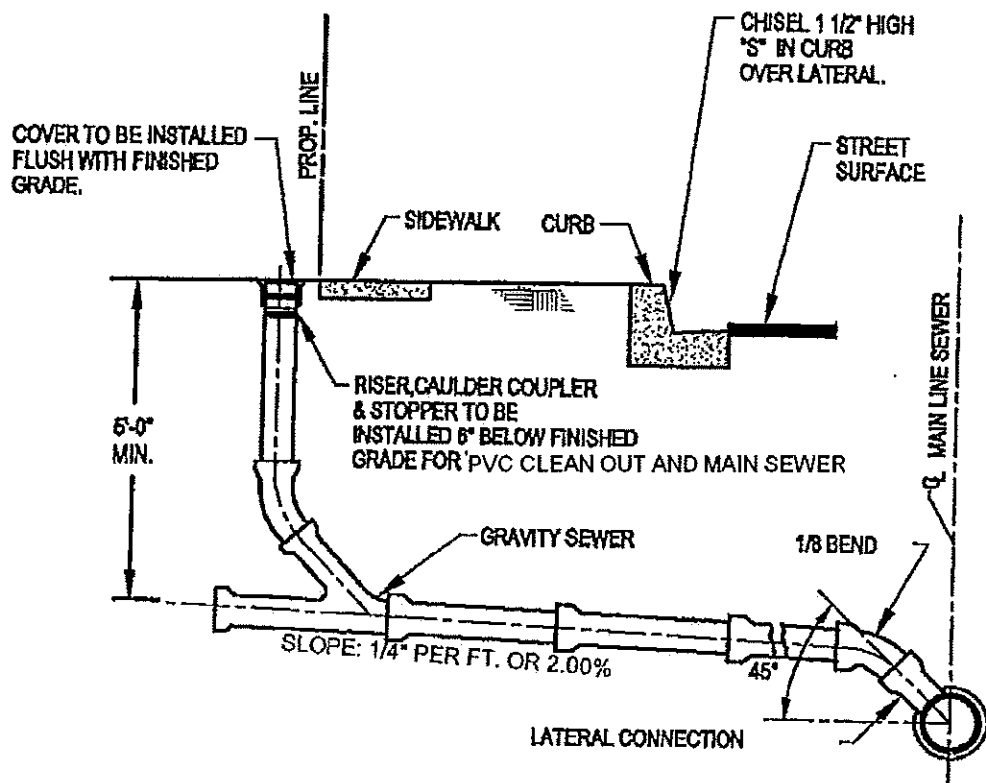

NOTES:

1. FOR SLOPE LESS THAN 1/4" PER FOOT, A 6" CONNECTION SHALL BE USED. MIN. SLOPE = 1/8" PER FT.
2. SEWER CLEANOUT SHALL INCLUDE A STOPPER OVER RISERS.
3. FOR SEWER CLEANOUT RISER USE PIPE OF THE SAME DIAMETER AND MATERIAL USED IN THE ADJOINING SEWER LINE.
4. SINGLE FAMILY RESIDENCES SHALL BE 4" GRAVITY SEWERS. ALL OTHERS SHALL BE 6" OR MORE.
5. A CLEANOUT SHALL BE INSTALLED ON ALL HOUSE CONNECTIONS.
6. GRAVEL OR CRUSHED ROCK BEDDING TO SPRING LINE OF WYE AND 1 FOOT EACH SIDE OF LATERAL.

NO.	APPROVED	DATE

MIDWAY CITY SANITARY DISTRICT
WESTMINSTER, CA

[Signature] 11/2/2010

HOUSE LATERAL, TYPICAL

NO SCALE
STANDARD DWG.
S-072

**LAWPHOLE COVER AND FRAME
FOR SEWER LINE INSPECTION AND EXAMINATION**

PLATE NUMBER	CLEAR OPENING	OVERALL BASE	HEIGHT FRAME	APPROX WEIGHT
M-1240	110 10	15	12	

PAINTED: BITUMINOUS PAINT

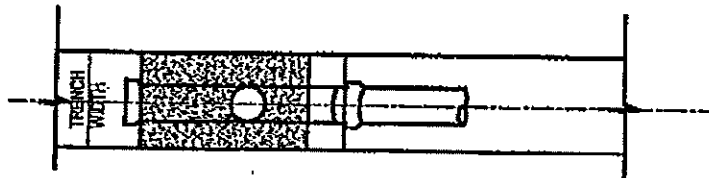
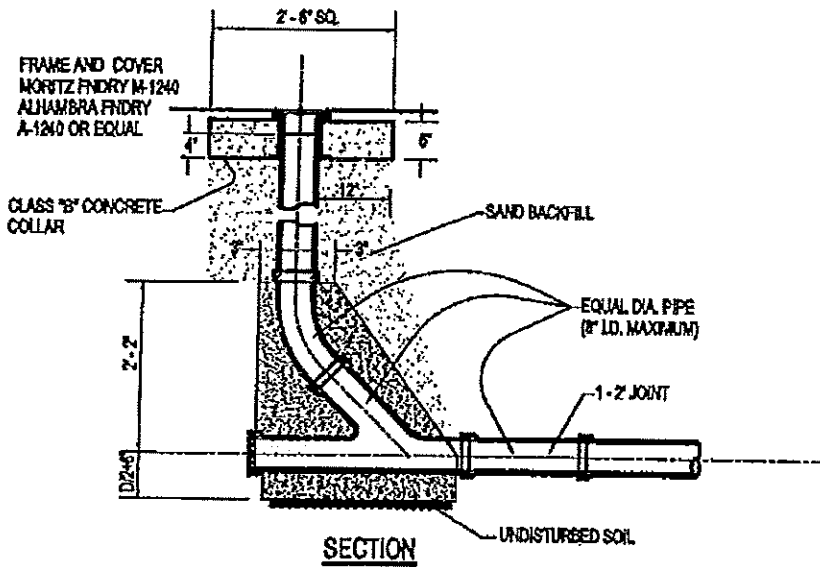
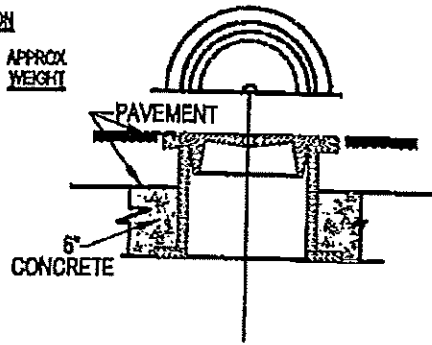

SECTION A-A

NOTES:

1. CLEAN OUTS IN PUBLIC RIGHT OF WAY APPROVED FOR USE IN UNINCORPORATED ONLY. PERMISSION TO CONSTRUCT CLEAN OUTS MUST BE OBTAINED FROM THE ENGINEER IN EACH CASE.

NO.	APPROVED	DATE

MDWAY CITY SANITARY DISTRICT
WESTMINSTER, CA

Handwritten signature and date: 11/2/2010

**CLEAN OUT
DETAIL
IN ROADWAY**

NO SCALE
STANDARD DWG.
S-073

GREASE INTERCEPTOR TANK WITH SAMPLE BOX

REQUIREMENTS:

1. Size and Location of Interceptor to be approved prior to installation.
2. Interceptor to have:
 - a. Sample Box
 - b. Sanitary Tee, inside sample box, discharge side
 - c. Vent
 - d. Cleanout prior to lateral connection
 - e. Manhole of each internal baffle tube -- no more than 10' between manholes
3. Inspection of Interceptor
 - a. All connections to Interceptor to be inspected prior to backfill.
 - b. Interceptor to be filled with water prior to inspection, per manufacturers instruction.
 - c. If required.
4. All manholes and sample boxes to be installed a minimum of 1/2" above finish grade/government with a concrete collar a minimum of 18" around all manhole lids and 12" deep.
5. Concrete Collar, Sample Box railing and all exterior piping supplied by installer.

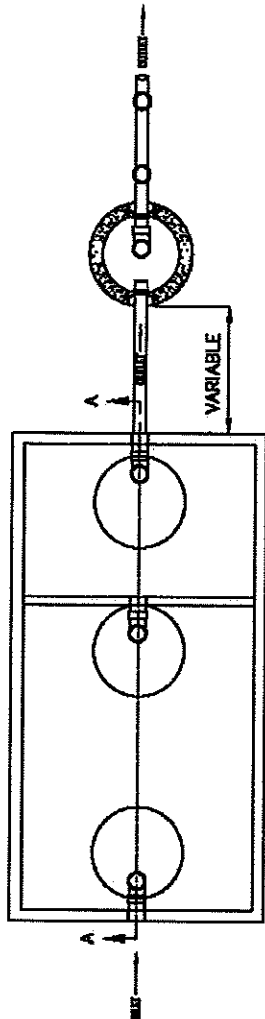

SAMPLE BOX

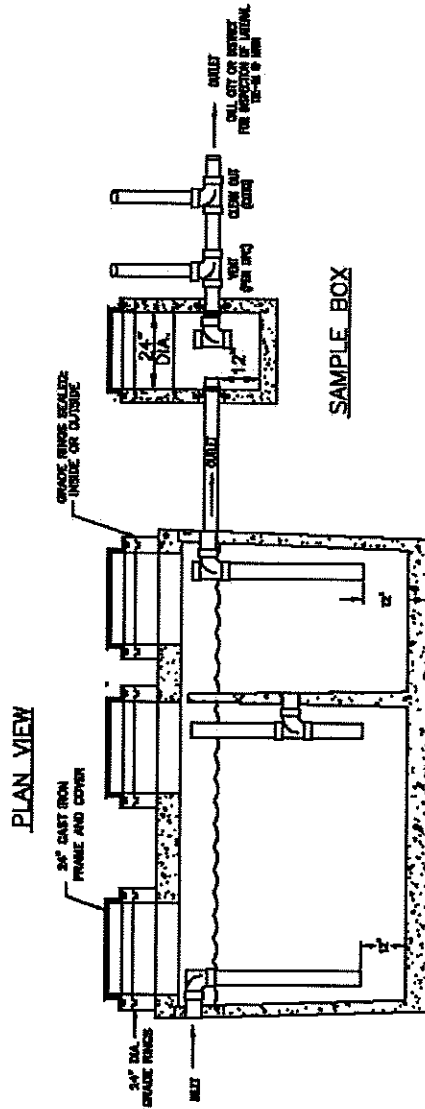

SIDE VIEW

MIDWAY CITY SANITARY DISTRICT
WESTMINSTER, CALIFORNIA

Handwritten signature and date: 11/2/2010

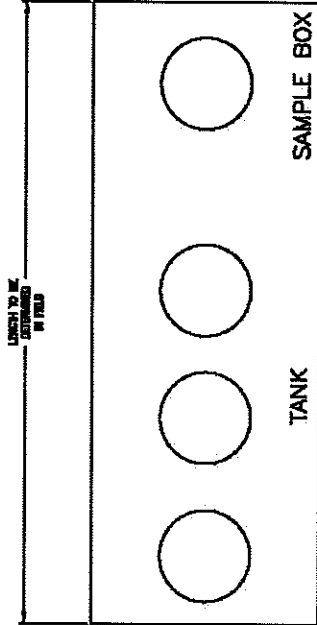

CONCRETE COLLAR DETAIL

PLAN VIEW



PLAN VIEW



END VIEW

GREASE INTERCEPTOR

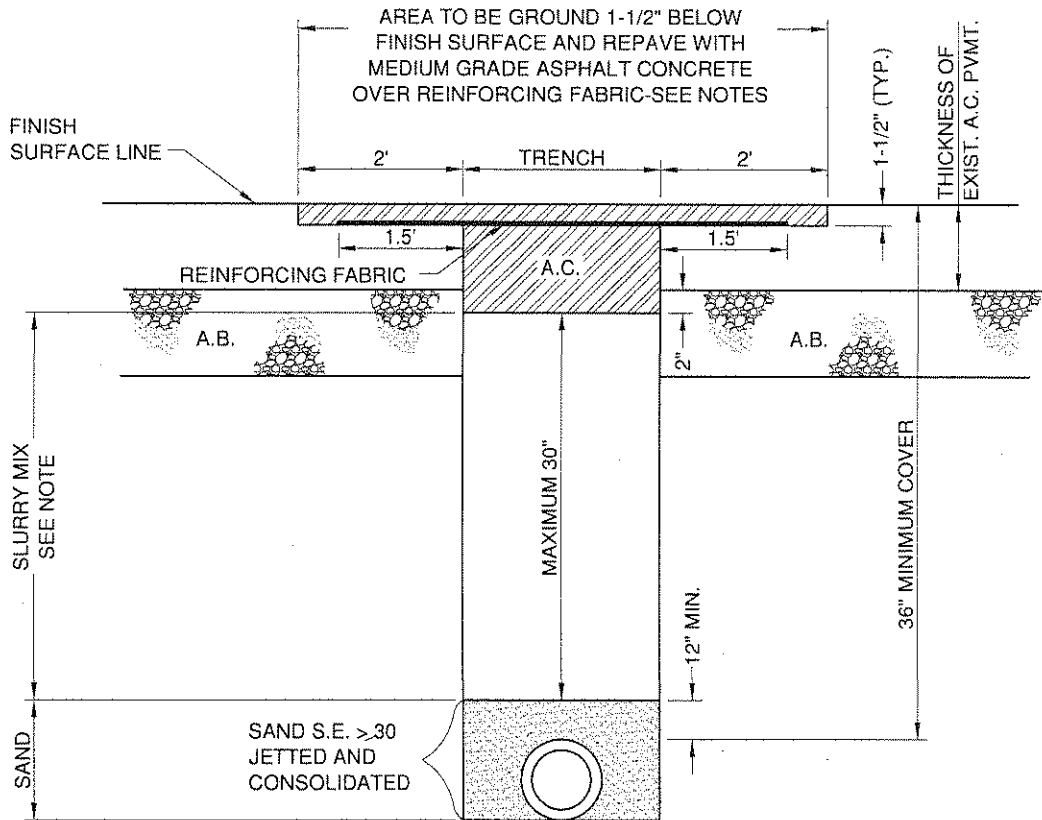

APPROVED:

Manu Jousse
 P.W. DIRECTOR / CITY ENGINEER



City of Westminster
 DEPARTMENT OF PUBLIC WORKS

REVISED DATE: 5/15/08

UTILITY EXCAVATION

STANDARD NUMBER

609

STANDARD DRAWING # 609

UTILITY EXCAVATION IN THE PUBLIC RIGHT OF WAY

The intent of these standards is to assure the best repair possible and reduce adverse impacts for the Public from road roughness, closures, and time to do work. IT MUST BE DONE SAFELY!

Notes

1. **Slurry Backfill:** Use 1.5 sack slurry with two (2) percent calcium chloride. If steel pipe is used then use non-chloride accelerator. Slurry shall be a maximum of thirty (30) inches deep, and shall be placed to the depth of two (2) inches below existing A.C. pavement.

2. **Pavement:** The trench shall be paved for the thickness of the existing paving plus a depth of two (2) inches, twenty-four (24) hours after slurry has been placed. The A.C. pavement shall be placed directly over the slurry with no aggregate base. The A.C. pavement in the trench plus two (2) feet each side of the trench, shall be ground a depth of one and one-half (1.5) inches below finish surface, and paved with a medium grade A.C. over reinforcing fabric.

Latex rubber asphalt concrete or other type of asphalt concrete material may be required based on existing conditions.

3. **Reinforcing Fabric:** The trench, plus one and one-half (1.5) feet on each side, shall be covered with reinforcing fabric prior to paving.

4. **Cold Mix:** Use of cold mix (UPM) to temporarily repair excavations the same day, in order to allow traffic flow on smooth transitions, is generally allowable. If cold mix is to be used, use (UPM) or approved equal, following the City Engineer's approval. It shall be a minimum thickness of three (3) inches for residential streets and six (6) inches for arterial and secondary arterials, and kept in good and safe condition.

5. **Slurry Seal:** Longitudinal continuous excavation shall be sealed using Type II slurry seal and cracks sealed, for the width of any affected lanes following the A.C. repairs, to the satisfaction of the City Engineer.

6. **Sand:** Sand shall be used for bedding and as cover for installed pipes. A minimum cover of twelve (12) inches of sand shall be used. On water service laterals, maintain twelve (12) inches of sand above the lateral, even when the elevation varies as the lateral is closer to the edge of gutter. Sand shall have a sand equivalence of greater than or equal to thirty (30). Sand shall be placed in maximum one foot lifts or less thickness as necessary to be able to achieve the necessary consolidation. It shall be jetted and consolidated to the satisfaction of the City Engineer.

7. **NPDES Requirements:** Streets shall be kept clean at all times. The City may require mechanical sweeping. The contractor shall maintain a clean work area, and prevent any material prohibited by the NPDES permit and the City's Water Quality Ordinance from entering the storm drain system.

The contractor shall meet all NPDES requirements during construction. All erosion control measures shall be taken during construction, to the satisfaction of the City Engineer. If no proper erosion control measures are taken on site, City may require that all operations cease and the encroachment permit may be revoked until proper measures have been taken to the satisfaction of the City Engineer.

8. **Traffic Control Plan:** Contractor (or applicant) shall submit traffic control plans complying with the California Manual on Uniform Traffic Control Devices (MUTCD), in advance for review and approval prior to excavating within the Public Right of Way, unless the excavation is an emergency, and then comply with the WATCH Manual.

STANDARD DRAWING # 609
UTILITY EXCAVATION IN THE PUBLIC RIGHT OF WAY
Notes (Continued)

9. **CAL-OSHA:** Contractor shall follow and will be responsible to obtain a Cal-OSHA permit when required.
10. **Steel Plates:** When steel plates are used, they shall be used per Caltrans Standards, with the following modification: Method Two (2) shall be applied to all arterial and secondary arterials. Steel plates shall be doweled into the ground, and/or welded together to eliminate movement. The City Engineer may recommend additional safety measures if it is deemed necessary. Steel plates shall always have cold mix around all edges. Recessing of steel plates shall be performed as required by the City Engineer on arterial and secondary arterial streets for planned activities requiring more than twenty-four (24) hours for open travel ways.
 - a) **Planned activity:** Planned activities shall be cleared through the Engineering Division to be working in the Public Right of Way under an approved schedule. Steel plates can remain at one location for twenty-four (24) hours, then shall be removed. If unforeseen conditions arise, then follow emergency procedures below.
 - b) **Emergency procedures:** When an unforeseen condition arises, steel plates can be maintained at a location for up to seventy-two (72) hours.
11. **Potholing/Temporary Excavating:** If potholing is the result of an investigation for a planned activity or for temporary excavations, cold mix (UPM) or approved equal could be used temporarily with suitable backfill, flush with adjacent existing asphalt. Following completion of the activity, standard excavation for permanent repair shall be followed. This will be done the same day as the excavation to reduce adverse impacts to roadway use. The City Engineer may require, based on the existing street condition, that excavation repair includes grinding along the edges, as per standard utilities excavation repair.
12. **Boring:** Boring shall be considered as a continuous trench as far as excavation repair. Potholes located intermittently will not be treated as separate excavations but as a continuous excavation. The City shall reserve the right to require boring or open trench as the situation may arise, to the satisfaction of the City Engineer.
13. **Moratorium on Newly Resurfaced Streets:** Excavation shall generally not be permitted in any street that has been resurfaced in the past five years. No permit will be granted to excavate in the Public Right of Way except for lateral extensions to customers/repairs less than one thousand five hundred (1,500) feet, or as approved by the City Council. Approved excavations in new streets shall require full lane or full width of the street, as determined by the City Engineer, with grind and overlay repairs. In case of an emergency, applicant shall obtain the City Engineer's approval for appropriate repair measures as soon as possible.
14. **Contractor Identification:** Anyone working within the Public Right of Way shall be identified with the entity's name, to be visible from both directions of travel lanes.
15. **Variances:** The City Engineer may consider variances as requested in advance, that meet the intent of these specifications.
16. **Lane Closure:** Multiple lane closures will normally be prohibited.
17. **Work Hours:** Arterial and secondary arterial streets work hours shall be restricted to 9:00 a.m. until 3:00 p.m. No traffic control shall be placed before 9:00 am and shall be removed by 3:00 p.m. Residential and secondary streets work hours shall be restricted to 7:00 a.m. until 4:00 p.m.

STANDARD DRAWING # 609
UTILITY EXCAVATION IN THE PUBLIC RIGHT OF WAY
Notes (Continued)

18. **Insurance:** Anyone working within the Public Right of Way shall comply with the City's insurance requirements, prior to obtaining an encroachment permit.
19. **Encroachment Permit:** Anyone excavating within the Public Right of Way shall be required to obtain an encroachment permit prior to start of any excavation.
20. **Underground Service Alert:** Section 4216/4217 of the Government Code requires a DigAlert Identification Number be issued before an "Encroachment Permit" will be valid. For your DigAlert I.D. Number, Call Underground Service Alert, Toll Free: 1-800-422-4133, two working days before you dig.

CALTRANS STANDARD
TEMPORARY STEEL PLATE BRIDGING WITH A NON-SKID SURFACE

Highway encroachment work involving excavations shall be identified during the review process of the permit applications package. It is recognized that to accommodate excavation work, steel plate bridging may be necessary. All permit conditions for use of steel plate bridging should be set forth in the special provisions of the permit.

Consideration of steel plate bridging in the review process should take into account the following factors:

1. Traffic volume and composition
2. Duration and size of the proposed excavation
3. Weather conditions

When it is determined in the review process that shoring will be a part of the permitted operation, the shoring shall conform to Caltrans standards.

When backfilling operations of an excavation in the traveled way, whether transverse or longitudinal, cannot be properly completed within a work day, steel plate bridging with a non-skid surface and shoring may be required to preserve unobstructed traffic flow. In such cases, the following conditions shall apply:

1. Steel plate bridging on freeways is not allowed.
2. Steel plates used for bridging must extend a minimum of twelve (12) inches beyond the edges of the trench.
3. Steel plate bridging shall be installed to operate with minimum noise.
4. The trench shall be adequately shored, per Caltrans Standards, to support the bridging and traffic loads.
5. Temporary paving with cold asphalt concrete shall be used to feather the edges of the plates, if plate installation by Method Two (2) is used.
6. Bridging shall be secured against displacement by using adjustable cleats, shims or other devices.

As required by Caltrans, steel plate bridging and shoring shall be installed using either Method One (1) or Two (2):

Method One (1) For speeds more than 45 mph:

The pavement shall be cold planed to a depth equal to the thickness of the plate and to a width and length equal to the dimensions of the plate.

Method Two (2) For speeds 45 mph or less:

Approach plate(s) and ending plate (if longitudinal placement) shall be attached to the roadway by a minimum of two (2) dowels pre-drilled into the corners of the plate and drilled two (2) inches into the pavement. Subsequent plates are butted to each other. Fine graded asphalt concrete shall be compacted to form ramps, maximum slope eighty-five (85) percent with a minimum twelve (12) inches taper to cover all edges of the steel plates. When steel plates are removed, the dowel holes in the pavement shall be backfilled with either graded fine or asphalt concrete mix, concrete slurry, or equivalent slurry satisfactory to the Caltrans' representative.

The contractor shall be responsible for maintenance of the steel plates, shoring and asphalt concrete ramps.

Unless specifically noted in the provisions of the permit, steel plate bridging should not exceed four (4) consecutive working days in any given week. Backfilling of excavations shall be covered with a minimum three (3) inches temporary layer of cold asphalt concrete.

The following table shows the required minimal thickness of steel plate bridging required for a given trench width:

TRENCH WIDTH	MINIMUM PLATE THICKNESS
0.3 m (1.0')	13 mm (1/2")
0.45 m (1.5')	19 mm (3/4")
0.6 m (2.0')	22 mm (7/8")
0.9 m (3.0')	25 mm (1")
1.2 m (4.0')	32 mm (1 1/4")

NOTE: For spans greater than four (4) feet, a structural design shall be prepared by a registered Civil Engineer and approved by Caltrans.

Steel plate bridging shall be steel plates designed for HS20.44 truck loading per Caltrans Bridge Design Specifications Manual. The permittee shall maintain on the steel plate a non-skid surface having a minimum coefficients of friction equivalent to 035 as determined by California Test Method 342 (see Caltrans Standards). If a different test method is used, the permittee may utilize standard test plates with known coefficients of friction available from each Caltrans District Materials Engineer to correlate skid resistance result to California Test Method 342.

A Rough Road Sign (W33) with black lettering on an orange background, may be used in advance of steel plate bridging. This is to be used with any other required construction signing.

EXHIBIT C
GENERAL CONDITIONS

GENERAL CONDITIONS

TABLE OF CONTENTS

GENERAL CONDITIONS

1. DEFINITIONS	1
2. EXECUTION OF CONTRACT	6
2.1. NOTICE TO PROCEED	6
2.2. CONTRACT BONDS	6
2.3. INSURANCE	7
2.4. CONTRACTOR’S LIABILITY NOT LIMITED BY INSURANCE	7
3. CONTROL OF THE WORK	7
3.1. AUTHORITY OF THE ENGINEER	7
3.2. SUPERVISION BY CONTRACTOR	8
3.3. CONTRACTING AND ASSIGNMENT	9
4. LEGAL RELATIONS AND RESPONSIBILITIES	9
4.1. LAWS TO BE OBSERVED	9
4.2. GENERAL INDEMNIFICATION	13
4.3. JOINT AND SEVERAL LIABILITY	15
4.4. RESPONSIBILITY FOR LOSS, DAMAGE OR INJURY	15
4.5. OWNERSHIP OF PLANS, SPECIFICATIONS, SHOP DRAWINGS	15
4.6. PRESERVATION OF PROPERTY	16
4.7. PERSONAL LIABILITY	17
4.8. WARRANTY OF TITLE	17
4.9. PROPERTY RIGHTS IN MATERIAL	18
4.10. TERMINATION FOR DEFAULT	18
4.11. TERMINATION FOR CONVENIENCE	20
4.12. NOTICE AND SERVICE THEREOF	22
4.13. PARTIAL INVALIDITY	22
4.14. WAIVER OF RIGHTS	23
4.15. TAXES	23
4.16. ASSIGNMENT OF ANTITRUST ACTIONS	23
4.17. SUBCONTRACTING	23
4.18. FLOW-DOWN REQUIREMENTS	23

4.19.	ASSIGNMENT.....	24
4.20.	WARRANTY (CONTRACTOR’S GUARANTEE).....	25
4.21.	SAFETY PRECAUTIONS AND EMERGENCIES.....	26
5.	SCOPE OF WORK.....	28
5.1.	GENERAL.....	28
5.2.	CONSTRUCTION PROCEDURES AND PROTECTION.....	28
5.3.	ERRORS AND OMISSIONS	31
5.4.	REQUEST FOR CHANGE (CHANGES AT CONTRACTOR’S REQUEST).....	32
5.4.	OWNER INITIATED CHANGES.....	35
5.5.	CLAIMS.....	37
5.6.	DISPUTES.....	38
6.	PROSECUTION AND PROGRESS OF THE WORK.....	39
6.1.	PROGRESS OF THE WORK.....	39
6.2.	TEMPORARY SUSPENSION OF WORK.....	39
6.3.	EXTENSION OF TIME FOR DELAY	39
6.4.	LABOR COMPETENCY	41
6.5.	USE PRIOR TO FINAL COMPLETION (BENEFICIAL OCCUPANCY).....	41
6.6.	SUBSTANTIAL COMPLETION.....	42
6.7.	FINAL COMPLETION AND FINAL ACCEPTANCE	43
6.8.	TIME OF COMPLETION.....	44
7.	PAYMENT FOR WORK.....	45
7.1.	PAYMENT - GENERAL	45
7.2.	PAYMENT – APPLICATIONS FOR PAYMENT	46
7.3.	CONTRACT PRICE ADJUSTMENTS AND PAYMENTS ...	47
7.4.	INCREASE OR DECREASE IN UNIT QUANTITIES	53
7.5.	SUSPENSION OF PAYMENTS	54
7.6.	MCSD’S RIGHT TO WITHHOLD CERTAIN AMOUNTS AND MAKE APPLICATION THEREOF.....	54
7.7.	STOP PAYMENT NOTICES.....	55
7.8.	AUDIT ACCESS TO RECORDS	55
7.9.	RETAINED FUNDS; SUBSTITUTION OF SECURITIES....	57

7.10. FINAL PAYMENT.....	57
8. MISCELLANEOUS	58
8.1. GOVERNING LAW.....	58

GENERAL CONDITIONS

1. DEFINITIONS

The following definitions are used in the Specifications or other Contract Documents. Their intent and meaning shall be as follows:

As-Built Drawings – A copy of the Plans used by the CONTRACTOR to record changes to the Work as specified in the General Requirements.

Beneficial Occupancy – Intended use of a building, system, structure, or facility by MCSD prior to Final Completion.

Bid – A form, or forms, completed in their entirety stating the Bidder's offer to both furnish all materials and to perform all Work required under the Contract. Bid also includes a proposal submitted by CONTRACTOR to perform all required Work.

Board – Board of Directors of the Midway City Sanitary District (MCSD). Where authority has been properly delegated to him, the Board may act through the General Manager

Bond – Performance Bond Public Works (Performance Bond), or Payment Bond Public Works (Payment Bond) or other instrument of security.

Business Day – A day on which MCSD offices are open for regular business, Monday through Friday between the hours of 8:00 A.M. to 4:30 P.M. (Pacific Time Zone) unless otherwise specified, and excluding MCSD Holidays.

Change Order – A written order by the ENGINEER, made bilaterally by MCSD and CONTRACTOR or unilaterally by MCSD, which covers alterations, changes, additions, or deletions to the Contract Documents or the Work in any manner which are necessary for the proper completion of the Work and which may result in adjustments to the Contract Price, period of performance, or both.

Claim – A written statement by the CONTRACTOR requesting additional time and/or money from MCSD arising out of acts or omissions of MCSD and/or differing conditions during the performance of the Contract which the CONTRACTOR could not have reasonably anticipated at the time of entering into the Contract, and which is submitted in response to MCSD's rejection of, or failure to approve, CONTRACTOR's Request for Change, or otherwise issue a Change Order modifying the Contract, adjusting the Contract Price and/or period of performance in a manner consistent with that which the CONTRACTOR believes is appropriate. The Claim shall be submitted in the manner and in the time consistent with the requirements set forth in these General Conditions.

Code – Codes of the State of California as well as any other federal or local law, statute, ordinance, rule or regulation.

Construction Schedule – The CONTRACTOR’s accepted Baseline Construction Schedule as it evolves through periodic updates that record actual progress of the Work to completion, when it shall show the “as-built” record of the CONTRACTOR’s work plan as executed.

CONSULTANT – Any CONSULTANT retained by MCSD or its (sub) consultant(s) who provides design or construction phase services for support of this Project.

Contract / Contract Documents – The following documents constitute a part of and comprise the Contract Documents: Agreement, CONTRACTOR’s Bid, Performance Bond Public Works, Payment Bond Public Works, insurance certificates and endorsements, Plans and Specifications, General Conditions, plan clarifications, and Supplemental Agreements, including Change Orders issued after Contract award.

Contract Duration / Time of Completion – The period of performance provided for in the Agreement, and as amended via Change Orders.

Contract Milestone / Milestone – A significant performance point in the Work, as provided for in the Contract Documents.

CONTRACTOR – The individual, partnership, joint venture, corporation, or other combination thereof, identified as such in the Contract, and referred to throughout the Contract Documents as if singular in number and who directly contracts with MCSD. The term “CONTRACTOR” means the CONTRACTOR or its authorized representative.

Contract Price – The total amount of money for which the Contract is awarded, as modified by any Change Orders.

Contract Unit Price – The amount stated in the CONTRACTOR’s Bid for a single unit of an element of the Work.

Critical Path – A continuous sequence of schedule network activities with the least amount of total float, ending at a Contract Milestone.

Days – Unless otherwise specifically stated, the term “days” will be understood to mean consecutive calendar days.

Drawings – See Plans.

DISTRICT – Midway City Sanitary District.

DISTRICT Holidays – MCSD recognizes the following holidays on which its offices are closed for regular business: New Year’s Day, Washington’s Birthday, Memorial Day, Independence Day, Labor Day, Veteran’s Day, Thanksgiving Day, the day after Thanksgiving, Christmas Eve, and Christmas Day. Holidays that occur on Saturdays and Sundays will be observed on the preceding Fridays and the following Mondays, respectively. MCSD reserves the right to recognize additional holidays without prior notice.

ENGINEER –The District Engineer of MCSD or MCSD’s designee.

Extra Work – New or unforeseen Work, or added Work of a different character or function and for which no basis for payment is prescribed in the Contract Documents; or that involves revisions of the details of the Work in such manner as to render inequitable payment under items upon which the CONTRACTOR bid in its Bid; or that Work to be done under “stipulated prices” as given in the Schedule of Prices.

Final Acceptance – Action taken by MCSD Board of Directors accepting the Work as fully completed.

Final Completion / Contract Completion / Completion / Completion Date – The Contract Milestone recognized through action taken by the ENGINEER certifying that the Work is fully completed under the Contract Documents prior to MCSD’s acceptance of the Work as fully completed.

Float – The flexibility that an activity has against the critical path.

Fragment– A fragment of the schedule network that typically illustrates a particular sequence of activities for thorough analysis.

General Conditions – Legal and contractual instructions to the CONTRACTOR setting forth both the CONTRACTOR and MCSD responsibilities for business related activities pertaining to the Contract. The term “General Conditions” used in the Specifications shall be interpreted to refer to the General Conditions of the Contract Documents.

General Manager – The individual designated by MCSD as its Chief Executive Officer and agent.

General Requirements – Legal and contractual instructions to the CONTRACTOR setting forth both the CONTRACTOR and MCSD responsibilities for technical aspects of the Work indicated under the Contract. The term “General Requirements” used in the Specifications shall be interpreted to refer to the General Requirements of the Contract Documents.

INSPECTOR – The individual(s) designated by the ENGINEER as the field Project representative with delegated authority to enforce the requirements of the Contract Documents, subject to the approval of the General Manager.

Law – Any federal, state or local law, statute, ordinance, rule, regulation or code.

Legal Address of CONTRACTOR – The address given on the CONTRACTOR’s Bid shall be the legal address of the CONTRACTOR and is the designated place to which all notices, letters or other communications to the CONTRACTOR shall be mailed or delivered.

MCSD – Midway City Sanitary District.

Notice to Proceed -- A written notice given by MCSD to the CONTRACTOR fixing the date on which the time for performance under the Contract will commence.

MCSD – Midway City Sanitary District.

Operational Acceptance – Written notification by the ENGINEER accepting the Work as operationally complete. Used for the purpose of placing equipment or facilities in service before all of the Contract Work is completed.

or equal / Or Equal / OR EQUAL – Any product, equipment, material, thing, or service which is proposed by the CONTRACTOR for use in the Work, which is equal to or better than, and is as suitable as the product, material, equipment, thing or service specified in the Contract Documents as to function, performance, reliability, quality, and general configuration.

OWNER – Midway City Sanitary District.

Payment Bond Public Works – A bond required from a CONTRACTOR to secure payment to Subcontractors, laborers, mechanics and Suppliers employed on the Work of the Contract.

Performance Bond Public Works – A bond required from a CONTRACTOR at the time of execution of a Contract which guarantees faithful performance of the Contract by the CONTRACTOR.

Plans – The part of the Contract Documents consisting of the plans, profiles, typical and general cross-sections, working drawings, or exact reproductions thereof, which show the location, character, dimensions and details of the Work to be done (if any).

Project(s) – The entire scope of Work covered by all Contract Documents.

Proposal – A standard form supplied by MCSD as tear-out sheets, which when completed in its entirety and executed, shall constitute a Bid Submittal.

Record Drawings – Construction drawings from completed projects maintained by MCSD as a record of how facilities were actually constructed. These are generally created from the original plans, addendum and Change Order drawings, and the CONTRACTOR's as-built copy of the construction plans.

Request for Change – A written request by the CONTRACTOR to MCSD for the issuance of a Change Order.

Schedule of Prices - A list of Bid Item(s) in the Bid or Proposal including the item number, approximate quantities, item descriptions, total price per item and total amount of Bid.

Specifications – Elements of the Contract Documents and revisions which describe the commercial, legal, technical and non-technical requirements of the Project. Specifications

include but are not limited to Project Requirements, Provisions, General Conditions, General Requirements, Supplementary Conditions, Technical Specifications, and all revisions made to the Specifications including Addenda, Notice to Bidders, and Change Orders, signed by the ENGINEER and authorized by the Board.

Standard Plans / Standard Drawings – Details of standard structures, devices or instructions referred to on the Plans or in the Specifications by title or number and issued by MCSD.

Standard Specifications for Public Works Construction – The latest edition of Standard Specifications for Public Works Construction (“Green Book”) as written and promulgated by the Public Works Standards, Inc.

Subcontractor – One who is licensed pursuant to California Business and Professions Code, Section 7000 et. seq., and who contracts directly with the prime CONTRACTOR or with another Subcontractor to perform some part of the Work. A Subcontractor does not have any direct contract with MCSD related to the Work.

Supplemental Agreements – Written agreements between MCSD and the CONTRACTOR, covering schedules, drawings, instructions, alterations, amendments or extensions to the Contract and including Contract Change Orders.

Supplier – An individual, organization, or firm who is not required for the purposes of the Work to be licensed pursuant to California Business and Professions Code as a CONTRACTOR or Subcontractor, within the meanings of those terms as defined hereinabove, who provides equipment and/or materials for the Work to the CONTRACTOR or a Subcontractor, including that fabricated to a special design, but who does not perform labor at the site except for labor or labor supervision required by some manufacturers as part of their equipment installation for warranty or other purposes or for operation of rented equipment, and only to the extent such labor or labor supervision is excepted from licensing requirements under the California Business and Professions Code, including but not limited to Section 7040 et seq. The term “supplier” also includes fabricator, manufacturer, or vendor.

Surety or Sureties – The bondsmen or party or parties who guarantee the fulfillment of the Contract, or a portion of the Contract, by Bond and whose signatures are affixed to the Bond.

Terms – The terms “Approved”, “Directed”, “Satisfactory”, “Accepted”, “Acceptable”, “Proper”, “Required”, “Necessary”, and “Or Equal” mean as approved, directed, satisfactory, accepted, acceptable, proper, required, necessary, and or equal, in the opinion of the ENGINEER.

Total Float – The amount of time that the actual start and finish of an activity can be delayed along a given network path without delaying the Contract Completion date.

Trade Names – Where a certain product is called by its Trade Name, it is intended as a guide for type and quality.

Typical Details – Details of standard structures, devices or instructions referred to on the Plans and Specifications by title or number and developed by the CONSULTANT.

Unavoidable Delay – An interruption of the Work beyond the control of the CONTRACTOR and which interruption the CONTRACTOR could not have avoided by the exercise of care, prudence, foresight, diligence and mitigation.

Work – All the Work specified in the Contract Documents necessary to complete the requirements of the Contract, including the furnishing of all labor and materials. Also, the completed construction or parts thereof required to be provided under the Contract Documents, including all materials, equipment, and supplies incorporated or to be incorporated in the construction.

2. EXECUTION OF CONTRACT

2.1. NOTICE TO PROCEED

Upon receipt of all properly executed Contract Documents from CONTRACTOR, MCSD shall execute all documents as necessary, establish the effective date of the Contract, and MCSD shall issue a Notice to Proceed, unless the ENGINEER determines that good cause exists to delay the issuance. In such case, MCSD may delay issuance of the Notice to Proceed. Said Notice to Proceed shall be forwarded to the CONTRACTOR by mail or by any other means which shall provide confirmation of a date and time receipt acknowledgment, including but not limited to electronic telecommunication. The time required for completion of the Contract shall begin upon the effective date of the Notice to Proceed.

2.2. CONTRACT BONDS

Before or concurrently with final execution of the Contract, the CONTRACTOR shall furnish two Surety Bonds, on the forms provided by MCSD, as part of the Contract Documents. Each Bond shall have good and sufficient Sureties subject to the approval of MCSD. The first shall ensure the payment of all labor performed and material used in the Work, and the second shall ensure the faithful performance of the Contract.

The Payment Bond Public Works (Labor and Material Bond) shall be in an amount equal to one hundred percent (100%) of the Bid price, so conditioned as to inure to the benefit of persons furnishing materials to the CONTRACTOR for and/or performing labor upon the Work of the CONTRACTOR. This Bond shall be maintained by the CONTRACTOR in full force and effect until the Work has been completed and accepted by MCSD and all claims for labor and material have been paid. As changes to the Contract occur via approved Change Orders, the CONTRACTOR shall assure that the amount of the Bond is adjusted to maintain 100% of the Contract Price.

The Bond for faithful performance (Performance Bond Public Works) shall be an amount equal to one hundred percent (100%) of the Total Amount of Bid price, so conditioned as to insure

the faithful performance by the CONTRACTOR of all Work within the time limit prescribed, and in a manner that is satisfactory and acceptable to MCSD. This Bond shall be maintained by the CONTRACTOR in full force and effect during the performance of the Work of the Contract and until the Work has been accepted by MCSD. This Bond shall also apply to the use of patented articles, materials or processes; to guarantee the payment of all stop payment notice claimants, and shall assure faithful performance of the one (1) year warranty from the date of Final Acceptance by MCSD and any extensions to said warranty period as provided by the Contract Documents. As changes to the Contract occur via approved Change Orders, the CONTRACTOR shall assure that the amount of the Bond is adjusted to maintain the 100% of the Contract Price.

Should any Surety or Sureties ever be deemed unsatisfactory by MCSD, the CONTRACTOR shall be notified to that effect, and the CONTRACTOR shall forthwith substitute a new Surety or Sureties satisfactory to MCSD. No further payment shall be deemed due or will be made under the Contract until the new Sureties shall qualify and be accepted by the Board of Directors. For Surety companies to be acceptable to MCSD they must be admitted to do business as a Surety in and have an agent for service of process in California.

2.3. INSURANCE

The CONTRACTOR shall purchase and maintain insurance, in amounts equal to the requirements in the form and manner provided for in the Contract Documents.

2.4. CONTRACTOR'S LIABILITY NOT LIMITED BY INSURANCE

Nothing contained in the insurance requirements is to be construed as limiting the liability of the CONTRACTOR or the CONTRACTOR's Sureties.

3. CONTROL OF THE WORK

3.1. AUTHORITY OF THE ENGINEER

The ENGINEER serves as the agent of MCSD and will observe the accomplishment of the Work in accordance with the provisions of the Contract. The ENGINEER will decide any and all questions which may arise as to the interpretations of the Contract Documents, as to the quality and acceptability of materials furnished and Work performed, as to the manner of performance, and as to the rate of progress of the Work. All questions as to the acceptable performance of the Contract on the part of the CONTRACTOR shall be decided by the ENGINEER.

It shall be the duty of the CONTRACTOR to call the ENGINEER's attention to apparent errors and omissions in the Plans and Specifications. The ENGINEER may, by appropriate written instructions, correct errors and omissions, which instructions shall be as binding upon the CONTRACTOR as though contained in the original Contract Documents. The ENGINEER

shall have authority to make minor changes in the Work not involving extra or lesser cost, and not inconsistent with the intent of the Contract Documents.

All instructions, rulings, and decisions of the ENGINEER shall be in writing, and shall be final and binding on the CONTRACTOR unless formal written objection is made as specified herein.

It is expressly agreed that the ENGINEER shall not have the power to waive any of the obligations of the Contract Documents for the furnishing by the CONTRACTOR of good and suitable material, and for performing the Work as herein described. Failure or omission on the part of the ENGINEER to reject defective or inferior Work or materials, or the ENGINEER's release of the CONTRACTOR from obligations to remedy the defective or inferior Work, shall not imply acceptance of the Work. Upon discovery of said defective Work, the CONTRACTOR shall immediately tear out, remove, and properly replace the defective Work without additional compensation. Neither shall such failure or omission, nor any acceptance by the ENGINEER, or by the Board be construed as relieving the responsibilities of the CONTRACTOR or its Sureties, for a sum of money as may be needed to remove and replace, or to repair, any or all Work or materials which is found to be defective or inferior. In such instance, in lieu of the recovery of said sum of money, MCSD may permit the CONTRACTOR to perform, at the CONTRACTOR's own expense, the work of removing and replacing or repairing Work or materials found to be defective or inferior.

The Board shall have the final authority in all matters affecting the Work. Within the scope of the Contract Documents, the ENGINEER shall have the authority to enforce compliance with the Contract Documents. The CONTRACTOR shall promptly comply with all instructions from the ENGINEER which are made in accordance with the Contract Documents.

In all matters relating to acceptability of construction materials and equipment, execution and progress of Work, percentage of completion, the interpretation of Contract Documents, delays and Claims by the CONTRACTOR, the decision of the ENGINEER shall be final and binding unless the CONTRACTOR timely follows the appropriate procedures to object to the same as set forth herein under Claims and Disputes, or unless otherwise ordered by the Board or General Manager.

3.2. SUPERVISION BY CONTRACTOR

The CONTRACTOR is required to give personal attention to the fulfillment of this Contract, and to keep the Work under control. The CONTRACTOR shall have a copy of the Contract Documents available at the worksite at all times. During the CONTRACTOR's absence from the worksite, the CONTRACTOR shall provide a site superintendent with full authority to receive and execute such instructions, orders or directions as the ENGINEER may issue in connection with the provisions of the Contract Documents. The site superintendent shall be available on site at all times during progress of the Work.

The CONTRACTOR shall supervise and direct the Work competently and efficiently, devoting such attention thereto and applying such skills and expertise as may be necessary to

perform the Work in accordance with the Contract Documents. The CONTRACTOR shall be solely responsible for the means, methods, techniques, sequences and procedures of construction, but the CONTRACTOR shall not be solely responsible for the negligence of others in the design or selection of a specific means, method, technique, sequence, or procedure of construction which is indicated in and required by the Contract Documents except as otherwise provided in the General Conditions, entitled Errors and Omissions.

The CONTRACTOR shall be responsible to see that the completed Work complies with the Contract Documents.

Before any Work is done at the worksite, the CONTRACTOR shall give written notice to the ENGINEER stating the name, home address and telephone number of the CONTRACTOR's site superintendent. The ENGINEER shall be informed in writing prior to any change of site superintendent. A statement naming more than one representative at a time to be in charge, depending upon which is present at the time, will not be acceptable.

The CONTRACTOR shall file with the ENGINEER the names, addresses, and telephone numbers of representatives who can be contacted at any time in case of emergency. These representatives must be fully authorized and equipped to correct unsafe or excessively inconvenient conditions on short notice.

If a site superintendent or the CONTRACTOR is not present at a particular location of the worksite, the ENGINEER may inform the foreman, or other person in charge, regarding an interpretation of the Contract Documents or of any disapproval or rejection of materials or Work performed. Information so given shall be as binding as if given to the superintendent.

3.3. CONTRACTING AND ASSIGNMENT

Subcontractors not specifically listed in the Bid Submittal or otherwise disclosed to MCSD will not be recognized as such and will not be allowed to work on the Project unless the value of said Work is less than one-half of one percent of the total Contract Price. All persons engaged in the Work of construction will be considered as employees of the CONTRACTOR, and not as independent contractors. No assignment of any portion of the Work or of any obligation or duty under the Contract is permitted without the express prior written consent of MCSD, and as otherwise authorized by the Contract Documents.

4. LEGAL RELATIONS AND RESPONSIBILITIES

4.1. LAWS TO BE OBSERVED

The CONTRACTOR shall, at its own cost and expense, observe and keep fully informed regarding all existing and future federal, state, city, county, local agency or special district laws and regulations which may in any manner affect those engaged or employed on the Project, or the materials to be used or furnished, or which may in any respect govern, control or otherwise affect the conduct of the Project or any part thereof. The CONTRACTOR shall, at its own cost and expense, furnish all materials and facilities required to comply with such laws and

regulations. The CONTRACTOR shall furnish copies of all valid licenses and certifications required of Suppliers, Subcontractors, or employees for the Work upon the request of the ENGINEER.

If any discrepancy or inconsistency is discovered on the Plans, Specifications, permits, or in the Contract Documents for the Project in relation to any such law, regulation, order or decree, the CONTRACTOR shall forthwith report the same to MCSD, in writing, and shall cease operations on that part of the Work until MCSD has given the CONTRACTOR appropriate instructions as provided for in General Conditions, Errors and Omissions.

The CONTRACTOR shall defend and indemnify MCSD, the Board of Directors, the ENGINEER, the CONSULTANT, and its subconsultants, each of their directors, officers, employees or agents against any claim or liability arising from or based on the violation of any such law, or regulation, whether by the CONTRACTOR or any of the CONTRACTOR's employees or agents, including its Subcontractors and Suppliers.

Attention is directed to the following specific regulations and requirements that are included in the Contract Documents. This list of regulations is not warranted to be complete and the burden of ascertaining legal requirements that must be satisfied shall rest solely with the CONTRACTOR.

- A. Employment of Apprentices. The CONTRACTOR and any Subcontractor shall comply with the requirements of Sections 1777.5 and 1777.6 of the California Labor Code in the employment of apprentices.

Information relative to apprenticeship standards, wage schedules and other requirements may be obtained from the Director of Labor Relations, c/o the Administrator of Apprenticeship, San Francisco, California, or from the Division of Apprenticeship Standards and its branch offices.

A CONTRACTOR or Subcontractor that is determined by the chief of the Division of Apprenticeship Standards to have knowingly violated Labor Code Section 1777.5 shall forfeit as a civil penalty an amount not to exceeding One Hundred Dollars (\$100) for each full calendar day of noncompliance. A contractor or subcontractor that knowingly commits a second or subsequent violation within a three-year period, if the noncompliance results in apprenticeship training not being provided as required by this chapter, shall forfeit as a civil penalty the sum of not more than three hundred dollars (\$300) for each full calendar day of noncompliance. (California Labor Code Section 1777.7)

- B. Travel and Subsistence Payments. Each worker needed to execute the Work must be paid travel and subsistence payments as defined in the applicable collective bargaining agreements filed in accordance with California Labor Code Section 1773.1.
- C. Hours of Labor. The CONTRACTOR shall forfeit, as a penalty to MCSD, twenty-five dollars (\$25) for each worker employed in the execution of the Contract by the CONTRACTOR or any Subcontractor, for each calendar day during which such worker is

required or permitted to work more than eight (8) hours in any one (1) calendar day and forty (40) hours in any one (1) calendar week in violation of the provisions of the Labor Code and, in particular, Section 1810 to Section 1815 thereof, inclusive, except that work performed by employees of CONTRACTOR in excess of eight (8) hours per day and forty (40) hours during any one (1) week shall be permitted upon compensation for all hours worked in excess of eight (8) hours per day at not less than 1-1/2 times the basic rate of pay as provided in said Section 1815.

- D. Nondiscrimination in Employment. The CONTRACTOR shall comply with Government Code §12940. Projects under this Contract will obligate the CONTRACTOR and Subcontractors not to discriminate in employment practices. CONTRACTOR must, if requested, submit a compliance report concerning its employment practices and policies. The CONTRACTOR must be prepared to comply in all respects with the requirements regarding nondiscrimination including but not limited to California Labor Code Section 1735.
- E. Prevailing Wage Rates. The CONTRACTOR shall comply with California Labor Code Section 1771 by the payment of prevailing wages as established by the Director of the State Department of Industrial Relations. In accordance with Labor Code Section 1775, the CONTRACTOR and any Subcontractor shall forfeit, as a penalty to MCSD, not more than Two Hundred Dollars (\$200) for each calendar day or portion thereof for each worker paid less than the established prevailing rates for such work or craft in which such worker is employed for any Work done under the Contract in violation of the provisions of the California Labor Code Sections 1770 to 1780, inclusive. In addition to said penalty and pursuant to said Section 1775, for each day or portion thereof in which each worker was paid less than the prevailing wage rate the difference between such established prevailing wage rates and the amount paid to each worker shall be paid to each worker by the CONTRACTOR. Per California Labor Code 1773.2, MCSD will have on file copies of the prevailing rate of per diem wages at its principal office and at each job site, which shall be made available to any interested party upon request.
- F. California Department of Industrial Relations (DIR) Registration and Record of Wages.
- 1) The CONTRACTOR and its subcontractors shall comply with the registration requirements of Labor Code §1725.5. Pursuant to Labor Code §1771.4, the Work is subject to compliance monitoring and enforcement by the DIR.
 - 2) The CONTRACTOR shall maintain accurate payroll records and shall comply with all of the provisions of Labor Code §1776, and shall submit payroll records to the Labor Commissioner pursuant to Labor Code §1771.4(a)(3). Penalties for non-compliance with the requirements of §1776 may be deducted from progress payments per §1776.
 - 3) Pursuant to Labor Code §1776, the CONTRACTOR shall furnish a copy of all certified payroll records to MCSD and/or the general public upon request, provided the public request is made through MCSD, the Division of Apprenticeship

Standards or the Division of Labor Enforcement of the Department of Industrial Relations.

- 4) The CONTRACTOR shall comply with the job site notices posting requirements established by the Labor Commissioner per Title 8, California Code of Regulations §16461(e) or other regulation promulgated pursuant to Labor Code Section 1771.4(a)(2).

G. Public Records Act.

1) Ownership and Disclosure

Except as otherwise provided herein, all records, documents, Drawings, Plans, Specifications, and all other information relating to the conduct of MCSD's business, including information submitted by the CONTRACTOR ("Records"), shall become the exclusive property of MCSD and shall be deemed public records. Said Records are subject to the provisions of the California Public Records Act (Government Code § 6250 et. seq.). MCSD's use and disclosure of its records are governed by this Act. MCSD will use its best efforts to inform the CONTRACTOR of any request for any financial records or documents marked "Trade Secret", "Confidential" or "Proprietary" provided by the CONTRACTOR to MCSD. MCSD will not advise as to the nature or content of documents entitled to protection from disclosure under the California Public Records Act.

2) Litigation Related to Disclosure

In the event of litigation concerning the disclosure of any Records, MCSD's sole involvement will be as a stakeholder, retaining the Records until otherwise ordered by a court. The submitting party, at its sole expense and risk, shall be fully responsible for any and all fees for prosecuting or defending any action concerning the Records and shall indemnify and hold MCSD harmless from all costs and expenses including attorney's fees in connection with any such action.

H. Subcontracting. Pursuant to the provisions of Sections 4100 to 4114, inclusive, of the California Public Contract Code, as amended from time to time, the CONTRACTOR shall not, without the consent of MCSD:

- 1) Substitute any person(s) or Subcontractor(s) designated in the original Bid.
- 2) Assign or transfer any subcontract or allow any subcontract to be performed by anyone other than the original Subcontractor.
- 3) Sublet or subcontract any portion of the Project not so designated in the original Bid when the value of said Work is greater than one-half of one percent (1/2%) of the CONTRACTOR's total Bid.

A violation by the CONTRACTOR of any of the provisions of Sections 4100 to 4114, inclusive, of the Public Contract Code, shall be deemed a violation of the Contract and MCSD will impose the penalties provided therein.

- I. Workers' Compensation. Pursuant to the requirements of California Labor Code Section 1860, the CONTRACTOR shall secure the payment of compensation to CONTRACTOR's employees in accordance with the provisions of Section 3700 of the California Labor Code.
- J. California Air Resources Board (CARB) In-Use Off-Road Diesel Fleets Regulation.
 - 1) The CONTRACTOR and its subcontractors shall comply with all applicable CARB regulations, including, without limitation, all applicable requirements of CARB's regulations governing In-Use Off-Road Diesel-Fueled Fleets, 13 CCR §§ 2449-2449.3.
 - 2) Pursuant to 13 CCR § 2449(i)(1), if applicable, prior to entering into the Contract, the CONTRACTOR shall provide MCSD with a valid Certificate of Reported Compliance from CARB for all vehicles to be used by CONTRACTOR and/or any of its subcontracts for Work under the Contract that are subject to CARB's In-Use Off-Road Diesel Fleets Regulations. If the Project qualifies as an "emergency operation" as defined in 13 CCR §2449(c)(18), pursuant to 13 CCR § 2449(i)(4), in lieu of providing Certificates of Reported Compliance as required above, CONTRACTOR may, instead provide MCSD with an attestation from itself and/or its subcontractors that the vehicles are operated on the Project for emergency operations only.
- K. State Regulations. All requirements applicable, as established by CalEPA, CalOSHA, CARB, DIR, or other state regulatory agencies.
- L. Federal Regulations. All requirements applicable, as established by the EPA, OSHA, or other federal regulatory agencies.

4.2. GENERAL INDEMNIFICATION

The CONTRACTOR shall, with respect to all Work covered by or incidental to these Contract Documents, be responsible for any liability imposed by law and shall indemnify, defend and hold MCSD, the ENGINEER, the CONSULTANT and its subconsultants, and each of their directors, officers, agents and employees, and all public entities issuing permits to the CONTRACTOR, free and harmless from and against all of the following:

Any claim, suit or action of every name, kind, and description, loss, damage, cost, expenses, including reasonable attorney's fees and expert fees, costs of compliance with administrative orders and directives, litigation, arbitration, awards, fines, and administratively or judicially-imposed penalties or judgments, arising by reason of death or bodily injury to person(s), injury to property, or other loss, damage or expense, resulting from the construction of the Work, design defects (if design originated by the CONTRACTOR only), defects in the Work, or by

or on account of acts, errors or omissions of the CONTRACTOR or CONTRACTOR's Subcontractors, Suppliers, employees, invitees, or agents or from any other cause whatsoever arising during the progress of the Work or at any time prior to its completion and Final Acceptance, including any of the same resulting from MCSD's alleged or actual acts, errors, or omissions regardless of whether on or off of the worksite. Said responsibility shall extend to claims, demands or liability for loss, damage or injuries occurring or discovered after completion of the Work, as well as during the progress of the Work. However, the CONTRACTOR shall not be obligated under this Contract to indemnify MCSD, the ENGINEER or its CONSULTANT(s) with respect to the active negligence, sole negligence, or willful misconduct of MCSD, the ENGINEER, or its CONSULTANT(s).

In addition, if any action is brought against the CONTRACTOR or any Subcontractor to enforce a stop payment notice or Notice to Withhold, which names MCSD as a party to said action, MCSD shall be entitled to reasonable attorney's fees, costs and necessary disbursements arising out of the defense of such action by MCSD. MCSD shall be entitled to deduct its costs for any stop payment notice filed, whether court action is involved or not.

In any and all claims against the indemnified parties by an employee of the CONTRACTOR, any Subcontractor, any Supplier, anyone directly or indirectly employed by any of them, or anyone for whose acts any of them may be liable, the indemnification obligation as specified herein shall not be limited in any way by the amount or type of damages, compensation, or benefits payable by or for the CONTRACTOR, or any Subcontractor, or any Supplier or other person under Workers' Compensation acts, disability benefit acts, or other employee acts.

The obligations of the CONTRACTOR as specified herein shall not extend to the liability of the ENGINEER, the CONSULTANT or its subconsultants, and each of their directors, officers, agents and employees, arising out of or resulting from or in connection with the preparation or approval of maps, Drawings, opinions, reports, surveys, designs or Specifications, provided that the foregoing was the sole and exclusive cause of the loss, damage or injury.

The CONTRACTOR shall also be responsible for and shall indemnify, defend and hold harmless MCSD, the ENGINEER, the CONSULTANT and its subconsultants, and each of their directors, officers, employees, and agents from and against all losses, expenses, damages (including damages to the Work itself), attorney's fees, and other costs, including all costs of defense, which any of them may incur with respect to the failure, neglect, or refusal of the CONTRACTOR to faithfully perform the Work and all of the CONTRACTOR's obligations under the Contract. Such costs, expenses, and damages shall include all costs, including attorney's fees incurred by the indemnified parties in any lawsuit to which they are a party.

In the event CONTRACTOR or its insurer refuses or fails to provide a legal defense to MCSD after receiving written notice of the legal action and a tender and demand for defense, MCSD shall have the right to select counsel of its own choice to represent all the interests of MCSD at CONTRACTOR's cost and expense. CONTRACTOR agrees that the amount of legal costs and expenses, including attorneys' fees, may be withheld by MCSD from any Contract amounts due and owing to CONTRACTOR until such time as a final determination is made as

to the responsibility for payment of said fees and costs. CONTRACTOR further agrees that to the extent MCSD incurs such damages and the damages exceed any remaining Contract amounts due and owing to CONTRACTOR, CONTRACTOR shall reimburse MCSD for all such additional damages upon demand by MCSD for the same.

CONTRACTOR and MCSD agree that nothing in this Section is intended to be or is a prevailing party clause as it pertains to attorney's fees.

4.3. JOINT AND SEVERAL LIABILITY

If the CONTRACTOR is a joint venture or partnership, each venturer or partner shall be jointly and severally liable for any and all of the duties and obligations of the CONTRACTOR that are assumed under or arise out of the Contract. Each of such venturers or partners waives notice of the breach or non-performance of any undertaking or obligation of the CONTRACTOR contained in, resulting from or assumed under the Contract, and the failure to give any such notice shall not affect or impair such venturer's or partner's joint and several liability hereunder.

4.4. RESPONSIBILITY FOR LOSS, DAMAGE OR INJURY

Neither MCSD, nor its Directors, officers, employees or agents shall be held responsible in any manner for any loss or damage that may happen to the Work or any part thereof during the course of construction; for any loss or damage to any of the materials, equipment, supplies or other things used or employed in performing the Work; for injury to or death of any person, either workers or the public; or for damage to property, from any cause that might have been prevented by the CONTRACTOR, CONTRACTOR's workers, or anyone employed by the CONTRACTOR.

In the event any hazardous materials, including but not limited to asbestos, are utilized in construction or hazardous materials are otherwise encountered during construction, the CONTRACTOR shall take all appropriate precautions to protect persons and property and shall comply with all applicable regulations for the installation, removal, and handling of such hazardous materials. The CONTRACTOR is solely responsible for protection of persons and property that could be affected by construction and the CONTRACTOR's handling of such materials.

4.5. OWNERSHIP OF PLANS, SPECIFICATIONS, SHOP DRAWINGS

All Plans, Specifications, shop drawings, other drawings, permits, reports, licenses, etc., used for this Project are the property of MCSD and shall not be used for any other work. Nothing in this Contract shall be construed to vest in CONTRACTOR any property right in any Plans, Specifications, shop drawings, other drawings, permits, reports, licenses, or other Project-related documents, nor shall the CONTRACTOR obtain any property right in any material, article or structure within the Project area which is in existence at the time the Contract is awarded or subsequently is furnished by the CONTRACTOR to MCSD and becomes a part of the Project.

4.6. PRESERVATION OF PROPERTY

The CONTRACTOR shall exercise reasonable care to avoid injury to existing improvements or facilities, utility facilities, any private or public property wherever located, trees, shrubbery and other landscaping which are not to be removed. The CONTRACTOR is required to familiarize itself with the worksite.

All trees, shrubbery, landscaping which are not to be removed, and pole lines, fences, signs, survey markers and monuments, buildings, structures and improvements, conduits, pipelines (under or aboveground), sewers, waterlines, highway or street facilities, and any other improvements or facilities with respect to any private or public property wherever located shall be protected from injury or damage. The CONTRACTOR shall provide and install suitable safeguards to protect such objects from injury or damage.

If such objects are injured or damaged by reason of the CONTRACTOR's operation, they shall be replaced or restored at the CONTRACTOR's expense to a condition equivalent to their condition prior to such injury or damage or as required by the Contract Documents.

The CONTRACTOR is obligated to respond to a notification of damages to any private or public property wherever located caused by CONTRACTOR's operations by beginning work on emergency repairs/restorations immediately, and in no event later than 4 hours from said notification and on non-emergency repairs/restorations within 72 hours of said notification. Within these required timeframes, the CONTRACTOR must begin efforts to resolve issues of responsibility for any damages or losses for any asserted claim. For any claims the CONTRACTOR asserts are not related to its operations, the CONTRACTOR must provide MCSD with written notice to MCSD stating its position and all documentation supporting the same, as well as written proof of referral to its insurance carrier and its determination, along with detailed rationale for any denial of coverage or denial of the claim. Said proof shall be submitted to MCSD within 30 days of the date of notification to the CONTRACTOR of the damages or losses.

In the event that the CONTRACTOR does not respond in the manner required herein and within the required timeframes, MCSD may determine the validity of the claim and perform the repair/restoration work itself or have another contractor or qualified entity perform the same, and CONTRACTOR's next progress payment shall be reduced in amount commensurate with the cost of the repair/restoration work and/or resulting damages as a Contract deduction. If the cost of the repair/restoration work and/or resulting damages exceeds the amounts remaining due under the Contract, CONTRACTOR shall reimburse MCSD for all remaining costs and/or damages immediately.

The fact that any pipe or other underground facility is not shown on the Contract Documents, or is shown in a different location, shall not relieve the CONTRACTOR of responsibility under this section. The CONTRACTOR shall be responsible for avoiding all injury or damage to any type of underground utility facility.

In addition to any requirements imposed by law, the CONTRACTOR shall shore up, brace, underpin, and protect as may be necessary, all foundations and other parts of all existing structures adjacent to and adjoining the worksite which are, or may be, in anyway affected by the excavations or other operations connected with the performance of the Work. Whenever any notice is required to be given by MCSD or the CONTRACTOR to any adjacent or adjoining landowner or other party before commencement of any Work, such notice shall be given by MCSD, unless the CONTRACTOR is directed otherwise by MCSD.

In an emergency affecting the safety of life or property, including adjoining property, the CONTRACTOR, without special instructions or authorizations, is authorized to act with discretion to prevent such threatened loss or injury.

4.7. PERSONAL LIABILITY

No director, officer, employee, or agent of MCSD, or its CONSULTANT, shall be personally responsible for any liability arising under or by virtue of the Contract.

4.8. WARRANTY OF TITLE

No materials, supplies or equipment for the Work under this Contract shall be purchased subject to any chattel mortgage or under a conditional sale contract or other agreement by which an interest therein or any part thereof is retained by the seller or Supplier. The CONTRACTOR warrants clear and good title to all materials, supplies, and equipment installed and incorporated in the Work and agrees, upon completion of all Work, to deliver the Work together with all improvements and appurtenances constructed or placed thereon to MCSD free from any claims, liens, encumbrances, or charges, and further agrees that neither the CONTRACTOR, nor any person, firm, or corporation furnishing any material or labor for any Work covered by the Contract shall have any right to a lien upon the premises or any improvement or appurtenance thereon, provided that this shall not preclude the CONTRACTOR from installing metering devices or other equipment of utility companies or of municipalities, the title to which is commonly retained by the utility company or the municipality.

Nothing contained in this section shall defeat or impair the right of such persons furnishing materials or labor, under any bond given by the CONTRACTOR for their protection, or any right under any law permitting such persons to look to unpaid funds due the CONTRACTOR in possession of MCSD. The provisions of this section shall be inserted in all subcontracts and material contracts, and notices of its provisions shall be given to all persons furnishing materials for the Work when no formal contract is entered into for such materials.

The CONTRACTOR is responsible for, and shall be obligated to pay, all stop payment notice claims asserted and proved to be an obligation of the CONTRACTOR.

4.9. PROPERTY RIGHTS IN MATERIAL

Nothing in these Contract Documents shall be construed as vesting in the CONTRACTOR any right of property in the materials used after they have been attached or affixed to the Work or the soil, or after payment has been made for materials delivered to the worksite or stored subject to or under the control of MCSD.

All such materials shall become the property of, and title shall pass to, MCSD upon being so attached or affixed or upon payment for materials delivered to the worksite or stored subject to or under the control of MCSD. The CONTRACTOR shall promptly execute, acknowledge and deliver to MCSD proper bills of sale or other written instruments of title in a form as required by MCSD. The written instrument of title shall convey to MCSD title to material, goods, and/or equipment for the Work free and clear of debts, claims, liens, mortgages, taxes and/or encumbrances. If title has not been vested in MCSD previously, title shall pass to MCSD upon Final Acceptance.

The CONTRACTOR at its own expense shall conspicuously mark such material, goods and equipment necessary for the Work as the property of MCSD, and shall not permit such material, goods and equipment necessary for the Work to become commingled with non-MCSD owned materials, equipment or goods, and shall take such other steps MCSD may require or regard as necessary to vest title to such material, goods and equipment necessary for the Work to MCSD free and clear of debts, claims, liens, mortgages, taxes and/or encumbrances.

Transfer of title of Work to MCSD shall not constitute or imply MCSD's acceptance of the Work. Notwithstanding the transfer of title, the CONTRACTOR shall continue to be liable and responsible to MCSD for any damage to or loss of Work until the Work achieves Final Acceptance, as defined herein.

Soil, stone, gravel and other materials found at the worksite and which conform to the Contract Documents for incorporation into the Work may be used in the Work. No other use shall be made of such materials except as may be otherwise described in the Contract Documents.

4.10. TERMINATION FOR DEFAULT

If the CONTRACTOR refuses or fails to prosecute the Work or any separable part thereof with such diligence as will ensure its completion within the time specified herein, or any authorized extension thereof, or fails to perform the Work in a manner required by the Contract Documents and/or industry standards, or fails to complete such Work within such time as required under the Contract Documents or, if the CONTRACTOR should be adjudged as bankrupt, or is otherwise deemed insolvent by MCSD based on good cause and is unable to proceed with the Work, or if the CONTRACTOR should make a general assignment for the benefit of creditors, or if a receiver should be appointed on account of insolvency, or if the CONTRACTOR files a petition to take advantage of any debtor's act, or should any Subcontractor violate any of the provisions of the Contract, or if the CONTRACTOR should persistently or repeatedly refuse or fail, except in cases for which an authorized extension of

time is provided, to supply enough properly skilled workers or proper materials to complete the Work in the time specified, or if the CONTRACTOR should fail to make prompt payment to Subcontractors for material or labor, or if the CONTRACTOR should persistently disregard laws, or instructions given by MCSD, or if the CONTRACTOR otherwise substantially fails to fulfill its obligations under the Contract Documents, MCSD may, without prejudice to any other right or remedy, serve written notice upon the CONTRACTOR and Sureties of MCSD's intention to terminate the CONTRACTOR's performance under the Contract. Said notice shall contain the reasons for such intention to terminate the CONTRACTOR's performance under the Contract, and unless, within ten (10) days after the service of such notice, such violations cease and/or satisfactory arrangements for the corrections thereof have been made, the MCSD may terminate CONTRACTOR's performance under the Contract and the CONTRACTOR shall not be entitled to receive any further payment until the Work is finished.

In the event of any such termination, MCSD shall serve written notice thereof upon the Surety and CONTRACTOR, and the Surety shall have the right to take over and perform the Contract. However, if the Surety, within five (5) days after the service of a notice of termination, does not give MCSD written notice of its intention to take over and perform the Contract, and if it serves such notice of its intent to take over and perform the Contract and does not begin performance thereof within fifteen (15) days from the date of serving said notice, MCSD may take over the Work and prosecute the same to completion by contract or by any other method it may deem advisable for the account and at the expense of the CONTRACTOR, and the Sureties and/or CONTRACTOR shall be liable to MCSD for any excess cost or other damage incurred by MCSD thereby. In such an event MCSD may without liability for so doing, take possession of and utilize such materials, tools, equipment, supplies and other property belonging to the CONTRACTOR and/or assume assignment of any and all subcontracts for Subcontractors and/or Suppliers that may be on the worksite and be necessary to complete the Work. For any portion of such Work that MCSD elects to complete by furnishing its own employees, materials, tools, and equipment, MCSD shall be compensated in accordance with the schedule of compensation for force account work as stated in the General Conditions section entitled Contract Price Adjustments and Payments.

If the Surety assumes the CONTRACTOR's terminated Work, it shall take the CONTRACTOR'S place in all respects for that part and shall be paid by MCSD for all Work performed by it in accordance with the terms of the Contract Documents. If the Surety assumes the entire Contract, all money due the CONTRACTOR at the time of its default shall be payable to the Surety as the Work progresses, subject to the terms of the Contract.

CONTRACTOR hereby consents to assigning to MCSD and/or MCSD's replacement contractor all subcontracts and other agreements of any and all Subcontractors and/or Suppliers that may be on the worksite and/or may be necessary to complete the Work in the event of Termination for Default or Termination for Convenience, as set forth below. CONTRACTOR agrees to obtain, by way of a subcontract provision, the consent of each and every Subcontractor and/or Supplier for such assignment prior to the commencement of each such Subcontractor's and/or Supplier's Work on the Project.

In the event of such termination, the CONTRACTOR will be paid the actual amount due based on unit prices or lump sums Bid and the quantity of Work completed at the time of termination, less damages caused to MCSD by acts of the CONTRACTOR causing the termination, including but not limited to, all costs to MCSD arising from professional services and attorneys' fees and all costs generated to insure or bond the Work of substituted contractors or subcontractors utilized to complete the Work, such excess shall be paid to the CONTRACTOR. If such costs exceed the unpaid balance, the CONTRACTOR shall pay the difference to MCSD promptly upon demand. On failure of the CONTRACTOR to pay, the Surety shall pay on demand by MCSD. Any portion of such difference not paid by the CONTRACTOR or Surety within thirty (30) days following the mailing of a demand for such costs shall earn interest at the maximum rate authorized by California law.

The CONTRACTOR and MCSD agree that nothing in this section is intended to be or is a prevailing party clause as it pertains to attorney's fees.

The foregoing provisions are in addition to and not in limitation of any other rights or remedies under law or in equity available to MCSD.

If it is later determined by MCSD that the CONTRACTOR had an excusable reason for not performing, such as a fire, flood, or other event which was not the fault of or was beyond the control of the CONTRACTOR, MCSD, after setting up a new performance schedule, may allow the CONTRACTOR to continue Work, or treat the termination as a termination for convenience, and the rights and obligations of the parties shall be the same as if the termination had been issued for the convenience of MCSD.

4.11. TERMINATION FOR CONVENIENCE

MCSD may terminate the CONTRACTOR's performance under the Contract, either in whole or in part, at its own discretion or when conditions encountered during the Work make it impossible or impracticable to proceed, or when MCSD is prevented from proceeding with the Contract by act of God, by law, or by official action of a public authority, or upon a determination that such termination is in the best interest and convenience of MCSD, or whenever MCSD is prohibited from completing the Work for any reason. MCSD shall provide no less than ten (10) days written notice of its intent to terminate the Contract for convenience, and shall provide the CONTRACTOR with consultation with MCSD prior to termination.

Upon receipt of such written notice of termination, the CONTRACTOR shall:

1. Stop Work as specified in the written notice;
2. Terminate all orders and Subcontractors except as necessary to complete Work which is not terminated;
3. If directed in writing by MCSD to do so, assign all right, title and interest in subcontracts and materials in progress, in which case MCSD will have the right at its discretion to settle, or pay any or all claims arising out of the termination of such

Subcontractors, but in no event shall recovery by any CONTRACTOR include lost profits for uncompleted portions of Work;

4. Deliver or otherwise make available to MCSD all data, Drawings, Specifications, reports, estimates, summaries and such other information and material as may have been accumulated by the CONTRACTOR in performing this Contract whether completed or in process;
5. Settle outstanding liabilities and claims with the approval of MCSD;
6. Complete performance of such part of the Work as has not been terminated; and
7. Take such other actions as may be necessary, or as may be directed by MCSD for the protection and preservation of the Project and/or property related to the Contract.

Upon receipt of MCSD's written notice of termination for convenience, and within a period of 30 to 60 days, as determined by the ENGINEER at the time of termination, the CONTRACTOR shall submit to the ENGINEER a Termination Proposal which shall include, but is not limited to, the CONTRACTOR's estimated costs to be incurred by the CONTRACTOR as a result of the termination for convenience, and as allowed by the Contract Documents, including all documentation to support such costs; the status of the Work at time of termination; the status of termination of the CONTRACTOR'S Subcontractor(s) and Supplier(s) agreement(s) including the amount of each said agreement, amount paid under each agreement up to the date of termination, and the amount that currently remains due and owing under each agreement for Work completed as of the date of termination, if any; a list, certified as to quantity and quality, of termination inventory not previously disposed of, excluding items authorized for disposition by the ENGINEER; and any other information and/or documentation as required by MCSD.

Upon receipt of MCSD's written notice of termination for convenience, the CONTRACTOR shall submit to the ENGINEER a request for Final Payment, pursuant to the requirements set forth herein. Such request shall be submitted promptly, but no later than sixty (60) days from the effective date of termination.

The Final Payment to the CONTRACTOR after termination for convenience shall be limited to amounts due and owing under the Contract at time of termination, including the following:

1. Any actual costs incurred by the CONTRACTOR for restocking charges;
2. The agreed upon price of protecting the Work in any manner, if any, as directed by MCSD;
3. The cost of settling and paying claims arising out of the termination of the Work under subcontract agreements or orders with MCSD's approval, as specified above, exclusive of the of the amounts paid or payable on account of goods delivered or Work furnished by Subcontractor prior to the effective date of the termination; and

4. The Contract Price allocable to the portion of the Work properly performed or goods supplied by the CONTRACTOR as of the date of termination, as determined in accordance with the within Sections herein entitled Payment – General and Contract Price Adjustments And Payments, reduced by any sums previously paid to the CONTRACTOR.

MCSD shall have the right to withhold any portion or the whole of the Final Payment under this provision in the event there are any outstanding claims for compensation asserted by MCSD against the CONTRACTOR, or by any third party against MCSD which arises out of the CONTRACTOR's Work.

4.12. NOTICE AND SERVICE THEREOF

Any notice required or given under the Contract shall be in writing, be dated, and signed by the party giving such notice or its duly authorized representative, and be served as follows:

If to MCSD, by personal delivery or by deposit in the United States mail, or by electronic telecommunication.

If to the CONTRACTOR, by personal delivery to the CONTRACTOR or to its authorized representative at the worksite or by deposit in the United States mail, or by electronic telecommunication.

If to the Surety or any other person, by personal delivery to the Surety or other person or by deposit in the United States mail or by electronic telecommunication.

All mailed notices shall be in sealed envelopes, shall be sent by certified mail with postage prepaid, return receipt requested, and shall be addressed to the addresses and addressees contained in the Contract Documents, or such substitute addresses which a party designates in writing and serves as set forth herein.

All electronic telecommunication, to be effective, shall have a date and time receipt acknowledgment, and shall be clearly identified as a contractual notice under this, and any other applicable, provision of the Contract.

4.13. PARTIAL INVALIDITY

In the event any article, section, paragraph, sentence, clause, or phrase (collectively referred to hereinafter as "Contract Elements" or singularly as "Contract Element") contained in the Contract Documents shall be determined, declared, or adjudged invalid, illegal, unconstitutional, or otherwise unenforceable, such determination, declaration, or adjudication shall in no manner affect the other Contract Elements, which shall remain in full force and effect as if the Contract element declared, determined, or adjudged invalid, illegal, unconstitutional, or otherwise unenforceable, was not originally contained in the Contract Documents.

4.14. WAIVER OF RIGHTS

Except as otherwise specifically provided in the Contract Documents, no action or failure to act by MCSD, ENGINEER or CONTRACTOR shall constitute a waiver of any right or duty afforded any of them under the Contract Documents, nor shall any such actions or failure to act constitute an approval of or acquiescence in any breach thereunder.

4.15. TAXES

The CONTRACTOR shall pay all sales, consumer, use and other taxes.

4.16. ASSIGNMENT OF ANTITRUST ACTIONS

In entering into a public works contract or subcontract to supply goods, services or materials pursuant to a public works contract, the CONTRACTOR or Subcontractor offers and agrees to assign to MCSD all rights, title and interest in and to all causes of action it may have under Section 4 of the Clayton Act (15 U.S.C.A. Section 15), or under the Cartwright Act (Chapter 2 [commencing with Section 16700] of Part 2 of Division 7 of the California Business and Professions Code), arising from purchases of goods, services or materials pursuant to the public works contract or subcontract. This assignment shall be made and become effective at the time MCSD tenders Final Payment to the CONTRACTOR, without further acknowledgment by the parties.

In submitting a Bid to MCSD, the Bidder offers and agrees that if the Bid is accepted, it will assign to MCSD all rights, title, and interest in and to all causes of action it may have under Section 4 of the Clayton Act (15 U.S.C.A. Section 15), or under the Cartwright Act (Chapter 2 [commencing with Section 16700] of Part 2 of Division 7 of the California Business and Professions Code), arising from purchases of goods, materials or services by the Bidder for sale to the purchasing body, pursuant to the Bid. Such assignment shall be made and become effective at the time MCSD tenders Final Payment to the Bidder.

4.17. SUBCONTRACTING

If the CONTRACTOR subcontracts any part of the Contract, the CONTRACTOR shall be as fully responsible to MCSD for the acts, errors and omissions of the Subcontractor(s) and Suppliers and of the person(s) either directly or indirectly employed by the Subcontractor(s) and Suppliers as the CONTRACTOR is for the acts, errors and omissions of persons directly employed by the CONTRACTOR. Nothing contained in the Contract Documents shall create any contractual relationship between any Subcontractor/Supplier and MCSD. The divisions and sections of the Specifications and the identifications of any Drawings shall not control the CONTRACTOR in dividing the Work among Subcontractors.

4.18. FLOW-DOWN REQUIREMENTS

Each Subcontract and Supplier agreement shall preserve and protect the rights of MCSD, its directors, officers, agents, and employees under the Contract Documents with respect to the

Work to be performed by the Subcontractor so that subcontracting thereof will not prejudice such rights, and shall allow to the Subcontractor or Supplier, unless specifically provided otherwise in the subcontract agreement, the benefits of all rights, remedies and redress against the CONTRACTOR that the CONTRACTOR, by the Contract Documents, has against MCSD. Where appropriate, the CONTRACTOR shall require each Subcontractor and Supplier to enter into similar agreements with sub-Subcontractors. The CONTRACTOR shall make available to each proposed Subcontractor or Supplier, prior to the execution of the subcontract, copies of the Contract Documents. In addition, upon the request of MCSD, the CONTRACTOR shall make available to MCSD any and all Subcontract and Supplier agreements pertaining to the Project and the Work thereunder. By appropriate agreement, written where legally required for validity, the CONTRACTOR shall require:

1. Each Subcontractor and Supplier to be bound to the CONTRACTOR by the terms of the Contract Documents;
2. Each Subcontractor and Supplier shall assume toward the CONTRACTOR all obligations and requirements and responsibilities, including the responsibility for safety of the Subcontractor's Work, which the CONTRACTOR, by the Contract Documents, assumes toward MCSD;
3. Each Subcontractor and Supplier shall require all subcontracted Work to be performed in accordance with the Contract Documents and that with respect to the Work the Subcontractor or Supplier performs that the Subcontractor or Supplier assume toward the CONTRACTOR all the obligations and responsibilities which the CONTRACTOR assumes toward MCSD.
4. Each of its Subcontractors or Suppliers to include in their contracts with lower-tier Subcontractors or Suppliers these same requirements, and to require each Subcontractor or Supplier to make copies of the Contract Documents available to the Sub-Subcontractors or sub-Suppliers.

This section does not and shall not operate to relieve the CONTRACTOR of any duty or liability under the Contract Documents, nor does it create any duty or liability on the part of MCSD. The CONTRACTOR shall have sole responsibility for promptly settling any disputes between its Subcontractors and between the Subcontractors and any of their lower-tier Subcontractors.

4.19. ASSIGNMENT

The performance of all or any portion of the Contract may not be assigned except upon the written consent of MCSD, and as specifically provided herein. Consent will not be given to any proposed assignment that would relieve the original CONTRACTOR or the Sureties of responsibilities under the Contract.

Upon obtaining prior written consent of MCSD, the CONTRACTOR may assign monies due or to become due under the Contract, to the extent permitted by law, but any assignment of

monies shall be subject to all proper setoffs in favor of MCSD and to all deductions provided for in the Contract. In particular, all monies withheld, whether assigned or not, shall be subject to being used by MCSD for the completion of the Work in the event that the CONTRACTOR should default.

No assignment of the Contract will be approved unless it contains a provision that the funds to be paid to the assignee under the assignment are subject to a prior lien for services rendered or materials supplied for performance of the Work called for under the Contract in favor of all persons, firms, or corporations rendering such services or supplying such materials and that MCSD may withhold funds due until all Work required by the Contract Documents is completed to MCSD's satisfaction.

4.20. WARRANTY (CONTRACTOR'S GUARANTEE)

- A. The CONTRACTOR shall and hereby does guarantee the entire Work, and its performance through maintenance of sufficient warranties, that the entire Work shall perform at all times as part of a fully integrated system consisting of all Work elements specified in the Contract Documents for a period of one (1) year after the Final Acceptance of the Work by MCSD. Any portion of the Work that is Beneficially Occupied shall be additionally warranted as described, in these General Conditions, Use Prior to Final Completion (Beneficial Occupancy). During the warranty period, the CONTRACTOR shall repair or remove and replace any Work, together with any other work which may be displaced in so doing that is found to be defective in workmanship and/or materials without any expense to MCSD, ordinary wear and tear and unusual abuse or neglect excepted. In the event of failure to comply with the above-mentioned conditions within one (1) week after being notified in writing, MCSD is hereby authorized to proceed to have the defects remedied at the expense of the CONTRACTOR who hereby agrees to pay the cost and charges thereof immediately on demand. The CONTRACTOR's warranty shall continue as to any corrected deficiency until the later of:
1. The remainder of the original one-year warranty period; or
 2. One year after acceptance by MCSD of the corrected Work.
- B. Such action by MCSD will not relieve the CONTRACTOR of the warranties required by this section or elsewhere in the Contract Documents.
- C. All guarantees and warranties, expressed or implied shall inure to the benefit of both MCSD and the CONTRACTOR during the performance of the Work. Upon Final Completion of the Work, such guarantees and warranties shall inure to the benefit of MCSD.
- D. The Performance Bond and the Payment Bond shall continue in full force and effect for the warranty period, including all extensions thereof as provided by the Contract Documents.

- E. If, in the opinion of MCSD, defective Work is detected during the warranty period which creates a dangerous condition or requires immediate correction or modification to prevent further loss to MCSD or to prevent interruption of MCSD operations, MCSD will attempt to give the notice required by this section. If the CONTRACTOR cannot be contacted or does not comply with MCSD's request for correction within a reasonable time as determined by MCSD, MCSD may, notwithstanding the provisions of this section, proceed to make such correction or provide such modification. The costs of such correction or modification shall be charged against the CONTRACTOR. Such action by MCSD will not relieve the CONTRACTOR of the warranties required by this section or elsewhere in the Contract Documents.
- F. This section does not in any way limit the warranty on any items for which a longer warranty is specified or on any items for which a manufacturer or Supplier gives a warranty for a longer period. The CONTRACTOR agrees to act as a co-guarantor with such manufacturer or Supplier and shall furnish MCSD all appropriate guarantee or warranty certificates upon completion of the Project and acceptance by MCSD. No warranty period, whether provided for in this section or elsewhere, shall in any way limit the liability of the CONTRACTOR, Sureties or insurers.

4.21. SAFETY PRECAUTIONS AND EMERGENCIES

A. CONTRACTOR's Responsibility for Safety.

CONTRACTOR shall be responsible for initiating, maintaining and supervising all safety precautions and programs in connection with the Work. This requirement will apply continuously twenty four hours a day every day until Final Acceptance of the Work and shall not be limited to normal working hours. The duties of MCSD, Engineer and Inspector do not include review of the adequacy of CONTRACTOR's safety measures in, on, or about the site and vicinity.

B. Safety Officer.

Contractor shall designate a responsible member of its organization at the site of the Work whose duty shall be the prevention of hazards and accidents. This person shall be CONTRACTOR's Superintendent unless otherwise designated in writing by CONTRACTOR to the ENGINEER.

C. Safety Measures.

Contractor shall comply with all Codes and lawful orders of any public authority having jurisdiction for the safety of persons or property or to protect them from damage, injury or loss. Contractor shall comply with the "Manual of Accident Prevention in Construction" published by the Associated General Contractors of America, Inc., including the recommendations for safe construction methods and the requirements for the guarding of machinery and equipment therein, to the extent that the provisions of the manual are not in conflict with applicable Codes and orders. CONTRACTOR shall maintain copies of all

documents mentioned or referenced in this paragraph readily available at the site until the Work is completed.

D. Warnings and Barricades.

CONTRACTOR shall provide and maintain barricades, guards, temporary bridges and walkways, watchmen, night lights and danger signals illuminated from sunset to sunrise, and all other necessary appliances and safeguards to protect the Work, life, property, the public, excavations, equipment, and materials. Barricades shall be of substantial construction and shall be painted such as to increase their visibility at night. Suitable warning signs shall be so placed and illuminated at night as to show in advance where construction, barricades, or detours exist. Guard rails shall be provided for bridges and walkways over or adjoining excavations, shafts, and other openings and locations where injury may occur.

E. Fire Prevention.

CONTRACTOR's Safety Officer shall inspect the entire Work and site, including storage areas, at frequent intervals to verify that fire prevention measures are constantly enforced.

F. Flammable or Toxic Materials.

Only a working supply of flammable or toxic materials shall be permitted in or on any of the permanent structures and improvements, and shall be removed therefrom at the end of each day's operations. CONTRACTOR shall store flammable or toxic materials and waste separate from the Work and stored materials for the Work in a manner that prevents spontaneous combustion or dispersion, and none shall be placed in any sewer or drain piping nor buried on the Owner's property.

G. Safety Helmets, Clothing, and Equipment.

CONTRACTOR shall not permit any person for whom he is responsible or liable to enter or remain on the site of the Work unless the person is equipped with and wearing a safety helmet and other protective clothing and safety equipment conforming to the requirements of paragraph C. "Safety Measures," and shall discharge from the site all persons not so equipped.

H. Hazardous Areas.

CONTRACTOR shall not permit or allow any person or persons to enter any pipe or space containing hazardous or noxious substances or gases, or where there is an insufficient amount of oxygen to sustain life and consciousness, or any other hazardous area unless equipped with lawful and appropriate safety equipment and life supporting apparatus, and unless those entering are continually monitored and guarded by and in communication with other persons outside the space or area who are equipped in the same way, can give an alarm to others for assistance, and initiate immediate rescue operations in the event of mishap.

I. Emergencies.

CONTRACTOR shall perform any and all operations and shall furnish any materials and equipment necessary during an emergency endangering life or property and, in all cases, shall notify the ENGINEER of the emergency as soon as practicable, but shall not wait for instruction before proceeding to properly protect both life and property.

CONTRACTOR shall file with the ENGINEER a written list giving the names, addresses, and telephone numbers of at least two of his representatives who can be contacted at any time in case of emergency. The representatives shall be fully authorized and equipped to correct unsafe or inconvenient conditions on short notice. CONTRACTOR shall promptly notify the ENGINEER of all changes in the listing.

5. SCOPE OF WORK

5.1. GENERAL

The intent of the Contract Documents as they apply to the Project is to prescribe and provide for the complete and finished performance and accomplishment, in every respect, of the entire contemplated Work indicated in the Contract Documents, relating directly to the Project. It shall be understood that the CONTRACTOR undertaking the execution of all or any part of such Work shall be required to perform in a craftsman-like manner and in strict compliance with Contract Documents, and to furnish and provide in connection therewith all transportation, labor, tools implements, equipment, materials, supplies, services and other items which are necessary or appurtenant to construct and complete the entire Project, including but not limited to all applicable codes, permits, ordinances, regulations, and laws.

5.2. CONSTRUCTION PROCEDURES AND PROTECTION

A. CONTRACTOR's Plant and Equipment.

CONTRACTOR shall furnish modern plant and equipment as necessary to perform the Work in a manner satisfactory to the ENGINEER and in accordance with the Contract Documents, types and designs that comply with the requirements herein and with the requirements prescribed by Codes pertaining to wind and seismic forces at the place of the Project. Construction equipment or machinery that at any time produces unsatisfactory results shall be promptly repaired or replaced by the Contractor and as the ENGINEER may require.

B. Use of Site.

CONTRACTOR shall confine its equipment, the storage of materials and equipment, and the operations of those directly and indirectly employed by it to areas permitted by applicable Codes and the Contract Documents, and shall not unreasonably encumber the

site with materials and equipment. Nothing in the Contract Documents shall grant to the Contractor exclusive occupancy of the site of the Work and Project.

C. Overloading.

No part of the Work or new and existing structures, scaffolding, shoring, sheeting, construction machinery and equipment, or other permanent and temporary facilities shall be loaded with weights or subjected to stresses or pressures that endanger any of them. CONTRACTOR shall bear the cost of correcting damage caused by overloading or excessive stresses or pressures.

D. Use of Explosives.

CONTRACTOR shall comply with all laws, ordinances, regulations, codes, and orders governing the transportation, storage, and use of explosives, shall exercise extreme care not to endanger life or property, and shall be responsible for all injury or damage resulting from the use of explosives for or on the Work. No blasting shall be done in the vicinity of existing structures above or below the ground without the prior written consent of the owner thereof.

E. Cutting and Patching.

CONTRACTOR shall perform all cutting, fitting, or patching of the Work that may be required to make its several parts fit together properly and satisfactorily, and shall not endanger any Work, structures, adjacent property, workmen, or the public by cutting, excavating, or otherwise altering the Work or any part of it. CONTRACTOR shall restore all such cut or patched Work and improvements as approved by the ENGINEER.

F. Verification of Installed Work.

CONTRACTOR shall correct all defects in installed Work of the Contract before subsequent related or connected Work is applied or installed. Where the Contract Documents require a material or item of equipment to be applied or installed under the supervision, inspection, or direction of the supplier or manufacturer, or his representative, the supplier, manufacturer, or his representative shall inspect the applicable installed Work and issue a letter to the ENGINEER stating the corrections required to or approval of the installed Work before his material or equipment is installed or applied.

G. Manufacturers' Instructions.

Unless otherwise provided in the Contract Documents, CONTRACTOR shall apply, install, erect, connect, use, clean, condition, and operate manufactured articles, materials, and equipment in accordance with the various manufacturers' instructions. CONTRACTOR shall compare the requirements of the various manufacturers' instructions with the requirements of the Contract Documents, shall promptly notify the ENGINEER in writing of any difference between such requirements, and shall not proceed with any of the Work affected by such differences until an interpretation or clarification is issued.

CONTRACTOR shall bear all costs for any error in the Work resulting from its failure to so compare the various requirements and notify the ENGINEER of any such differences.

H. Public Convenience.

CONTRACTOR shall at all times so conduct its operations as to ensure the least possible obstruction and inconvenience to traffic and the general public and the residents in the vicinity of the Work, to protect persons and property, and to preserve access to driveways, house, and buildings. CONTRACTOR shall have under construction no greater amount of Work than it can properly perform with due regard to the rights of the public, and shall not create any public nuisance. No road, street, or highway shall be closed to the public except with the permission of the proper authorities. Where existing streets are not available as detours, CONTRACTOR shall permit traffic to safely pass through the Work with as little delay and inconvenience as possible, unless otherwise authorized by the ENGINEER. CONTRACTOR shall furnish competent flagmen whose sole duty shall be the directing of traffic through or around the Work when ordered by the ENGINEER, required by public authorities having jurisdiction, or required by law. At no time shall CONTRACTOR prevent free access to fire hydrants, water and gas main valves, manholes or vaults, or other utility facilities except as otherwise required to perform the Work and in compliance with all Codes and permits. CONTRACTOR shall make temporary provisions to ensure the use of walkways and sidewalks and the proper functioning of gutters, sewer and storm drain inlets, and ditches, which shall not be obstructed.

I. Protection.

CONTRACTOR shall take all precautions and furnish and maintain protection to prevent damage, injury, or loss to all employees and workmen on the Work and all other persons who may be affected thereby; all the Work and all materials and equipment to be incorporated therein, whether in storage on or off the site, under the care, custody or control of CONTRACTOR or any of its Subcontractors; and other improvements and property at the site or where Work is to be performed including buildings, trees and plants, pole lines, fences, guard rails, guide posts, culvert and project markers, signs, structures, conduits, pipe lines, and improvements within or adjacent to streets, rights of way, or easements, except those items required to be removed by the Contractor in the Contract Documents. The Contractor's protection shall include all the safety precautions required under General Conditions Section entitled "Safety Precautions and Emergencies" and other necessary forms of protection, and the notification of the owners of utilities and adjacent property.

Unless otherwise provided in the Contract Documents or unless otherwise cared for by the owner thereof, all water, gas, oil, or irrigation lines, all lighting, power, communication, or telephone conduits, all sewer and drainage lines and house connection lines, sprinkling systems, and other subsurface structures of any nature along the Work shall be maintained by CONTRACTOR at its expense, and shall not be disturbed, disconnected, or damaged by CONTRACTOR during the progress of the Work. CONTRACTOR shall install temporary pipes of adequate size to carry off sewage from any sewer facilities cut off by construction operations. Installation of temporary pipes shall be made immediately upon cutting of the existing facility, and no sewage shall be allowed to flow from any severed

facility upon the ground surface or in the trench excavation. Pipe used in temporary sewers may be clay, metal, concrete, or composition. Before completion of Work, CONTRACTOR shall replace all severed connections and restore to operating order the existing sanitary facilities with matching materials and construction. No liquid from any severed facility shall be allowed to flow upon the ground surface or in any excavation.

Except for those improvements and facilities required to be permanently removed by the Contract Documents, CONTRACTOR shall make satisfactory and acceptable arrangements with the appropriate owners and, at its expense, shall repair and restore all improvements, structures, property, utilities, and facilities disturbed, disconnected, or damaged as a result or consequent of its Work or the operations of those for whom he is responsible or liable, including that caused by trespass of any of them with or without his knowledge or consent, or by the transporting of workmen, materials, or equipment to or from the site.

5.3. ERRORS AND OMISSIONS

The CONTRACTOR, as part of this Contract, shall agree not to take advantage of errors or omissions in the Contract Documents. It is the duty of the CONTRACTOR to promptly notify the ENGINEER in writing of any design, materials, or specified method that the CONTRACTOR believes may prove defective or insufficient. If the CONTRACTOR believes that a defect or insufficiency exists in design, materials or specified method and fails to promptly notify the ENGINEER in writing of this belief, the CONTRACTOR thereby waives any right to assert that defect or insufficiency in design, materials or specified method at any later date in any legal or equitable proceeding against MCSD, or in any subsequent arbitration or settlement conference between MCSD and the CONTRACTOR. The ENGINEER, upon receipt of any such notice, will promptly investigate the circumstances and give appropriate instructions to the CONTRACTOR. Until such instructions are given, any Work done by the CONTRACTOR after the CONTRACTOR becomes aware that a defect or insufficiency exists in design, materials or specified method which is directly or indirectly affected by such alleged defect or insufficiency in design, materials or specified method will be at the CONTRACTOR's own risk and the CONTRACTOR shall bear all costs arising therefrom. In the event the CONTRACTOR believes that the ENGINEER's instruction results in a change to the Contract Documents or Work requiring a change to the period of Contract performance or Contract Price, CONTRACTOR must submit a Request for Change in the time and manner set forth in the Section herein entitled Request for Change (Changes at CONTRACTOR's Request).

If the CONTRACTOR, either before commencing Work or in the course of the Work, finds any discrepancy between the Contract Documents, or the physical conditions at the worksite, or finds an error or omission on the Plans or in any survey, the CONTRACTOR shall promptly notify the ENGINEER in writing of such discrepancy, error or omission. If the CONTRACTOR observes that the Contract Documents are at variance with any applicable law, regulation, order, or decree, the CONTRACTOR shall promptly notify the ENGINEER in writing of such conflict. The ENGINEER, on receipt of such notice, will promptly investigate the circumstances and give appropriate instructions to the CONTRACTOR. Until

such instructions are given, Work done by the CONTRACTOR after the discovery of such error, discrepancy, or conflict which is directly or indirectly affected by such error, discrepancy, omission or conflict will be at the CONTRACTOR's own risk and the CONTRACTOR shall bear all costs arising therefrom. In the event the CONTRACTOR believes that the ENGINEER's instruction results in a change to the Contract Documents or Work requiring a change to the period of Contract performance or Contract Price, CONTRACTOR must submit a Request for Change in the time and manner set forth in the Section herein entitled Request for Change (Changes at CONTRACTOR's Request).

Any Work or material not herein specified or shown on the Contract Documents, but which by fair implication in the judgment of the ENGINEER, should be included therein, shall be accomplished or furnished by the CONTRACTOR as part of the Contract requirements.

5.4. REQUEST FOR CHANGE (CHANGES AT CONTRACTOR'S REQUEST)

A. General

The CONTRACTOR may request an equitable adjustment if it considers any Work which is demanded by the ENGINEER in writing to be "Extra Work" and outside the requirements of the Contract Documents or in variance to the same, or otherwise causes the CONTRACTOR to accelerate or decelerate the Work or causes a delay to the Work. Equitable adjustments may also be requested if the CONTRACTOR identifies what it believes to be errors or omissions of any kind, including design errors or omissions, in the Contract Documents or encounters a differing site condition that could not reasonably have been foreseen, and any such occurrence or direction materially changes the Contract Documents or Work and/or which may require a change to the period of performance or Contract Price (either additive or deductive). The CONTRACTOR shall within three (3) days after any such demand, instruction, ruling, occurrence, discovery, or decision is made, notify the ENGINEER in writing by way of a document entitled "Request for Change" (RFC). The RFC shall set out in specific detail all objections such as why the requested Work is not in the scope of the Contract Documents and the reasons therefore, and/or the reason why the required Work is outside the scope of the Contract Documents, the identification of the Contract Document, term, condition, or specification proposed to be altered, changed, added, or deleted, and why the CONTRACTOR believes additional compensation or time will or may be due as a result thereof.

Except for RFCs which are made in the manner and within the time stated above, the CONTRACTOR shall be deemed to have waived, and does by execution of the Contract knowingly waive all Claims for Extra Work, damages and extensions of time resulting from demand, instructions, rulings and decisions of the ENGINEER. Except for requests for equitable adjustment based on defective Specifications, no requests for equitable adjustment hereunder shall be allowed for any costs incurred more than 3 days before the CONTRACTOR gives written notice as required herein. In the case of defective Specifications for which MCSD is responsible, if there are any increased direct costs reasonably incurred by CONTRACTOR in attempting to comply with those defective Specifications, CONTRACTOR will be entitled to recovery of any such increased direct

costs if the Request for Change is made in accordance with the procedures set forth herein, Request for Change (Changes At CONTRACTOR's Request) and/or OWNER Initiated Changes. CONTRACTOR, however, is not relieved of its obligation at time of Bid to have reviewed the Contract Documents and identified any patent errors or omissions in the same; and it shall bear all costs arising from any such failure.

B. Request for Change Submissions; Cost and Schedule Proposals

All RFCs shall be dated, numbered sequentially, and shall describe the action or event which the CONTRACTOR believes may require equitable adjustment. The CONTRACTOR shall also provide a description of possible CONTRACTOR actions or solutions to minimize the cost of the RFC, and it shall provide a cost and schedule proposal for said Work based upon an estimate of the cost for the anticipated changed Work, and shall submit said price and time impact to the ENGINEER whose approval shall be secured before Work is started. The cost and schedule proposal shall include, at a minimum, the following:

1. A detailed cost breakdown of the changed Work organized and subtotaled by specification section in a spreadsheet format specified by the ENGINEER itemizing all costs associated with the Extra Work, deletion or revision, including material, labor, equipment, etc. in a manner evidencing the logical computation and allocation of costs, and the CONTRACTOR must also include all necessary back-up documentation including quantities, labor man-hours, unit prices, and Supplier and Subcontractor quotations to support said estimate, and any other data, information and/or documentation required by the ENGINEER. Costs for preparing cost or schedule proposals are not compensable.
2. If an adjustment to the Contract period of performance is requested, the delay must be substantiated and documented by the CONTRACTOR. In accordance with the schedule requirements in the Specifications, an accurately updated Project schedule proving time impacts and actual delay to critical path activity is required, unless otherwise directed in writing by the ENGINEER, and shall be accompanied by any and all documentation as more particularly specified herein, General Conditions, Extension of Time for Delay. The CONTRACTOR shall also include the identification of labor, materials and/or other cost items including overhead and Subcontractor costs, which have been or may be added, deleted or wasted by such delay, and a statement that the CONTRACTOR is maintaining records which allows the separately identifiable direct costs due to the delay, and those not incurred as a result of the delay, to be readily identifiable and segregated.
3. In addition, the CONTRACTOR shall include with its cost and/or schedule proposal a certification, executed by a duly authorized representative of the CONTRACTOR, stating the following, or the RFC shall be considered incomplete and shall not be accepted by MCSD:

“I certify that (1) the Request for Change is made in good faith, (2) I have reviewed all supporting documentation and data, which is included herewith, and it is accurate and complete, (3) I have determined from my independent review of the Request for Change that the same is meritorious, and that the amount and/or time extension requested accurately reflects the Contract adjustment for which I believe MCSD is liable; and (4) I am duly authorized to certify the Request for Change on behalf of the CONTRACTOR.”

4. CONTRACTOR shall submit three printed copies of the complete proposal along with an electronic copy of the proposal on a compact disc in a file format acceptable to MCSD.

Extra Work shall be priced by CONTRACTOR and paid by MCSD consistent with the allowable costs set forth in the Section herein entitled “Contract Price Adjustments and Payment.”

Upon receipt of the CONTRACTOR’s RFC, the ENGINEER shall review the same and shall promptly advise the CONTRACTOR in writing of the final decision. The final decision shall be binding, subject however to the approval of the Board of Directors or General Manager, to the extent the final decision changes the Contract Documents and a Change Order is required. If additional information is needed to evaluate the Request for Change, the ENGINEER may at its sole discretion request that the CONTRACTOR submit such additional information or documentation as may be needed to evaluate the RFC. By issuing any request for additional information, the ENGINEER shall not be deemed to have made a determination as to the merit of the CONTRACTOR’s Request for Change or as to the nature of the Work in question, and in no event shall it be deemed a direction to proceed with said Work. The CONTRACTOR shall submit any further information or documentation requested by the ENGINEER, whose approval shall be secured before Work is started. In the event negotiations are necessary to determine an appropriate cost and/or schedule adjustment to the Contract, the CONTRACTOR shall negotiate in good faith with the MCSD.

C. Authority to Direct Extra Work

The ENGINEER may, when in the best interest of MCSD issue a Change Order to the CONTRACTOR to proceed with the Extra Work including the Work identified in the RFC in advance of its cost and schedule proposal submission. MCSD reserves the right to reject any requests for equitable adjustment for Extra Work or for additional payment requested as a result of extending the Work under the Bid prices which has not been approved by the ENGINEER in the manner herein provided.

When the price for Extra Work, deletions or other revisions cannot be agreed upon, or the CONTRACTOR fails or refuses to negotiate in good faith with respect to the same, MCSD may issue a unilateral change using its independent estimate and time impact analysis, as more particularly specified in these General Conditions, Contract Price Adjustments and

Payments. MCSD may also direct such Work on a time and materials or force account basis.

To the extent the ENGINEER directs Extra Work to be performed on a time and materials or force account basis, such Extra Work shall be performed by the CONTRACTOR, and compensated by MCSD, in the time and manner set forth in General Conditions Section entitled, "Contract Price Adjustments and Payments," Sub-section D thereto, "Time & Material and Force Account Work."

In the event the CONTRACTOR disagrees with any findings made by the ENGINEER as it concerns entitlement to a Change Order, or any portion thereof, additional compensation under the Contract, or adjustment to period of performance, CONTRACTOR shall proceed with the Claims procedures set forth herein. CONTRACTOR also agrees to diligently proceed with the performance of the Contract, including the delivery of goods or providing of services in accordance with ENGINEER's instructions. CONTRACTOR's failure to diligently proceed in accordance with ENGINEER's instructions shall be considered a material breach of the Contract.

D. Minor Changes

Changes in the Work not materially affecting the efficiency or usability of the finished facility, which do not involve extra or lesser cost, and are not inconsistent with the intent of the Contract Documents or detrimental to the Project or to the interests of MCSD, may be granted by the ENGINEER to facilitate the Work of the CONTRACTOR when such changes are requested, in writing, and submitted to the ENGINEER for approval. In the event such changes are granted in writing by the ENGINEER, the changes shall be made without additional cost to MCSD. The CONTRACTOR will be responsible for all costs associated with future changes or conflicts that are caused by the CONTRACTOR's requested change. It shall be understood that nothing herein shall be construed as granting permissive rights to the CONTRACTOR to demand acceptance of such requested changes.

5.4. OWNER INITIATED CHANGES

A. General

MCSD reserves and shall have the right, without invalidating the Contract and without notice to the Surety(ies), to have changes made within the general scope of the Contract Documents consisting of Extra Work, deletions or other revisions. The signing of the Contract Documents by the CONTRACTOR will be deemed to be an agreement on its part to perform Extra Work, as and when ordered by the ENGINEER.

Upon decision of MCSD to have Extra Work performed, the ENGINEER will so inform the CONTRACTOR, acquainting the CONTRACTOR with the essential details of the Extra Work and issue a Request for Proposal ("RFP"). The CONTRACTOR shall thereupon, and within three (3) days, prepare a proposal for said Extra Work based upon an estimate of cost and submit said price and time impact analysis to MCSD whose

approval shall be secured before Extra Work is started. The ENGINEER may, when in the best interests of MCSD, order the CONTRACTOR to proceed with the Extra Work in advance of proposal submission. MCSD reserves the right to reject any Claims for Extra Work or for additional payment claimed as a result of extending the Work under the Bid prices which have not been approved by the ENGINEER in the manner herein provided.

B. Cost and Schedule Proposal

The CONTRACTOR's proposal must include, at a minimum, the items identified in the Section entitled "Request For Change (Changes At CONTRACTOR's Request)," subsection B.1 through B.4.

Extra Work shall be priced by CONTRACTOR and paid by MCSD consistent with the allowable costs set forth in the Section herein entitled "Contract Price Adjustments and Payment."

The ENGINEER shall review the CONTRACTOR's RFP submission of costs and/or delays and shall promptly advise the CONTRACTOR in writing of the final decision as to the adjustment to the Contract Price and/or period of performance, if any, to be made in the Contract Documents. The CONTRACTOR shall submit any further information or documentation requested by the ENGINEER, whose approval shall be secured before Extra Work is started. In the event negotiations are necessary to determine an appropriate cost and/or schedule adjustment to the Contract, the CONTRACTOR shall negotiate in good faith with MCSD. The ENGINEER's final decision shall be binding, subject however to the approval of the Board of Directors or General Manager, to the extent the final decision changes the Contract Documents and a Change Order is required.

C. Authority to Direct Extra Work

The ENGINEER may, when in the best interests of MCSD, order the CONTRACTOR to proceed with the Extra Work in advance of its cost and schedule proposal submission. MCSD reserves the right to reject any Claims for Extra Work or for additional payment claimed as a result of extending the Work under the Bid prices which has not been approved by the ENGINEER in the manner herein provided.

When the price for Extra Work, deletions or other revisions cannot be agreed upon, or the CONTRACTOR fails or refuses to negotiate in good faith with respect to the same, MCSD may issue a unilateral change using its independent estimate and time impact analysis, as more particularly specified in these General Conditions, Contract Price Adjustments and Payments. MCSD may also direct such Extra Work on a time and materials or force account basis.

To the extent the ENGINEER directs Extra Work to be performed on a time and materials or force account basis, such Extra Work shall be performed by the CONTRACTOR, and compensated by MCSD, in the time and manner set forth in General Conditions Section

entitled, "Contract Price Adjustments and Payments," "Time & Material and Force Account Work."

In the event the CONTRACTOR disagrees with any findings made by MCSD as it concerns adjustment to Contract Price or period of performance, CONTRACTOR shall proceed with the Claims procedures set forth herein. CONTRACTOR also agrees to diligently proceed with the performance of the Contract, including the delivery of goods or providing of services in accordance with MCSD's instructions. CONTRACTOR's failure to diligently proceed in accordance with MCSD's instructions shall be considered a material breach of the Contract.

D. Minor Changes

The ENGINEER may order in writing minor changes in the Work not involving an increase or decrease in the Contract Price, not involving a change in the time for completion, and not inconsistent with the Contract Documents or the purposes for which the Work is being constructed. If the CONTRACTOR believes that any order for minor changes in the Project involves changes in the Contract Price or time for completion, the CONTRACTOR shall not proceed with the minor changes so ordered and shall within three (3) days of the receipt of such order notify ENGINEER in writing of the estimate of the changes in the Contract Price and period of performance believed to be appropriate, and in the manner more particularly set forth herein at Request for Change (Changes At CONTRACTOR's Request).

5.5. CLAIMS

A. Claims Subject to Public Contract Code Section 20104, et seq.

For any Claim subject to Public Contract Code Section 20104 et seq., for Three Hundred Seventy-Five Thousand Dollars (\$375,000) or less, MCSD and CONTRACTOR shall comply with Public Contract Code Section 20104, et seq., for resolution.

B. Notice of Claim

Notwithstanding California Public Contract Code Section 20104.2(a), all Claims shall be filed with MCSD within twenty (20) days of MCSD's decision, act or omission which gives rise to the Claim, or prior to Final Completion, whichever occurs first. This notice requirement is specifically authorized by California Public Contract Code Section 20104.2(a). Unless such Claim is made and filed as herein prescribed, the Claim shall be forfeited and invalidated and the CONTRACTOR shall not be entitled to any relief, damages and/or payment in connection therewith. The presentation of such Claim, however, shall not be deemed evidence of any liability for the alleged damage on the part of MCSD or MCSD agent.

C. Claims Not Subject to Public Contract Code Section 20104, et seq.

For any Claim, including any disagreement between the parties as to the merits, amount or remedy arising from the Project or Contract Documents not subject to Public Contract Code Section 20104, et seq., the provisions of Public Contract Code Section 20104, et seq., are hereby incorporated and shall apply to all such Claims except as follows:

1. The time period in which the Claim shall be filed with MCSD as set forth in Section 20104.2(a) shall be within twenty (20) days of MCSD's decision, act or omission which gives rise to the Claim, or prior to Final Completion, whichever occurs first.
2. MCSD's 60 day response period set forth in Section 20104.2(c) (1) shall be extended to 90 days from receipt of the Claim.

D. For all Claims submitted by the CONTRACTOR, CONTRACTOR shall include all documentation necessary to substantiate the Claim, which includes, but is not limited to all documentation required to be submitted with the initial Request for Change, pursuant to the General Conditions, Request for Change (Changes At CONTRACTOR's Request), OWNER Initiated Changes and/or Extension of Time for Delay, as applicable, plus any additional documentation or narrative that may have been inadvertently omitted from the initial submission to MCSD and/or ENGINEER, including an explanation as to why said documentation or narrative was not previously included, and any and all documentation, written narratives or other evidence addressing and/or responding to the basis for rejection of the initial Claim including a Request for Change, either in whole or in part, as provided by the ENGINEER and/or MCSD.

E. Pending the final resolution of any Claims arising under, related to or involving this Contract, CONTRACTOR agrees to diligently proceed with the performance of this Contract, including the delivery of goods or providing of services in accordance with MCSD's instructions. CONTRACTOR's failure to diligently proceed in accordance with MCSD's instructions shall be considered a material breach of the Contract.

5.6. DISPUTES

A. For all Claims, including any and all disagreements between the parties as to the merits, amount or remedy arising out of an issue in controversy pertaining to the Project and/or Contract Documents, which remain unresolved after the CONTRACTOR submitted the same to the ENGINEER or MCSD for resolution in accordance with these General Conditions, Claims, the CONTRACTOR shall follow the disputes procedure as provided in Chapter 1 (commencing with Section 900) and Chapter 2 (commencing with Section 910) of Part 3 of Division 3.6 of Title 1 of the Government Code, unless otherwise specified by the Special Provisions. For purposes of those provisions, the running of the period of time within which a dispute must be filed shall be tolled from the time the CONTRACTOR submits its written Claim pursuant to Public Contract Code Section 20104.2(a) and these General Conditions, Claims, until the time that Claim is denied as a result of the meet and confer process, including any period of time utilized by the meet and confer process.

- B. Unless any dispute is made and filed as herein prescribed the dispute shall be forfeited and invalidated and the CONTRACTOR shall not be entitled to any relief, damages, and/or payment in connection therewith.
- C. Pending the final resolution of any dispute arising under, related to or involving this Contract, CONTRACTOR agrees to diligently proceed with the performance of this Contract, including the delivery of goods or providing of services in accordance with MCSD's instructions. CONTRACTOR's failure to diligently proceed in accordance with MCSD's instructions shall be considered a material breach of the Contract.

6. PROSECUTION AND PROGRESS OF THE WORK

6.1. PROGRESS OF THE WORK

The CONTRACTOR shall not commence Work until a Notice to Proceed from MCSD has been received. After receipt of the Notice to Proceed, the CONTRACTOR shall commence Work, and shall thereafter diligently prosecute the same in accordance with the Construction Schedule to complete the Work within the specified time limits of the Contract.

6.2. TEMPORARY SUSPENSION OF WORK

The ENGINEER shall have the authority to suspend the Work wholly or in part, for such period as deemed necessary, due to unsuitable weather, or to such other conditions as are considered unfavorable for the suitable prosecution of the Work, or for such time as deemed necessary due to the failure on the part of the CONTRACTOR to carry out instructions given, or to perform any provision of the Contract. The CONTRACTOR shall immediately comply with the written order of the ENGINEER to suspend the Work wholly or in part. The suspended Work shall be resumed when conditions are favorable and methods are corrected, as ordered by the ENGINEER.

If a suspension of Work is ordered by the ENGINEER due to the failure on the part of the CONTRACTOR to carry out orders given or to perform any provision of the Contract, the CONTRACTOR shall bear all costs associated with the suspension of Work and no extension of time for the completion of the Work shall be granted.

6.3. EXTENSION OF TIME FOR DELAY

If the Work should be delayed at any time by Extra Work or by reason of a suspension ordered by MCSD or because of any other act of MCSD or its officers or employees without contributory fault or neglect on the part of the CONTRACTOR or its agents or employees or its Subcontractors and/or Suppliers or if the Work should be delayed by reason of strikes or abnormal force or violence of the elements or for any other unforeseeable cause beyond the control and without the fault or negligence of the CONTRACTOR, then the CONTRACTOR

may be entitled to an extension of time for completion of the Work equivalent to the time actually lost by such delay.

When any such delays are experienced by the CONTRACTOR and a time extension is requested, the CONTRACTOR shall submit to the ENGINEER, a written time impact analysis illustrating the effects of the change or delay on the current Contract completion date utilizing the Construction Schedule that is current at the time the change or delay is encountered within the time and manner specified herein, and in accordance with Request for Change (Changes At CONTRACTOR's Request) and MCSD Initiated Changes.

The CONTRACTOR shall, within three (3) days from the beginning of any such delay, or within a period of time otherwise agreed upon in writing by the ENGINEER, file a written request with MCSD for extension of time which if initiated by the CONTRACTOR shall be submitted in the form of a Request for Change, as specified herein, Request for Change (Changes At CONTRACTOR's Request) or if the change is initiated by MCSD by the issuance of a Request for Proposal. Failure to do so shall constitute a waiver thereof. Requests for extensions failing to include the information specified in this section or within the time specified above shall result in the forfeiture of the CONTRACTOR's right to receive any extensions of time requested. MCSD will ascertain the facts and the extent of the delay, and its findings of the facts thereon shall be final and conclusive.

Each time impact analysis shall include a Fragnet demonstrating how the CONTRACTOR proposes to incorporate the change or delay into the current Construction Schedule. The Fragnet shall include the sequence of new and/or existing activity revisions that are proposed to be added to the accepted Construction Schedule that is current at the time the change or delay is encountered.

Each time impact analysis shall demonstrate the estimated time impact based on the events of the delay, the anticipated or actual date of the changed Work performance, the status of construction at that point in time, and the event time computation of all activities affected by the change or delay. The event times used in analysis shall be those included in the latest update of the current Construction Schedule in effect at the time the change or delay was encountered. Time extensions will be granted only to the extent that demonstrated time adjustments for the activity or activities affected exceed the total or remaining float along the critical path of activities at the time of actual delay or changed Work performance. Pursuant to the float sharing requirements as described elsewhere in the Contract Documents, time extensions shall not be granted nor delay damages paid until a delay occurs which:

1. Is beyond the control and without the fault or negligence of the CONTRACTOR and its Subcontractors or Suppliers, at any tier; and,
2. Extends actual performance of the Work beyond the current Contract completion date and the most recent date predicted for completion of the Work on the accepted Construction Schedule update that is current as of the time of the delay.

A written request for an extension of time or the granting of an extension of time shall not, in itself, constitute a basis for any Claim against MCSD for additional compensation, or a waiver of MCSD'S right to strictly enforce the time provisions contained in the Contract Documents. Additionally granting of an extension of time shall not in itself constitute a basis for any Claim against MCSD for additional compensation. The CONTRACTOR hereby waives any Claim for additional compensation unless a Claim for additional compensation on account of such delay is filed at the time the request for extension of time is made.

The determination as to whether an extension of time will be granted will be made within sixty (60) days after receipt of a request from the CONTRACTOR as provided above. In the event the CONTRACTOR disagrees with any findings made by MCSD as it concerns adjustment to the period of performance, CONTRACTOR shall proceed with the Claims procedures set forth herein.

No revision to the accepted baseline schedule or updates shall be made without prior written approval from the ENGINEER.

Schedule revisions illustrating the influence of Change Orders and delays shall be incorporated into the Construction Schedule during the first update after agreement is reached.

Any extension of time shall not release the Sureties upon any Bond required under the Contract.

6.4. LABOR COMPETENCY

If any Subcontractor, site superintendent, foreman or person(s) employed by the CONTRACTOR shall fail or refuse to carry out the directions of the ENGINEER or shall appear to the ENGINEER to be incompetent, or to act in a disorderly or improper manner, that person(s) shall be discharged immediately on demand of MCSD and such person(s) shall not again be employed on the Project.

The CONTRACTOR shall bear all costs associated with such discharge of any Subcontractor, site superintendent, foreman or person(s) employed by the CONTRACTOR and such discharge shall not constitute a basis for any Claim against MCSD.

6.5. USE PRIOR TO FINAL COMPLETION (BENEFICIAL OCCUPANCY)

- A. MCSD shall have the right to Beneficially Occupy all or a portion of the Work at no additional cost to MCSD.
- B. If MCSD elects to Beneficially Occupy any completed or partially completed portions of the Work, the ENGINEER shall so document in writing the scope of Work of which it elects to take possession and an inspection shall be made by the CONTRACTOR and ENGINEER of said scope of Work. Based on such inspection, the ENGINEER will attempt to list all incomplete and/or deficient items of Work observed, and provide the CONTRACTOR with such a list. However, the absence of an item from the list shall not relieve the CONTRACTOR of responsibility to perform all of the Work in accordance with

the Contract Documents, and any and all areas so occupied will be subject to Final Inspection after the CONTRACTOR completes all punchlist items, before Final Completion. If such prior use by MCSD delays the progress of the Work or causes additional expense to the CONTRACTOR, the CONTRACTOR shall file a written request for extension of time and/or Extra Work.

- C. Until Final Acceptance of the Work, CONTRACTOR shall guarantee, through the provision and maintenance of sufficient warranties, the following: that the portions of the Work Beneficially Occupied shall perform at all times as part of a fully integrated system consisting of all elements which are being Beneficially Occupied; that the portions of the Work Beneficially Occupied are free from all defects due to faulty materials, equipment or workmanship; and that CONTRACTOR shall promptly make whatever adjustments or corrections which may be necessary to cure any defects, including repairs of any damage to other parts of the system resulting from such defects. MCSD shall promptly give notice to the CONTRACTOR of observed defects. In the event that the CONTRACTOR fails to make adjustments, repairs, corrections or other work made necessary by such defects, MCSD may do so and charge the CONTRACTOR the cost incurred. The CONTRACTOR's warranty shall continue as to any corrected deficiency until the later of (1) the remainder of the original warranty period; or (2) one year after acceptance by MCSD of the corrected work. The Performance Bond and Payment Bond shall each remain in full force and effect through the warranty period.
- D. If MCSD's need to occupy the Work, or any portions thereof, prior to such time as the Work is complete is caused by the CONTRACTOR's failure to complete the Work within the period of performance, including due allowance for extensions of time made in accordance with the Contract Documents, if any, the CONTRACTOR shall bear any and all additional costs associated with completing the Work.

6.6. SUBSTANTIAL COMPLETION

Substantial Completion of the Work means the Work has progressed to the point that MCSD can beneficially occupy or utilize the Work as a whole for the purpose for which it is intended, and the Work complies with applicable codes and regulations, including if required, issuance of certificates of occupancy, or certificate of suitability for use from the appropriate governmental agencies, as determined by the ENGINEER at his/her sole discretion.

When the CONTRACTOR considers that Substantial Completion has been achieved, the CONTRACTOR shall notify the ENGINEER that the Work is substantially complete to the required stage and is ready for inspection and shall include with its Notice of Substantial Completion of the Work a list of minor items, (including the CONTRACTOR's punch list) to be completed or corrected that would not affect Beneficial Occupancy or suitability for use.

After receipt of the CONTRACTOR's Notice of Substantial Completion of Work, the ENGINEER and CONTRACTOR, and any other representative as the ENGINEER deems appropriate, shall make an inspection of the Work to determine whether the Work has been completed in accordance with the Contract Documents and to review the CONTRACTOR's

punch list. If, in the ENGINEER's sole opinion, the Work has not achieved Substantial Completion, the parties shall cease the inspection and all costs incurred by MCSD as a result of the premature inspection shall be deducted from the payments due the CONTRACTOR. CONTRACTOR shall thereafter perform all remaining Work to reach Substantial Completion, and re-submit its Notice of Substantial Completion of Work. The inspection of the Work will re-commence as set forth above. If the Work has achieved Substantial Completion, a punch list shall be prepared by the ENGINEER and consist of those items listed by the CONTRACTOR to be completed or corrected as supplemented by those items observed during the inspection. Failure to include any items on the punchlist shall not alter the responsibility of the CONTRACTOR to complete all Work in accordance with the Contract Documents, nor shall the punch list amend the Contract Documents. All deficiencies and/or items identified on the punch list must be corrected within 30 days of said initial inspection conducted at the Substantial Completion phase, unless otherwise specified in writing by the ENGINEER.

6.7. FINAL COMPLETION AND FINAL ACCEPTANCE

A. Final Inspection

The CONTRACTOR shall notify the ENGINEER in writing when all punch list items have been completed, all Work is completed in accordance with the Contract Documents and all clean-up has been done. Clean-up shall be completed when all waste, materials, excess materials, tools, and equipment such as scaffolding, temporary structures, and unneeded facilities such as fencing and sanitary facilities are removed from the Project. The ENGINEER will then make Final Inspection for the purposes of ascertaining that the Work has been fully completed in accordance with the requirements of the Contract Documents.

B. Final Completion

After the ENGINEER has made the Final Inspection and is satisfied that the Work has been completed in accordance with the Contract Documents, including all punch list items, and is satisfied that all submittals have been made and accepted, including, but not limited to all materials required by the Contract Documents and all As-Builts, Record Drawings by the CONTRACTOR, if required by the Contract, and any other required record documents have been completed and accepted, all Change Order Work has been completed and accepted by the ENGINEER, and all other requirements of the Contract Documents, except for any unexecuted Change Orders, possible future warranty and guarantee Work have been accomplished, the ENGINEER shall certify, in writing, the full completion of the Work and the date thereon.

C. Final Acceptance

The Work, after achieving Final Completion, is subject to Final Acceptance by MCSD. Final Acceptance is defined herein as the "action taken by MCSD accepting the Work as fully completed after certification by the ENGINEER," and occurs in accordance with the following:

CONTRACTOR is required to provide adequate resources to fully support administrative Project close-out efforts identified in the Contract Documents including but not limited to execution of all Change Orders, agreement on all final quantities and all other activities specified herein titled "Final Completion and Final Acceptance," General Conditions section titled "Final Payment." Such support and completion of all administrative close-out activities as required herein must be provided within the timeframe(s) requested by MCSD and is condition precedent to Final Acceptance.

The ENGINEER shall, after certifying the date of Final Completion of the Contract, make a final estimate of the amount of Work done thereunder, and the General Manager or designee shall certify the value of such Work and the date of Final Completion. If the Board finds that the Work has been completed according to the Contract Documents, it shall establish the date of Final Acceptance, and find and declare the Work accepted pursuant to this Section, which shall be evidenced by a Notice of Completion.

A Notice of Completion shall be recorded with the Orange County Clerk Recorder's Office immediately after the Final Acceptance, and in no event later than 10 days from Final Acceptance.

Only upon Final Acceptance shall Final Payment be processed. Processing of Final Payment shall occur in accordance with the provisions herein titled "Final Completion and Final Acceptance." Final Completion and Final Acceptance are for purposes of issuing Final Payment, and neither shall act to relieve the CONTRACTOR from any of its obligations under the Contract Documents, and under no circumstances shall Final Acceptance of the Contract Work waive any rights related to claims by MCSD pertaining to warranties and guarantees, latent defects, indemnity, fraud on the part of the CONTRACTOR, gross mistakes on the part of the CONTRACTOR amounting to fraud, or as otherwise provided in the Contract Documents.

6.8. TIME OF COMPLETION

The CONTRACTOR shall complete all or any designated portion of the Work called for under the Contract in all parts and requirements within the time set forth in the Contract Documents. If, at any time CONTRACTOR's critical path Work progress falls behind schedule, MCSD reserves the right to require the CONTRACTOR to work overtime to bring the Project back on schedule. Such overtime shall be at the CONTRACTOR's expense.

Failure of the CONTRACTOR to perform any covenant or condition contained in the Contract Documents within the time period specified shall constitute a material breach of this Contract entitling MCSD to terminate the CONTRACTOR's performance under the Contract unless the CONTRACTOR applies for, and receives, an extension of time in accordance with the procedures set forth in the section herein entitled Extension of Time for Delay, as well as any and all other remedies available to MCSD by law, in equity or pursuant to the provisions of this Contract.

Failure of MCSD to insist upon the performance of any covenant or condition within the time period specified in the Contract shall not constitute a waiver of the CONTRACTOR's duty to complete performance within the designated period unless the waiver is in writing.

MCSD's agreement to waive a specific time provision or to extend the time for performance shall not constitute a waiver of any other time provisions contained in the Contract Documents. Failure of the CONTRACTOR to complete performance promptly within the additional time authorized in the waiver or extension of time agreement shall constitute a material breach of this Contract entitling MCSD to terminate the CONTRACTOR's performance under the Contract and to any and all other legal or equitable remedies.

The CONTRACTOR shall not be assessed the cost of engineering and inspection during any delay in the completion of the Work caused by acts of God, acts of the public enemy, acts of the public utilities, delays caused by failure of a public agency or owner of a utility to provide for removal or relocation of existing main or trunkline utility facilities or other known utility facilities, fire, floods, earthquake, epidemic, quarantine restrictions, strikes, and unusually severe weather, or delays necessarily resulting from war or national or local emergencies, or delays of Subcontractors due to such causes; provided that the CONTRACTOR shall, within three (3) days from the beginning of any such delay, request an extension of time in accordance with the procedures set forth in this section and as specified in these General Conditions, Extension of Time for Delay. Such delays shall not entitle the CONTRACTOR to any additional compensation. The sole remedy of the CONTRACTOR shall be to seek an extension of time. MCSD shall ascertain the facts and the extent of the delay, and its findings of the facts thereon shall be final and conclusive.

7. PAYMENT FOR WORK

7.1. PAYMENT - GENERAL

Based on written estimates by the ENGINEER or on other evidence satisfactory to the General Manager, MCSD will make monthly progress payments for Work completed. Said progress payments will be based on an approved detailed breakdown of the Contract Price, which shall be furnished by the CONTRACTOR showing unit prices and quantities, as applicable.

Cost of materials will be based on Supplier's invoices. A complete list of invoices shall be presented to the ENGINEER by the CONTRACTOR prior to completion of each estimate. The CONTRACTOR must present to the ENGINEER written evidence substantiating that said purchase price has been paid in full.

Items shown in the detailed breakdown of the Contract Price as unit costs will be included in the progress payments based on the percentage completed for any particular item.

Each progress payment application shall show each Subcontractor and Supplier participating in the Work completed during the previous progress period and the dollar amount of such participation. If the CONTRACTOR disputes a Subcontractor's or Supplier's entitlement to a portion of the previous progress payment, the CONTRACTOR shall submit copies of all

communications between the CONTRACTOR and the Subcontractor explaining the CONTRACTOR's determination not to render payment to such Subcontractor or Supplier. Each progress payment application shall be accompanied by:

1. A conditional waiver and release upon progress payment pursuant to Civil Code Section 8132 for each Subcontractor and Supplier participating in the Work completed during the previous progress period which shall be in an amount no less than the dollar amount of such participation; and
2. A conditional waiver and release upon progress payment pursuant to Civil Code Section 8132 on behalf of the CONTRACTOR which shall be in an amount no less than the dollar amount of the total requested in the payment application.
3. Payment application, which includes a payment certification by the CONTRACTOR certifying that the Work for which payment is requested has been accomplished.

CONTRACTOR shall thereafter, within twenty (20) days of receipt of the payment from MCSD, complete an unconditional waiver and release upon progress payment pursuant to Civil Code Section 8134 for each Subcontractor and Supplier participating in the Work completed during the previous progress period and an unconditional waiver and release upon progress payment pursuant to Civil Code Section 8134 on behalf of the CONTRACTOR in an amount no less than the amount received from MCSD, and submit the same with CONTRACTOR's subsequent payment application.

7.2. PAYMENT – APPLICATIONS FOR PAYMENT

MCSD will not accept payment applications from the CONTRACTOR more frequently than once every four weeks. CONTRACTOR shall submit payment applications to MCSD addressed as follows:

Midway City Sanitary District
14451 Cedarwood Street
Westminster, CA 92863
Attention: Milo Ebrahimi, District Engineer

CONTRACTOR shall include the appropriate Project or Contract Number in the addressee information when submitting applications for payment to the ENGINEER.

Payment terms: net 30 days from receipt of properly submitted payment application.
CONTRACTOR's payment application shall include, at a minimum:

1. Clear reference to MCSD's Project or Contract number, as well as MCSD's Project title, to which the payment application applies.
2. CONTRACTOR's payment application number, payment application date, as well as the Contract payment number the invoice represents; for example, CONTRACTOR's

submittal of its first payment application is payment number 1, its second payment application submittal is payment number 2, and so on. Any CONTRACTOR re-submittal/revision to a submitted payment application shall have a letter suffix (a, b, c, etc.) added to the payment number, signifying the payment application revision; for example, CONTRACTOR's first re-submittal of its first payment application shall be designated as payment for number "1a".

3. Clear reference to the payment schedule item(s) being invoiced and the appropriate milestone description of activities and/or Work related to the billing.
4. The itemized and total amount being invoiced (in U.S. dollars), less the amount of all contractual retention and deductions applicable for the invoiced amount (in U.S. dollars), and the resulting total net payment due.
5. The time period during which the Work was performed and for which the payment application is submitted.
6. Clear reference to the CONTRACTOR's Taxpayer ID Number.

7.3. CONTRACT PRICE ADJUSTMENTS AND PAYMENTS

A. General

1. Basis of Contract Price Adjustment – General

The basis of a Contract Price adjustment for any change to the Contract Documents, consisting of Extra Work, deletion or other revision shall be determined as specified herein.

For all changes to the Contract Documents that result in a Contract Price adjustment, the CONTRACTOR shall submit a cost and schedule proposal in the time and manner specified in the Contract Documents, including General Conditions sections Request for Change (Changes at CONTRACTOR's Request) and MCSD Initiated Changes. The CONTRACTOR's proposal must include a detailed cost breakdown itemizing all costs and schedule impacts associated with the Work, including material, labor, equipment, etc., all necessary back-up documentation to support said estimate, and any other data required by the ENGINEER. Delay by CONTRACTOR in submitting any pricing information required herein or negotiating in good faith with MCSD with regard to costs proposals for Extra Work, deletions or other revisions will result in delays in Contract Price adjustment and/or payment to CONTRACTOR, and MCSD shall not be responsible for any such delays or damages incurred by the CONTRACTOR as a result thereof. Also, the failure of the CONTRACTOR to submit any pricing information required herein or the failure to negotiate in good faith will prevent the Contract Price adjustment and/or payment to the CONTRACTOR, and MCSD shall not be responsible for any such damages incurred by the CONTRACTOR as a result thereof.

Delays in negotiating an adjustment or in providing substantiating documentation may result in the issuance of a unilateral Change Order using MCSD's cost and schedule estimate.

Bilateral Change Order Execution. The execution of a bilateral Change Order is without reservation of right. The execution by MCSD and the CONTRACTOR shall be deemed to be an unconditional agreement to all Extra Work and adjustments to the Contract Price and Contract Duration related to the change.

No adjustments for Extra Work shall be valid unless submitted in writing by the CONTRACTOR and approved in writing by MCSD.

2. Allowable Costs for Extra Work – General

a. Credit Items.

Where the CONTRACTOR or any tier Subcontractor's portion of a change involves credit items or deductive changes, the CONTRACTOR shall utilize the same markups utilized for additive changes in computing the value of the credit. Contract Duration savings/impacts may also be addressed as appropriate to accurately reflect the nature and impact of the credit item or deductive change on the Work.

b. Performance and Payment Bond Costs.

Performance and Payment Bond costs associated with an adjustment shall be limited to the actual increase arising directly out of the Extra Work and will be paid upon receipt of surety premium invoice that is immediately due and payable by the CONTRACTOR. A copy of the Surety's invoice must be provided to document the change in cost of the Bonds.

c. Bid & Proposal Costs.

MCSD does not compensate for Bid preparation or cost and schedule proposal preparation costs.

B. Payment

1. Negotiated Price for Extra Work

a. General

MCSD will issue a Request for Proposal (RFP) requesting a cost and schedule proposal for the Extra Work in accordance with these General Conditions, MCSD Initiated Changes. The CONTRACTOR's substantiated cost and schedule proposal, which shall conform to the requirements herein and the Section herein

entitled MCS D Initiated Changes, must be provided within fifteen (15) days from issuance of a RFP in order to expedite negotiations. Alternatively, if the CONTRACTOR requests the change, the CONTRACTOR will submit a Request for Change which includes its substantiated cost and schedule proposal conforming to the requirements of the Section herein entitled Request for Change (Changes at CONTRACTOR's Request). MCS D may request that the CONTRACTOR certify the cost and schedule proposal. If warranted, MCS D may accept the CONTRACTOR's Bid price for lump sum or unit price amounts in the original or amended form and direct the CONTRACTOR to proceed with the Work. No costs for Extra Work shall be valid unless submitted in writing by the CONTRACTOR and approved in writing by MCS D.

b. Allowable Markup for Extra Work

The allowable markup for Extra Work performed by the CONTRACTOR and/or Subcontractor shall be determined in accordance with the provisions entitled, "Markup" herein, unless otherwise agreed to by MCS D.

2. Price for Extra Work on T&M Basis

When the price for the Extra Work cannot be agreed upon, MCS D may issue a unilateral change using its independent estimate and time impact analysis. MCS D may also direct such Work on a time and materials or force account basis.

Regarding allowable costs MCS D will use those identified above in Section A. MCS D will pay for the Extra Work based on the accumulation of allowable costs as provided herein.

3. Basis for Establishing Costs

a. Labor

The costs of labor will be the actual cost for wages of workers performing the Extra Work at the time the Extra Work is done, plus employer payments of payroll taxes, Worker's Compensation Insurance, liability insurance, health and welfare, pension, vacation, holiday, training, apprenticeship funds, and other direct costs, resulting from federal, state, or local laws, as well as assessments or benefits required by lawful collective bargaining agreements. Payroll taxes shall be calculated on base wage only and not on fringe benefits. Fringe benefits shall be applied only to the straight-time component of cost and shall not apply to the premium-time component unless otherwise required by the California Labor Code.

MCS D will reimburse Worker's Compensation Insurance costs for Extra Work labor at the pure premium rate approved by the California State Insurance Commissioner at the time the Extra Work is completed.

The use of a labor classification that would increase the Extra Work cost will not be permitted unless the CONTRACTOR establishes the necessity for such additional costs. Labor costs for equipment operators and helpers shall be submitted only when such costs are not included in the invoice for equipment rental. The labor cost for foremen shall be proportioned to all of their assigned Work and only that applicable to Extra Work will be paid.

Non-direct labor costs, including management personnel above foreman; office personnel (including clerical and other administrative staff); cost estimating; maintenance mechanics; incidental engineering and all other indirect costs of the Extra Work; and any other costs captured by CONTRACTOR's overhead costs, shall be considered part of markup specified in subsection below, and therefore are not recoverable as direct labor costs, unless the CONTRACTOR can demonstrate both that the costs (1) are not within the CONTRACTOR's overhead costs; and (2) occurred as part of or a direct result of the Extra Work.

Incidental engineering costs, referred to in the preceding paragraph, are considered non-direct labor costs, and include but are not limited to all time spent by engineers for RFI and RFC preparation, Change Order administration, preparation and coordination of shop drawings, attendance at meetings, inspections scheduling, estimating, drawing or manual preparation and revision, Claim preparation, submittal preparation and review, and mix and shoring design.

b. Materials

The cost of materials reported shall be at invoice or lowest current price at which such materials are locally available and delivered to the job site in the quantities involved, plus sales tax, freight, and delivery.

MCSD reserves the right to approve materials and sources of supply, or to supply materials to the CONTRACTOR if necessary for the progress of the Work. No markup shall be applied to any material provided by MCSD.

c. Tools and Equipment

CONTRACTOR-owned equipment charges for Extra Work, or for delays in Work, shall be in accordance with the current State of California, Department of Transportation, Division of Construction of Labor Surcharge and Equipment Rental Rates, as follows:

- i. Working Equipment Rates, 100% of the price listed for the first shift each day and at 50% of that same hourly rate for the second and third shifts each day.
- ii. Standby Equipment Rates, 50% of the price listed.

Tools and equipment rented by the CONTRACTOR will be reimbursed at the actual invoiced amount applicable to the Extra Work. The CONTRACTOR will provide the applicable weekly or monthly rate for tools and/or equipment that will be used in long durations.

No payment will be made for the use of tools or equipment that has a replacement value of \$500 or less.

The reported rental time for equipment already at the worksite shall be the duration of its use on the Extra Work. This time begins when equipment is first put into actual operation on the Extra Work, plus the time required to move it from its previous site and back, or to a closer site.

No payment will be made for use of CONTRACTOR-owned or rented transportation vehicles (including job trucks) unless the vehicle is utilized (1) by personnel at or below the foreman level; and (2) exclusively in connection with performing Extra Work. In such event, the CONTRACTOR will only be entitled to payment for the pro-rata time the vehicle was actually used in connection with the Extra Work, as properly documented and demonstrated by the CONTRACTOR. All other use of CONTRACTOR-owned or rented transportation vehicles shall be considered part of CONTRACTOR's markup specified in subsection below.

d. Other Items

MCSO may authorize other items that may be required on the Extra Work, including labor, services, material, and equipment. These items must be different in their nature from those required for the Work, and be of a type not ordinarily available for the CONTRACTOR or Subcontractors.

Invoices describing all such items in detail shall be submitted with the request for payment.

e. Invoices

Suppliers' invoices for material, equipment rental and other expenditures shall be submitted with the request for payment. If the request for payment is not substantiated by invoices or other documentation, MCSO may establish the cost of the item involved at the lowest price which was current at the time of the report.

f. General Conditions Costs

No increase in the General Conditions costs shall be allowed for Extra Work unless:

- i. such change extends the Contract Duration; or

- ii. CONTRACTOR demonstrates that an increase in actual General Conditions costs were incurred directly and solely as a result of the Extra Work.

4. Markup

a. Work by CONTRACTOR

The following percentages shall be added to the CONTRACTOR’s costs and shall constitute the markup for all overhead and profits:

- i. Labor.....20%
- ii. Materials..... 15%
- iii. Equipment 15%
- iv. Other Items and Expenditures.....15%

b. Work by Subcontractor

Subcontractors performing all or any part of the Extra Work shall apply the same percentages identified in Subsection B.4.a. above, “Work by CONTRACTOR,” which shall be added to the Subcontractor’s costs and shall constitute the markup for all overhead and profits.

MCSD will pay the CONTRACTOR one (1) additional markup of 5% of the Subcontractor’s compensation regardless of the number of intervening tiers of Subcontractors.

c. Contract Unit Prices

MCSD will not pay a markup for units with Unit Prices established in the Contract.

d. Other Costs Not Specifically Designated

The specified markups shall be deemed to include all items of expense not specifically designated and as substantiated as direct cost, indirect cost, or equipment rental in the Labor, Materials, Tools and Equipment, Other Items, and Invoices.

C. Daily Report by CONTRACTOR

When the price for the Extra Work cannot be agreed upon, the CONTRACTOR shall submit a daily report to the ENGINEER on forms approved by the ENGINEER. Included are applicable delivery tickets, listing all labor, materials, and equipment involved for the day, and other services and expenditures when authorized. Failure to submit the daily report by the close of the next working day may waive any rights for that day. An attempt shall be made to reconcile the report daily, and it shall be signed by the ENGINEER and

the CONTRACTOR. In the event of disagreement, pertinent notes shall be entered by each party to explain points that cannot be resolved immediately. Each party shall retain a signed copy of the report. Reports by Subcontractors or others shall be submitted through the CONTRACTOR. MCSD will complete its final review of related costs after receipt of all records, and MCSD reserves its right to correct any errors in said records pertaining to Extra Work, including but not limited to cost found as a result of any such review.

The report shall:

1. Show names of workers, classifications, and hours worked.
2. Describe and list quantities of materials used.
3. Show type of equipment, size, identification number, and hours of operation, including loading, transportation, and stand-by time, if applicable.
4. Describe other services and expenditures in such detail as the ENGINEER may require.

D. Time & Material and Force Account Work

Work performed on a time and materials or force account basis will be subject to a Not to Exceed (NTE) amount. The CONTRACTOR is to provide written notification to the ENGINEER when it has expended seventy-five percent (75%) of the NTE amount. The notification must contain a cost and schedule proposal for the remaining Extra Work or an estimate to complete with an explanation as to why the remaining Extra Work cannot be priced. MCSD may negotiate a fixed price for the remaining Extra Work or if the remaining Extra Work cannot be priced, it may increase the NTE amount. If there is disagreement as to whether the remaining Extra Work can be priced, MCSD may issue a unilateral Change Order based on its independent estimate. In addition to the daily records the CONTRACTOR is required to submit in accordance with Subsection C "Daily Report by CONTRACTOR" above, if a CONTRACTOR seeks additional time arising from the Extra Work, the CONTRACTOR shall also submit all documents supporting any alleged time impacts and associated costs in the time and manner required by General Conditions Section entitled, "Extensions of time for Delay," and in no event later than fifteen (15) days of completion of the Extra Work.

7.4. INCREASE OR DECREASE IN UNIT QUANTITIES

Increases or decreases in the quantity of a Unit (as defined herein as "a single item or group of items constituting a single unit which is identified as a Unit or Unit priced item in the Schedule of Prices"), as identified in the Schedule of Prices, will be determined by comparing, at the time of Final Completion, the actual or measured quantity of the Unit used to complete the Work with the estimated quantity of that Unit shown in the Schedule of Prices. If the actual or measured quantity of a Unit varies more than twenty-five percent (25%) above or below the estimated quantity of the Unit, an adjustment may be made upon demand of either party, and such adjustment will be made in accordance with these General Conditions, "Contract Price Adjustments and Payments." In determining the adjustment to the Contract Price, the CONTRACTOR must, at a minimum, demonstrate its actual price of the Units, supported by

documentation of Supplier/Subcontractor invoiced cost (not including overhead and profit). Said demand shall be made pursuant to these General Conditions, "OWNER Initiated Changes" and/or "Request for Change (Changes at CONTRACTOR's Request)."

The adjustment shall be based upon any increase or decrease in costs due solely to the variations in quantity of the Unit as provided herein. This Section shall not apply to variations in quantity due to a Change Order. Furthermore, when the actual or measured quantity of a Unit required to complete the Work is more than a twenty-five percent (25%) increase from the estimated quantity of the Unit, as shown in the Schedule of Prices, the actual or measured quantity of Units up to one hundred twenty-five percent (125%) of the estimated quantity will be paid at the Contract Unit Price shown in the Schedule of Prices.

If neither party makes a demand for an adjustment in Contract Unit Price for actual or measured quantities above one hundred twenty-five percent (125%) or less than seventy-five percent (75%) of the estimated quantity, MCSD will pay the CONTRACTOR the Contract Unit Price shown in the Schedule of Prices for each such Unit.

7.5. SUSPENSION OF PAYMENTS

If after written notice to the CONTRACTOR of deficiencies in Work, failure to comply with the Contract, failure to comply with the Construction Schedule, or failure to revise and keep current with the Construction Schedule, the ENGINEER shall recommend that all or a portion of payments due or to become due under the Contract be suspended until the CONTRACTOR corrects any such deficiency; the ENGINEER may suspend said payments until such deficiencies are corrected.

7.6. MCSD'S RIGHT TO WITHHOLD CERTAIN AMOUNTS AND MAKE APPLICATION THEREOF

In addition to the amount which MCSD may retain pursuant to the General Conditions, including but not limited to the section entitled Retained Funds, MCSD may withhold a sufficient amount or amounts from any payment otherwise due to the CONTRACTOR as in its judgment may be necessary to cover:

1. Payments which may be past due and payable for properly filed claims against the CONTRACTOR or any Subcontractors for labor or materials furnished in or about the performance of the Work under this Contract.
2. Estimated or actual costs for correcting defective Work not remedied.
3. Amounts claimed by MCSD as forfeiture due to delays or other offsets to the Contract completion caused by the CONTRACTOR.
4. MCSD may contact the CONTRACTOR's Surety and make them aware of the Contract deficiencies, delays and other Contract non-conformance.

MCS D may apply such withheld amount or amounts to the payment of such claims at its discretion. In so doing, MCS D shall be deemed the agent of the CONTRACTOR and any payments so made by MCS D shall be considered as a payment made under the Contract by MCS D to the CONTRACTOR, and MCS D shall not be liable to the CONTRACTOR for such payment made in good faith. Such payments may be made without prior judicial determination of the claim or claims. MCS D will render to the CONTRACTOR a proper accounting of such funds disbursed on behalf of the CONTRACTOR.

7.7. STOP PAYMENT NOTICES

MCS D will, at its option and at any time, retain out of any amounts due the CONTRACTOR, sums sufficient to cover claims plus twenty-five percent (25%) filed pursuant to Section 9350 et. seq. of the Civil Code of the State of California. The CONTRACTOR shall pay to MCS D, or MCS D may deduct from any such payments made by MCS D to the CONTRACTOR, all costs and expenses including but not limited to administrative and legal expenses incurred by MCS D in processing and/or defending against stop payment notices. The CONTRACTOR will use MCS D's current forms for release of stop payment notices.

7.8. AUDIT ACCESS TO RECORDS

- A. The CONTRACTOR shall maintain all books, records, documents, and other evidence directly pertinent to the performance of the Work under this Contract in accordance with generally accepted accounting principles and practices consistently applied, consistent with those principles set forth in Part 31 of Federal Acquisition Regulation, Contract Cost Principles and Procedures. The CONTRACTOR shall also maintain all financial information and data used by the CONTRACTOR in the preparation or support of any cost submissions, including the CONTRACTOR's original Bid, required for this Contract, or any Change Order, Claim or other request for equitable adjustment, and a copy of the cost summary or information submitted to MCS D. MCS D authorized representatives shall have access, upon twenty four (24) hours advanced, written notice at all times during normal business hours, to all such books, records, documents, financial information, and all other evidence for the purpose of inspection, audit, and copying. The CONTRACTOR shall, at no cost to MCS D, provide proper facilities for such access, inspection, and copying purposes. In the event it is determined, by way of an audit or other means, that the CONTRACTOR has been previously overpaid, MCS D shall have the right to deduct any such overpayment from the CONTRACTOR's next progress payment or the Final Payment, or the CONTRACTOR shall within 10 days after receiving notice from MCS D of any such overpayment reimburse MCS D in an amount equal to the overpayment, plus any applicable interest to which MCS D is entitled.

- B. The CONTRACTOR shall maintain cost accounting records, cost and pricing data and any other accounting evidence sufficient to properly reflect all direct and indirect costs of whatever nature pertaining the what CONTRACTOR has incurred, claims to have incurred, or anticipates it will incur in connection with the Contract Work and any and all Change Orders, Requests for Change and/or Claims, including but not limited to:

1. Direct costs of Contract item Work;
 2. Direct costs of changes and/or Extra Work in conformance with the provisions herein entitled Request for Changes (Changes at CONTRACTOR's Request), whether performed by the CONTRACTOR or others;
 3. Direct costs of changes and/or Extra Work in conformance with the provisions herein entitled or OWNER Initiated Changes, whether performed by the CONTRACTOR or others;
 4. Indirect costs of overhead.
- C. The CONTRACTOR agrees to make all items (A) through (H) of this section applicable to this Contract and all Change Orders, Claims, or other requests for equitable adjustments affecting the period of performance or price. The CONTRACTOR agrees to include items (A) through (H) of this section in all of the associated subcontracts and make these items applicable to all subcontracts, at any tier, in excess of \$10,000 and to make items (A) through (H) of this section applicable to all Change Orders, Claims, and other requests for equitable adjustment related to completion of the Work.
- D. Audits conducted under this Section shall be in accordance with generally accepted auditing standards and established procedures and guidelines of the reviewing or audit agency.
- E. The CONTRACTOR agrees to the disclosure of all information and reports resulting from access to records under items (A) through (H) of this section, to MCSD and other affected agencies.
- F. Records under Items (A) through (H) of the Section shall be maintained and made available during the performance of the Work under this Contract until 3 years past Final Payment, and until final settlement of all disputes, Claims, or litigation, whichever occurs later. In addition, those records which relate to any portion of this Contract, to any Change Order, to any dispute, to any litigation, to the settlement of any Claims arising out of such performance, or to costs or items to which an audit exception has been taken, shall be maintained and made available until Final Payment or final resolution of such dispute, litigation, Claim, or exception, whichever occurs later.
- G. This right of access article applies to all financial records pertaining to the Contract and all Change Orders. In addition, this right of access applies to all records pertaining to all contracts, Change Orders, and Contract amendments:
1. To the extent the records pertain directly to Contract performance;
 2. If there is any indication that fraud, gross abuse, or corrupt practices may be involved;
or

3. If the CONTRACTOR's performance under the Contract is terminated for default or convenience.

H. Access to records is not limited to the required retention periods. The authorized representatives of MCSD shall have access to records at any reasonable time for as long as the records are maintained.

7.9. RETAINED FUNDS; SUBSTITUTION OF SECURITIES

From each progress payment MCSD shall retain five percent (5%) of the funds due the CONTRACTOR to assure satisfactory completion of the Contract. The cumulative amount retained as retention amounts shall be retained by MCSD until the Final Payment, and shall not exceed 5% of the Contract Price as amended or adjusted by Change Orders.

To ensure performance under the Contract Documents, the CONTRACTOR may, at its sole expense, substitute securities equivalent to the retention withheld by MCSD. Such securities shall be deposited with an escrow agent approved by MCSD, who shall then pay such retention to the CONTRACTOR. Upon satisfactory completion of the Work, the securities shall be returned to the CONTRACTOR. The CONTRACTOR shall be the beneficial owner of any security substituted for monies withheld and shall receive any accrued interest thereon. Securities eligible for investment shall include those listed in Government Code § 16430, bank or savings and loan certificates of deposit, interest bearing demand deposit accounts, standby letters of credit, or any other security mutually agreed to by the CONTRACTOR and MCSD. No such substitution shall be accepted until the escrow agreement, securities, and any other documents related to the substitution are executed by the CONTRACTOR and reviewed and accepted in writing by MCSD.

7.10. FINAL PAYMENT

CONTRACTOR shall, prior to Final Acceptance, prepare and submit an application for Final Payment to MCSD, in a form and manner approved by the ENGINEER.

The Final Payment including retention shall not be due and payable until after Final Acceptance occurs as more particularly set forth in Section "Final Completion and Final Acceptance" herein, MCSD'S receipt of all documentation, records, and releases as required by the Contract and executed by the CONTRACTOR, and the expiration of thirty-five (35) days from the date of the recordation of Notice of Completion by MCSD.

If the CONTRACTOR fails to complete the Work as specified in the Contract Documents and if the unpaid balance of the Contract Price exceeds the direct and indirect costs of completing the Project, including, but not limited to, all costs generated to insure or bond the Work of substituted contractors or Subcontractors utilized to complete the Work, such excess shall be paid to CONTRACTOR. If such costs exceed the unpaid balance, CONTRACTOR shall pay the difference to MCSD promptly upon demand. On failure of CONTRACTOR to pay, the Surety shall pay on demand by MCSD. Any portion of such difference not paid by

CONTRACTOR or Surety within thirty (30) days following the mailing of a demand for such costs by MCSD shall earn interest at the maximum rate authorized by California law.

It is mutually agreed between the parties to the Contract that no certificate given or payment made, under the Contract, shall be conclusive evidence of performance of the Contract, and no payment shall be construed to be an acceptance of any defective Work or improper materials.

The CONTRACTOR further agrees that the payment of the final amount due, under the Contract, and the adjustments and payments for any Work done in accordance with any alterations of the same, shall release MCSD, the Board of Directors and the CONSULTANT, and each of their directors, officers, employees, and agents, from any and all claims or liability on account of Work performed under the Contract or any alteration thereof.

8. MISCELLANEOUS

8.1. GOVERNING LAW

The Contract Documents have been negotiated between MCSD and the CONTRACTOR and shall be subject to and interpreted under the laws of the State of California.

By entering into the Contract, the CONTRACTOR consents and submits to the jurisdiction of the Courts of the State of California, County of Orange, over any action at law, suit in equity, and/or other proceeding that may arise out of the Contract Documents.

Paulus Engineering, Inc.

2871 E. Coronado St.
Anaheim, CA 92806
Phone: (714) 632-3975
Fax: (714) 632-5077

Request for Change Order

To: Midway City Sanitation Dist.
14451 Cedarwood Ave.
Westminster, CA 92683
Project: Emergency Sewer Main Repair

RFC No: 1229-01
Date: 5/14/2024
Description: Paulus Engineering requests a change order for the amount below for Additional Work to cover pumping groundwater from the excavation and disposing at the approved OCSD site. Cost does not include any dumping fees.

The above work is subject to the same conditions as specified in the original contract unless otherwise stipulated.

Upon approval the sum of \$7,475.00 will be added to the contract price.

Original Contract	\$103,231.00
Other Approved Change Orders	\$0.00
Total Contract to Date	\$103,231.00
This Request	\$7,475.00
Other Pending Requests	\$0.00
Total Contract plus Pending RFCs	\$110,706.00

Authorized Signature:  Date: 5-14-24
Paulus Engineering, Inc.

Authorized Signature:  Date: 5.14.24
Midway City Sanitation Dist.

AGREEMENT FOR EMERGENCY SEWER LINING REPAIRS

*Performance Pipeline Technologies, Inc.
(Emergency CIPP Lining of Sewer Mains in Webber Place and Pembroke Lane)*

THIS AGREEMENT FOR EMERGENCY SEWER LINING REPAIRS (hereinafter “Agreement” or “Contract”) is made this 21st day of May, 2024, by the MIDWAY CITY SANITARY DISTRICT, a public entity (hereinafter referred to as ”DISTRICT”) and PERFORMANCE PIPELINE TECHNOLOGIES, INC., a California corporation, (hereinafter referred to as “CONTRACTOR”). DISTRICT and CONTRACTOR are sometimes hereinafter individually referred to as “Party” and are hereinafter collectively referred to as the “Parties.”

RECITALS

The following recitals are a substantive part of this Agreement:

- A. This Agreement is entered into pursuant to authorization of the Midway City Sanitary District Board of Directors, dated May 21, 2024, and Public Contract Code Sections 20806 and 22050.
- B. DISTRICT has determined there is a need to retain the services of a qualified contractor to perform emergency sewer lining repairs consisting of cured-in-place pipe (CIPP) installation within the sewers in Webber Place between Manhole 2006 and Manhole 2005 and in Pembroke Lane between Manhole 2006 and Manhole 2019 (the “Project”).(the “Project”).
- C. CONTRACTOR has submitted to DISTRICT a proposal, dated May 14, 2024, to complete the PROJECT (the “Proposal”).
- D. CONTRACTOR represents and maintains that it is ready, willing, and able to perform the emergency sewer repairs required as specified in Sections 1 and 2 of this Agreement and in accordance with the terms and conditions of this Agreement and under the direction of the District’s Engineer.
- E. DISTRICT desires to retain CONTRACTOR to complete the Project.

AGREEMENT

THE PARTIES MUTUALLY AGREE AS FOLLOWS:

1. Scope of Work and General Conditions.

1.1 Scope of Work. In compliance with all terms and conditions of this Agreement, CONTRACTOR shall furnish, under the conditions expressed in the Plans and Specifications, at its own expense, all tools, equipment, materials and supplies and shall perform all labor necessary to complete the Project in good workmanlike and substantial order (hereinafter referred to as the

“Scope of Work,” the “Services” or “Work”). “Project” shall mean the work to be performed under the “Contract Documents,” as defined below. All Work or Services shall be completed to the reasonable satisfaction of DISTRICT.

1.2 Contract Documents. The Agreement between the Parties shall consist of the “Contract Documents,” which shall consist of following: (1) this Agreement (also referred to as the “Contract”); (2) CONTRACTOR’S Proposal attached hereto at Exhibit A; (3) the Plans and Specifications attached hereto at Exhibit B; and (4) the General Conditions attached hereto at Exhibit C. Each of the Contract Documents is hereby incorporated by reference into this Agreement with the same force and effect as if the same were set forth at length herein. All provisions of the Contract Documents shall be binding on the Parties. Should any conflict or inconsistency exist in the Contract Documents, the conflict or inconsistency shall be resolved by applying the provisions in the highest priority document, which shall be determined in the following order of priority: (1st) the terms and conditions of this Agreement; (2nd) the terms and provisions of the Plans and Specifications (Exhibit B); (3rd) the terms and provisions of the General Conditions (Exhibit C); and (4th) the provisions of the CONTRACTOR’s Proposal (Exhibit A).

1.3 Compliance with Law. CONTRACTOR shall comply at all times during the term of this Agreement with all applicable laws, ordinances, codes, and regulations of the federal, state, and local government, including without limitation all applicable fair labor standards and Cal/OSHA requirements. CONTRACTOR shall keep itself fully informed of and in compliance with all local, state, and federal laws, rules, and regulations in any manner affecting the performance of the Work and Services, including all Cal/OSHA requirements, and shall give all notices required by law. CONTRACTOR shall be liable for all violations of such laws and regulations in connection with performing the Work and Services. If CONTRACTOR performs any Work or Services in violation of such laws, rules, and regulations, CONTRACTOR shall be solely responsible for all penalties and costs arising therefrom. CONTRACTOR shall defend, indemnify, and hold DISTRICT, its officials, officers, employees, agents and volunteers, free and harmless from any claim or liability arising out of any failure or alleged failure to comply with such laws, rules, or regulations.

1.4 Licenses, Permits, and Fees. Prior to performing any Services or Work hereunder CONTRACTOR shall obtain all licenses, permits, qualifications, and approvals of whatever nature that are legally required to practice its profession and perform the Work and Services required by this Agreement. CONTRACTOR represents and warrants to DISTRICT that CONTRACTOR shall, at its sole cost and expense, keep in effect at all times during the term of this Agreement and any extension, any license, permit, qualification, or approval that is legally required for CONTRACTOR to perform the Work and Services under this Agreement. CONTRACTOR further represents and warrants to DISTRICT that CONTRACTOR is in good standing and authorized to do business in California and the local jurisdiction(s) comprising the site for the Work and is properly registered with the California Secretary of State pursuant to applicable law. CONTRACTOR shall have the sole obligation to pay for any fees, assessments, and taxes, plus applicable penalties and interest, which may be imposed by law and arise from or are necessary for the CONTRACTOR’s performance of the Work and Services required by this Agreement, and shall defend, indemnify, and hold DISTRICT, its officials, officers, employees, agents and

volunteers, free and harmless from and against any claim or liability arising out of any failure or alleged failure to obtain such license, permits, and approvals of whatever nature that are legally required to perform the Work or Services.

1.5 Familiarity with Work. By executing this Agreement, CONTRACTOR warrants that: (1) it is fully familiar with all the terms, conditions, and obligations of the Contract Documents; (2) it has thoroughly investigated and considered the Scope of Work or Services to be performed; (3) it has carefully considered how the Services or Work should be performed and has carefully examined the location or locations at or with respect to where such Services or Work is to be performed and is aware of all conditions there; and (4) it understands the facilities, difficulties, and restrictions of attending performance of the Services or Work under this Agreement. If the Services or Work involve work upon any site, CONTRACTOR represents and maintains that CONTRACTOR has or will investigate the site and is or will be fully acquainted with the conditions there existing, prior to commencement of any Services or Work hereunder. Should CONTRACTOR discover any latent or unknown conditions materially differing from those inherent in the Work or as represented by DISTRICT, it shall immediately inform DISTRICT of this and shall not proceed, except at CONTRACTOR's risk, until written instructions are received from DISTRICT.

1.6 Care of Work. CONTRACTOR shall adopt reasonable methods during the term of the Agreement to furnish continuous protection to the Work and the equipment, materials, papers, documents, plans, studies, and/or other components thereof to prevent losses or damages, and shall be responsible for all such damages, to persons or property, until acceptance of the Work by DISTRICT, except such losses or damages as may be caused by DISTRICT's own negligence.

1.7 Stop Notices. In the event DISTRICT receives a stop notice from any laborer or material supplier alleging non-payment by CONTRACTOR, DISTRICT shall be entitled to deduct all of its costs and expenses incurred relating thereto, including but not limited to administrative and legal fees.

1.8 Further Responsibilities of Parties. Both Parties agree to use reasonable care and diligence to perform their respective obligations under this Agreement. Both Parties agree to act in good faith to execute all instruments, prepare all documents, and take all actions as may be reasonably necessary to carry out the purposes of this Agreement.

2. Time of Commencement and Completion.

2.1 Schedule of Performance. The time of commencement and completion of the Project ("Schedule of Performance") shall be as mutually agreed to in writing by the CONTRACTOR and DISTRICT's Engineer.

2.2 Time of Essence. Time is of the essence in the performance of this Agreement. The time for commencement and completion of the Work to be performed by CONTRACTOR is an essential condition of this Agreement. CONTRACTOR shall prosecute regularly and diligently the Work according to the agreed upon Schedule of Performance.

3. Contract Price and Method of Payment.

3.1 Contract Price. DISTRICT agrees to pay and CONTRACTOR agrees to accept as full consideration for the faithful performance of this Agreement, subject to any subsequent additions or deductions as provided in approved change orders, the lump sum of THIRTY NINE THOUSAND SEVEN HUNDRED SIXTY DOLLARS and 00/100 CENTS (\$39,760.00), as itemized on CONTRACTOR's Proposal (Exhibit A) (the "Contract Price"). The Contract Price shall include the attendance of CONTRACTOR at all Project meetings deemed reasonably necessary by the DISTRICT. CONTRACTOR shall not be entitled to any increase in the Contract Price for attending these meetings. In addition to payment of the Contract Price, DISTRICT agrees to reimburse CONTRACTOR for the actual cost of any bonds, permits, and/or other items specified in CONTRACTOR's Proposal as excluded from the Contract Price.

3.2 Payment. Prior to the twentieth (20th) day of the month next following the commencement of the Work, there shall be paid to CONTRACTOR a sum equal to ninety-five percent (95%) of the value of the actual Work completed as determined by DISTRICT; and thereafter, prior to the twentieth (20th) day of each successive month as the work progresses, CONTRACTOR shall be paid such sum as will bring the total payments received, since the commencement of the Work as determined by the DISTRICT (less all previous payments) to ninety-five percent (95%) of the value of the actual Work completed, provided that CONTRACTOR submits its request for payment prior to the last day of the preceding month. Partial payments on the Contract Price shall not be considered as an acceptance of any part of the Work. Pursuant to Public Contract Code Section 22300, CONTRACTOR will be permitted to substitute securities for any monies withheld by DISTRICT to ensure performance of the Agreement.

3.3 Changes in Contract Price. Any changes to the Contract Price shall be pursuant to written change order approved by the DISTRICT as set forth in the General Conditions (Exhibit C).

3.4 Termination. If termination of this Agreement for default or convenience is effected by the DISTRICT in accordance with paragraphs (a) or (b) of Section 11, an equitable adjustment in the Contract Price shall be made, but (1) no amount shall be allowed for anticipated profit on unperformed services or other work, and (2) any payment due to the CONTRACTOR at the time of termination may be adjusted to cover any additional costs to the DISTRICT because of the CONTRACTOR's default. If termination for default is effected by the CONTRACTOR in accordance with paragraph (a) of Section 11, the equitable adjustment shall include a reasonable profit for services or other work performed, but no adjustment will be allowed for anticipated profits. The equitable adjustment for any termination shall provide for payment to the CONTRACTOR for services rendered and expenses incurred prior to the termination, in addition to termination settlement costs reasonably incurred by the CONTRACTOR relating to commitments which had become firm prior to the termination.

4. Completion. Within ten (10) days after the completion date of the Project, CONTRACTOR shall file with the DISTRICT's Engineer its affidavit stating that all workers and persons have been paid in full, and that there are no claims outstanding against the Project for

either labor or material, except those certain items, if any, to be set forth in affidavit covering disputed claims, or items in connection with Stop Notices which have been filed under the provisions of the statutes of the State of California. DISTRICT may require affidavits or certificates of payment and/or releases from any subcontractor, laborer or material supplier.

5. Warranty.

(a) CONTRACTOR agrees to perform all Work under this Agreement in accordance with the Plans and Specifications.

(b) CONTRACTOR guarantees for a period of at least one (1) year from the date of completion of the Work that the completed work is free from all defects due to faulty materials, equipment or workmanship and that it shall promptly make whatever adjustments or corrections may be necessary to cure any defects, including repairs of any damage to other parts of the Project resulting from such defects. DISTRICT shall promptly give notice to CONTRACTOR of observed defects. In the event that CONTRACTOR fails to make adjustments, repairs, corrections or undertake other work made necessary by such defects, DISTRICT may do so and charge CONTRACTOR the cost incurred. The Performance Bond shall remain in full force and effect through the guarantee period.

(c) CONTRACTOR's obligations under this clause are in addition to CONTRACTOR's other express or implied assurances under this Agreement or state law and in no way diminish any other faulty materials, equipment or work.

6. Prevailing wages. DISTRICT has determined that the Work and Services under this Agreement requires work of labor categories which are subject to Prevailing Wage Laws identified in the State of California Labor Code. CONTRACTOR is aware of the requirements of California Labor Code Section 1720, et seq., and 1770, et seq., as well as California Code of Regulations, Title 8, Section 16000, et seq., ("Prevailing Wage Laws"), which require the payment of prevailing wage rates and the performance of other requirements on "public works" and "maintenance" projects. CONTRACTOR agrees to fully comply with all applicable federal and state labor laws (including, without limitation, the Prevailing Wage Laws). It is agreed by the Parties that, in connection with the Work or Services provided pursuant to this Agreement, CONTRACTOR shall bear all risks of payment or non-payment of prevailing wages under California law, and Consultant hereby agrees to defend, indemnify, and hold DISTRICT, its elected officials, officers, employees, and agents free and harmless from any claim or liability arising out of any failure or alleged failure to comply with the Prevailing Wage Laws. The foregoing indemnity shall survive termination of this Agreement CONTRACTOR understands and agrees to comply with the following California Labor Code compliance conditions [Labor Code Sections 1720 et seq., 1813, 1860, 1861, 3700]:

(a) This Agreement is subject to the provisions of Division 2, Part 7, Chapter 1 (commencing with Section 1720) of the California Labor Code relating to public works and the awarding public agency ("DISTRICT") and CONTRACTOR agrees to be bound by all the provisions thereof as though set forth in full herein.

(b) CONTRACTOR shall be registered with the Department of Industrial Relations (“DIR”) in accordance with California Labor Code Section 1725.5 and has provided proof of registration to DISTRICT prior to the Effective Date of this Agreement.

(c) CONTRACTOR agrees to comply with the provisions of California Labor Code Sections 1771, 1774 and 1775 concerning the payment of prevailing rates of wages to workers and the penalties for failure to pay prevailing wages. The applicable prevailing wage determination(s) may be obtained at <https://www.dir.ca.gov/oprl/dprewagedetermination.htm>, are on file with DISTRICT, and are available to any interested party upon request. A copy of said rates shall be posted at each job site during the Term of this Agreement.

(d) Pursuant to California Labor Code Section 1771.4, CONTRACTOR’s services are subject to compliance monitoring and enforcement by the Department of Industrial Relations. CONTRACTOR shall post job site notices as prescribed by DIR regulations and furnish the records specified in California Labor Code Section 1776 directly to the Labor Commissioner in the manner prescribed by California Labor Code Section 1771.4(a)(3) and (c)(2).

(e) CONTRACTOR shall comply with the provisions of California Labor Code Section 1776 which, among other things, require Contractor and each subcontractor to (1) keep accurate payroll records, (2) certify and make such payroll records available for inspection as provided by Section 1776, and (3) inform the DISTRICT of the location of the records. CONTRACTOR is responsible for compliance with Section 1776 by itself and all of its subcontractors.

(f) CONTRACTOR shall comply with the provisions of California Labor Code Section 1777.5 concerning the employment of apprentices on public works projects, and further agrees that CONTRACTOR is responsible for compliance with Section 1777.5 by itself and all of its subcontractors.

(g) Eight (8) hours of labor shall constitute a legal day’s work for all workmen employed in the execution of this Agreement, and CONTRACTOR and any subcontractor shall comply with and be governed by the laws of the State of California having to do with working hours set forth in Division 2, Part 7, Chapter 1, Article 3 of the California Labor Code. CONTRACTOR shall comply with the provisions of California Labor Code Section 1813 concerning penalties for workers who work excess hours. CONTRACTOR shall, as a penalty to DISTRICT, forfeit twenty-five dollars (\$25) for each worker employed in the execution of this Agreement by the CONTRACTOR or by any subcontractor for each calendar day during which such worker is required or permitted to work more than eight (8) hours in any one calendar day and forty (40) hours in any one calendar week in violation of the provisions of Division 2, Part 7, Chapter 1, Article 3 of the California Labor Code. (See, e.g., Cal. Labor Code §1815.)

(h) Pursuant to California Labor Code Sections 1860 and 3700, CONTRACTOR will be required to secure the payment of compensation to its employees. By signing this Agreement, CONTRACTOR hereby certifies as follows:

“I am aware of the provisions of Section 3700 of the Labor Code which require every employer to be insured against liability for workers’ compensation or to undertake self-insurance in accordance with the provisions of that code, and I will comply with such provisions before commencing the performance of the work of this Agreement.”

(i) Pursuant to California Labor Code Section 1771.1, CONTRACTOR and any subcontractor shall not be qualified to bid on, be listed in a bid proposal, subject to the requirements of Section 4104 of the California Public Contract Code, or engage in the performance of any contract for public work on a public works project unless registered with the DIR and qualified to perform public work pursuant to California Labor Code Section 1725.2. It is not a violation of California Labor Code Section 1771.1 for an unregistered contractor to submit a bid that is authorized by California Business and Professions Code Section 7029.1 or by California Public Contract Code Section 10164 or 20103.5, provided the contractor is registered to perform public work pursuant to Section 1725.5 at the time the contract is awarded. CONTRACTOR shall not perform any work under this Agreement with any subcontractor who is ineligible to perform work on the public works project pursuant to Section 1777.1 or 1777.7 of the California Labor Code. By submitting a bid or proposal to DISTRICT, CONTRACTOR is certifying that it has verified that all subcontractors used on this public work project are registered with the DIR in compliance with Labor Code sections 1771.1 and 1725.5, and CONTRACTOR shall provide proof of registration for themselves and all listed subcontractors to DISTRICT upon request.

(j) CONTRACTOR shall provide the list of subcontractors, along with their DIR registration numbers, utilized on this Agreement prior to any Work being performed; and the CONTRACTOR shall provide a complete list of all subcontractors with each invoice. Additionally, CONTRACTOR shall provide DISTRICT with a complete list of all subcontractors utilized on this Agreement within ten working days of the completion of the Work, along with their DIR registration numbers.

7. Limitations Upon Subcontracting and Assignment.

7.1 Subcontracting. Except for those entities disclosed in CONTRACTOR’s Proposal or subsequently approved by the DISTRICT in writing, CONTRACTOR shall not contract with any other entity to perform any portion of the Work without written approval of the DISTRICT. If CONTRACTOR is permitted to subcontract any part of this Agreement, each such subcontractor shall be duly licensed and registered, and CONTRACTOR shall be responsible to DISTRICT for the acts and omissions of its subcontractor as it is for persons directly employed. Nothing contained in this Agreement shall create any contractual relationship between any subcontractor and DISTRICT. All persons engaged in the work will be considered employees of CONTRACTOR. DISTRICT will deal directly with and will make all payments to CONTRACTOR. CONTRACTOR represents and warrants that it has complied, and will comply, with all applicable provisions the Subletting and Subcontracting Fair Practices Act, Public Contract Code Sections 4100 through 4113, inclusive.

7.2 **Assignment.** No assignment(s) by the CONTRACTOR of this Agreement or any part hereof, or of funds to be received hereunder, will be recognized by the DISTRICT unless such assignment(s) has(have) had prior written approval and consent of the DISTRICT and the surety.

8. **Surety Bonds.** If the Contract Price is in excess of \$25,000.00, CONTRACTOR shall, before entering upon the performance of this Agreement, furnish bonds approved by the DISTRICT's General Counsel - one in the amount of one hundred percent (100%) of the Contract Price bid, to guarantee the faithful performance of the work and one year guarantee, and the other in the amount of one hundred percent (100%) of the Contract Price bid to guarantee payment of all claims for labor and materials furnished. This Agreement shall not become effective until such bonds are supplied to and approved by the DISTRICT.

9. **Insurance requirements.**

9.1 **Commencement of Work.** CONTRACTOR shall not commence work under this Agreement until all certificates and endorsements have been received and approved by the DISTRICT. All insurance required by this Agreement shall contain a Statement of Obligation on the part of the carrier to notify the DISTRICT of any material change, cancellation, or termination at least thirty (30) days in advance.

9.2 **Workers Compensation Insurance.** During the duration of this Agreement, CONTRACTOR and all subcontractors shall maintain Workers Compensation Insurance in the amount and type required by law, if applicable.

9.3 **Insurance Amounts.** CONTRACTOR and all subcontractors shall procure and maintain insurance acceptable to DISTRICT. Unless otherwise agreed or waived in writing by DISTRICT's General Manager, CONTRACTOR and all subcontractors shall maintain the following insurance for the duration of this Agreement:

(a) Commercial general liability in an amount of \$5,000,000.00 per occurrence: **claims made and modified occurrence policies are not acceptable**; Insurance companies must be acceptable to DISTRICT and have a Best's Guide Rating of A- Class VII or better, as approved by the DISTRICT.

(b) Automobile liability in an amount of \$1,000,000.00 combined single limit: **claims made and modified occurrence policies are not acceptable**; Insurance companies must be acceptable to DISTRICT and have a Best's Guide Rating of A- Class VII or better, as approved by the DISTRICT.

An **On-Going and Completed Operations Additional Insured Endorsement** for the policy under section 4.3 (a) shall designate DISTRICT, its officers, officials, employees, agents, and volunteers as additional insureds for liability arising out of work or operations performed by or on behalf of the CONTRACTOR. CONTRACTOR shall provide to DISTRICT proof of insurance and endorsement forms that conform to DISTRICT's requirements, as approved by the DISTRICT.

An Additional Insured Endorsement for the policy under section 4.3 (b) shall designate DISTRICT, its officers, officials, employees, agents, and volunteers as additional insureds for automobiles, owned, leased, hired, or borrowed by the CONTRACTOR. CONTRACTOR shall provide to DISTRICT proof of insurance and endorsement forms that conform to DISTRICT's requirements, as approved by the DISTRICT.

For any claims related to this Agreement, CONTRACTOR's insurance coverage shall be primary insurance as respect to DISTRICT, its officers, officials, employees, agents, and volunteers. Any insurance or self-insurance maintained by the DISTRICT, its officers, officials, employees, agents, and volunteers shall be excess of the CONTRACTOR's insurance and shall not contribute with it.

If CONTRACTOR maintains higher insurance limits than the minimums shown above, CONTRACTOR shall provide coverage for the higher insurance limits otherwise maintained by the CONTRACTOR.

10. Risk and Indemnification. All work covered by this Agreement done at the Project site or in preparing or delivering materials to the site shall be at the risk of CONTRACTOR alone. CONTRACTOR agrees to save, indemnify and keep DISTRICT, its officers, officials, employees, agents, architects, engineers, and consultants for this Agreement, and all public agencies from whom permits will be obtained, harmless against any and all liability, claims, judgments, costs and demands, including demands arising from injuries or death of persons (CONTRACTOR's employees included) and damage to property, arising directly or indirectly out of the obligations herein undertaken or out of the operations conducted by CONTRACTOR, save and except claims or litigation arising through the active negligence or willful misconduct of DISTRICT, and CONTRACTOR will make good to and reimburse, DISTRICT for any expenditures, including reasonable attorney's fees DISTRICT may incur by reason of such matters, and if requested by DISTRICT, will defend any such suits at the sole cost and expense of CONTRACTOR. This hold harmless agreement shall apply to all liability regardless of whether any insurance policies are applicable. The policy limits do not act as a limitation upon the amount of indemnification to be provided by CONTRACTOR.

11. Termination.

(a) This Agreement may be terminated in whole or in part in writing by either party in the event of substantial failure by the other party to fulfill its obligations under this Agreement through no fault of the terminating party, provided that no termination may be effected unless the other party is given: (1) not less than ten (10) calendar days' written notice (delivered by certified mail, return receipt requested) of intent to terminate, and (2) an opportunity for consultation with the terminating party prior to termination.

(b) This Agreement may be terminated in whole or in part in writing by the DISTRICT for its convenience, provided that the CONTRACTOR is given (1) not less than ten (10) calendar days' notice (delivered by certified mail, return receipt requested) or intent to terminate, and (2) an opportunity for consultation with the DISTRICT prior to termination.

(c) Upon receipt of termination action under paragraph (a) or (b) above, the CONTRACTOR shall (1) promptly discontinue all affected work (unless the notice directs otherwise), and (2) deliver or otherwise make available to the DISTRICT all data, drawings, specifications, reports, estimates, summaries and such other information and materials as may have been accumulated by the CONTRACTOR in performing this Agreement whether completed or in process.

(d) Upon termination under paragraphs (a) or (b) above, the DISTRICT may take over the work and may award another party an agreement to complete the work under this Agreement.

12. Non-Liability of Officials and Employees of the District. No official or employee of DISTRICT shall be personally liable to CONTRACTOR in the event of any default or breach by DISTRICT, or for any amount which may become due to CONTRACTOR.

13. Conflict of Interest. No officer or employee of the DISTRICT shall have any financial interest, direct or indirect, in this Agreement nor shall any such officer or employee participate in any decision relating to the Agreement which effects his or her financial interest or the financial interest of any corporation, partnership, or association in which they are, directly or indirectly, interested in violation of any state statute or regulation. CONTRACTOR represents and warrants that it has not paid or given and will not pay or give any third party any money or other consideration in exchange for obtaining this Agreement.

14. Covenant Against Discrimination. In connection with its performance under this Agreement, CONTRACTOR shall not discriminate against any employee or applicant for employment because of race, disability, medical condition, religion, color, sex, sexual orientation, age, marital status, ancestry, or national origin. CONTRACTOR shall ensure that applicants are employed, and that employees are treated during their employment, without regard to their race, disability, medical condition, religion, color, sex, sexual orientation, age, marital status, ancestry, or national origin. Such actions shall include, but not be limited to, the following: employment, upgrading, demotion or transfer; recruitment or recruitment advertising; layoff or termination; rates of pay or other forms of compensation; and selection for training, including apprenticeship.

15. Independent Contractor. The legal relationship between the Parties is that of an independent contractor, and nothing herein shall be deemed to make CONTRACTOR a DISTRICT employee.

16. Notices. All notices shall be personally delivered or mailed to the below listed address, or to such other addresses as may be designated by written notice, and shall be deemed received upon the earlier of (i) the date of delivery to the address of the person to receive such notice if delivered personally or by messenger or overnight courier; or (ii) five (5) business days after the date of posting by the United States Post Office if by mail. These addresses shall be used for delivery of service of process.

(CONTRACTOR) Performance Pipeline Technologies, Inc.
Attention: Gene Glassburner
5292 System Drive
Huntington Beach, CA 92649

(DISTRICT) Midway City Sanitary District
Attention: District Engineer
14451 Cedarwood Street
Westminster, CA 92863

(WITH COPY TO) Midway City Sanitary District
Attention: General Counsel
14451 Cedarwood Street
Westminster, CA 92863

17. Reports.

(a) Each and every report, draft, work product, map, video, record and other document, hereinafter collectively referred to as "Report", reproduced, prepared or caused to be prepared by CONTRACTOR pursuant to or in connection with this Agreement, shall be the exclusive property of DISTRICT. CONTRACTOR shall not copyright any Report required by this Agreement and shall execute appropriate documents to assign to District the copyright to Reports created pursuant to this Agreement. Any Report, information and data acquired or required by this Agreement shall become the property of DISTRICT, and all publication rights are reserved to DISTRICT.

(b) All Reports prepared by CONTRACTOR may be used by DISTRICT in execution or implementation of:

- (1) The original Project for which CONTRACTOR was hired;
- (2) Completion of the original Project by others;
- (3) Subsequent additions to the original Project; and/or
- (4) Other DISTRICT projects as appropriate.

(c) No Report, information or other data given to or prepared or assembled by CONTRACTOR pursuant to this Agreement shall be made available to any individual or firm by CONTRACTOR without prior approval by District.

18. Waiver. No waiver of any provision of this Agreement shall be effective unless in writing and signed by a duly authorized representative of the Party against whom enforcement of a waiver is sought. Any waiver by the Parties of any default or breach of any covenant, condition, or term contained in this Agreement, shall not be construed to be a waiver of any subsequent or other default or breach, nor shall failure by the Parties to require exact, full, and complete compliance with any of the covenants, conditions, or terms contained in this Agreement be construed as

changing the terms of this Agreement in any manner or preventing the Parties from enforcing the full provisions hereof.

19. Rights and Remedies Cumulative. Except with respect to rights and remedies expressly declared to be exclusive in this Agreement, the rights and remedies of the Parties are cumulative and the exercise by either Party of one or more of such rights or remedies shall not preclude the exercise by it, at the same or different times, of any other rights or remedies for the same default or any other default by the other Party.

20. Legal Action. In addition to any other rights or remedies, either Party may take legal action, in law or in equity, to cure, correct or remedy any default, to recover damages for any default, to compel specific performance of this Agreement, to obtain declaratory or injunctive relief, or to obtain any other remedy consistent with the purposes of this Agreement.

21. California Law; Venue. This Agreement shall be construed in accordance with the laws of the State of California. Any action commenced about this Agreement shall be filed in the central branch of the Orange County Superior Court.

22. Interpretation. This Agreement shall be construed as a whole according to its fair language and common meaning to achieve the objectives and purposes of the Parties. The terms of this Agreement are contractual and the result of negotiation between the Parties. Accordingly, any rule of construction of contracts (including, without limitation, California Civil Code Section 1654) that ambiguities are to be construed against the drafting party, shall not be employed in the interpretation of this Agreement. The caption headings of the various sections and paragraphs of this Agreement are for convenience and identification purposes only and shall not be deemed to limit, expand, or define the contents of the respective sections or paragraphs.

23. Entire Agreement; Modification. The Contract Documents constitute the entire agreement between the parties and supersedes any previous agreements, oral or written. This Agreement may be modified only by subsequent mutual written agreement executed by DISTRICT and CONTRACTOR.

24. No Third-Party Beneficiaries. Except as may be specifically provided for herein, nothing contained in this Agreement is intended to confer, nor shall this Agreement be construed as conferring, any rights, including, without limitation, any rights as third-party beneficiary or otherwise, upon any entity or person not a party hereto.

25. Severability. Whenever possible, each provision of this Agreement shall be interpreted in such a manner as to be effective and valid under applicable law, but if any provision of this Agreement shall be determined to be invalid by a final judgment or decree of a court of competent jurisdiction, such provision shall be ineffective only to the extent of such prohibition or invalidity, without invalidating the remainder of that provision, or the remaining provisions of this Agreement unless the invalid provision is so material that its invalidity deprives either Party of the basic benefit of their bargain or renders this Agreement meaningless.

26. Corporate Authority. Each of the undersigned represents and warrants that (i) the Party for which he/she is executing this Agreement is duly authorized and existing, (ii) he/she is duly authorized to execute and deliver this Agreement on behalf of the Party for which he/she is signing, (iii) by so executing this Agreement, the Party for which he/she is signing is formally bound to the provisions of this Agreement, and (iv) the entering into this Agreement does not violate any provision of any other Agreement to which the Party for which he/she is signing is bound.

27. Counterparts; Facsimile Signatures. This Agreement may be executed in counterparts, all of which shall constitute the same Agreement, notwithstanding that all parties to this Agreement are not signatory to the same counterpart. Signature and acknowledgement pages may be detached from the counterparts and attached to a single copy of this Agreement to physically form one (1) original document. These counterparts may be transmitted by facsimile or Portable Document Format (PDF), with the originals to be thereafter provided by the Parties. Such facsimiles or electronic copies shall be deemed original signatures.

[SIGNATURES ON FOLLOWING PAGE]

IN WITNESS THEREOF, these parties have executed this Agreement as of the date first written above.

“DISTRICT”

MIDWAY CITY SANITARY DISTRICT,
a public entity

By: _____
Robert Housley
General Manager

APPROVED AS TO FORM:

General Counsel
Midway City Sanitary District

“CONTRACTOR”

PERFORMANCE PIPELINE
TECHNOLOGIES, INC., a California
corporation

By: _____

Name: _____

Title: _____

By: _____

Name: _____

Title: _____

Tax ID No. _____

If CONTRACTOR is a corporation, a Corporate Resolution and/or Corporate Seal is required. If a partnership, Statement of Partnership must be submitted to District.

EXHIBIT A
CONTRACTOR'S PROPOSAL

Performance Pipeline Technologies
5292 System Drive Huntington Beach, CA. 92649
Phone (714) 536-7386

To: Midway City Sanitary District
Attention: Engineering
Project: Emergency Sewer Repair

May 14, 2024
Quote #4171

Scope of work: CIPP Lining of two segments of an 8" sewer main on Webber Street MH 2005 to MH 2006 and Pembroke Street MH 2006 to 2019

Proposal includes the following:

- * All labor Signatory to the union
- * Vactor model cleaning truck
- * CCTV Inspection Truck
- * Pre CCTV and cleaning to ensure the pipe is ready for lining
- * By-Pass pumping
- * Post CCTV Inspection
- * Includes 1 thumb drive with video files and inspection reports.
- * 8" x 6 mm thick x 620'
- * Re Instatement of any active lateral connection
- * No Parking signs

Assumptions, Terms, and Conditions:

- * Resident notification by PPT
- * Water for cleaning will be provided by Midway City Sanitary District
- * Standard Insurance Endorsements any special verbiage additional fee.
- * No retention held on invoices
- * Net 30 Days.
- * This quote becomes part of any contract, agreement, or P.O.

Exclusions:

- * Any permits that may be required, and Bonds

Pricing Lump Sum \$39,760.00

Respectfully Submitted,

Gene Glassburner
Performance Pipeline Technologies
DIR # 1000561121

EXHIBIT B
PLANS AND SPECIFICATIONS

PLANS & SPECIFICATIONS

I. Scope of Work

The Work to be performed includes lining of two segments of 8” sewer lines based on NASSCO Cured-In-Place Pipe (CIPP) Installation Performance Specification Guideline (PSG), 2023 Edition:

1. The first segment of the work is on Webber Pl, Westminster, 350 linear feet from MH2005 to MH2006.
2. The second segment of the work is on Pembroke Ln, Westminster, 270 linear feet from MH2006 to MH2019.

See the attached plans and CIPP PSG 2023. All work shall be done based on Cal/OSHA standards.

II. General Provisions

The following General Provisions apply to the Work.

A. Liability for Costs and Responsibility.

The Contractor will be required to assume responsibility for all services offered in the proposal whether or not they possess them within their firm. The Contractor will be the sole point of contact with regard to contractual matters, including payment of any and all charges resulting from the Contract.

B. Permits.

The Contractor and all of its subcontractors shall obtain and maintain during the term of the Agreement all appropriate permits required in connection with the performance of the Project.

The required permits include:

- Traffic control plans and encroachment permits are required from the City of Westminster.
- Confined Space Permit is required from the District for entering into any District’s manholes. Confined space procedures will be provided with the permit.
- Any other permit which is required by the local agency and the local jurisdiction.

C. Licenses and Certificates.

The Contractor and all of its subcontractors, at its and/or their sole expense, shall obtain and maintain during the term of the Contract, all appropriate licenses and certificates required in connection with the performance of the Project.

The required Licenses and Certificates include:

- General contractor license A, C36, or C42.
- Business Licenses are required from the City of Westminster.
- Any other Licenses and Certificates which is required by the local agency and the local jurisdiction.

D. Spill Prevention and Clean Up.

Spill prevention and clean up shall be performed based on instructions and guidelines by Orange County Public Works Standards that can be found at:

<https://ocerws.ocpublicworks.com/sites/ocpwocerws/files/import/data/files/10193.pdf>

In case of observation of Sewer System Overflow (SSO), please call District's emergency numbers: 714-310-9004 or 714-310-8654.

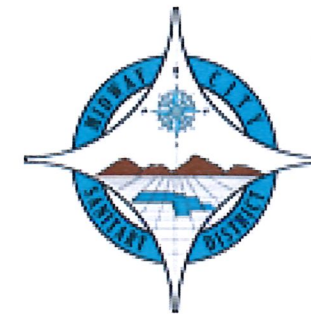

Midway City Sanitary District Emergency Repair Project

DATE: 04/22/2024
SCALE: 1" = 80'



Construction Notes:

1. 350 LF CIPP lining of an 8" sewer main on Webber PI from MH2005 to MH2006 based on NASSCO standards and approved proposal.
2. 270 LF CIPP lining of an 8" sewer main on Pembroke Ln from MH2006 to MH2019 based on NASSCO standards and approved proposal.

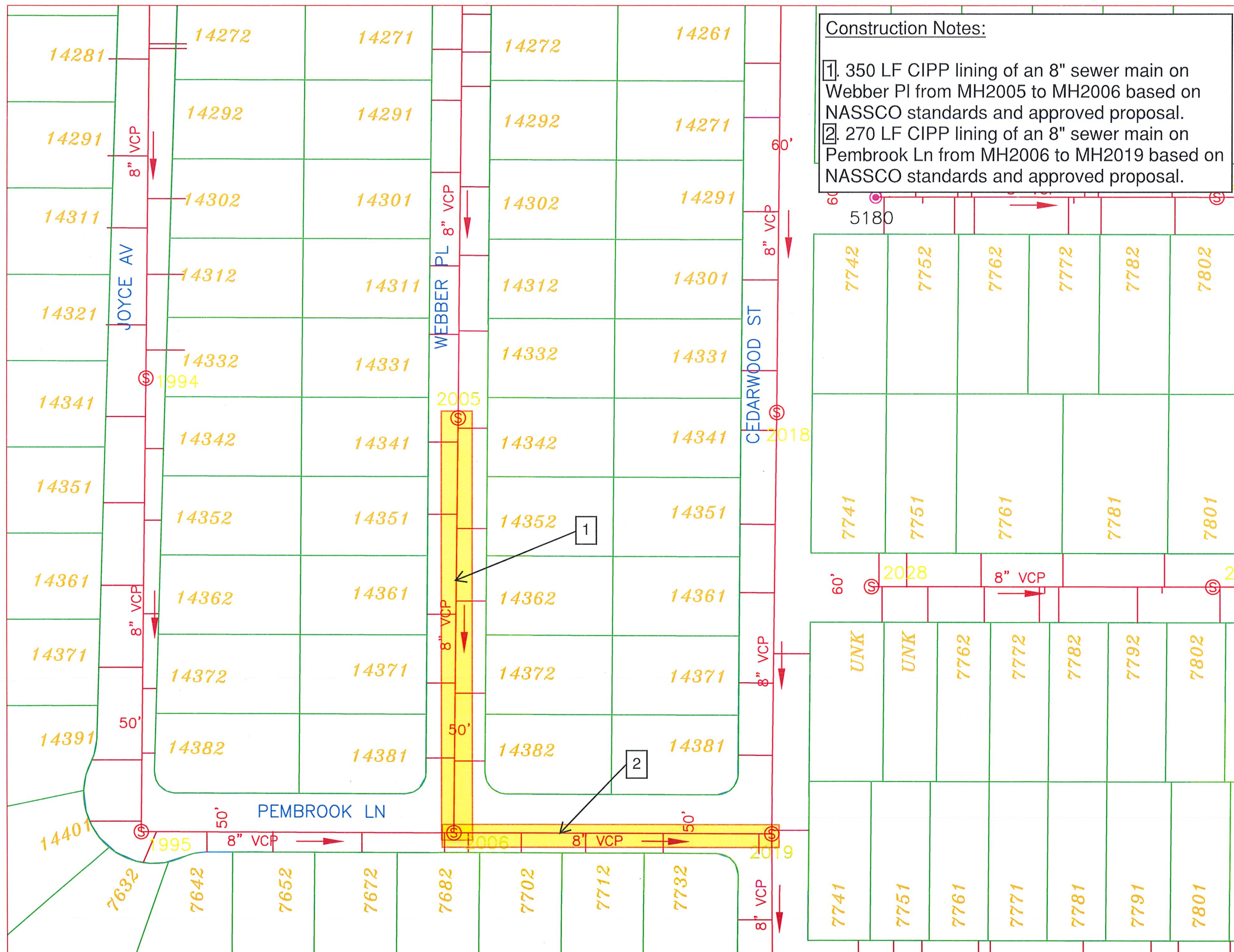

Legend

- Limits of Work
- 13933 Property Number
- Property Line
- MCSD Sewer Line
- OCSD Trunk
- Street Name
- Sewer Manhole
- Flow Direction
- 8" VCP Pipe Size & Type

CURED-IN-PLACE PIPE (CIPP) INSTALLATION

PERFORMANCE SPECIFICATION GUIDELINE (PSG)

June 2023



2023 Edition

NASSCO Pipe Rehab Committee

(Supersedes all previous editions of this document)

© 2023 NASSCO, Inc.
Nassco.org

NASSCO, Inc.
5285 Westview Dr, Suite 202
Frederick, MD 21703

Disclaimer

These Specifications were prepared by a Committee comprised of representatives of NASSCO members and peer-reviewed by industry professionals. These Specifications are not specific to any one product, project, or job site, and should be considered a guideline only. Conditions for use may require additions, deletions or amendments to these guidelines so as to conform to project-specific site conditions and to comply with applicable laws, regulations, and ordinances. NASSCO does not guarantee, certify or assure any result and assumes no liability as to content, use and application of these guidelines

EFFECTIVE SPECIFICATIONS

Effective specifications should encourage the most innovative, efficient and experienced Contractor to provide the level of quality required by the Owner at the best and lowest competitive price.

The specification should not strive to encourage the Contractor to seek the cheapest approach and product delivery available to provide the lowest price.

Effective specifications include the following, which are critical for project success:

1. Product selection for the best solution.
2. Definition of project goals and requirements, both short and long term.
3. Construction means and methods as defined, in writing, by the Contractor.
4. Product provided and installed as specified by the product manufacturer.
5. Product quality and quantity confirmed through inspection and testing.
6. Product design and service life verified through warranty inspection.

Index

PART 1	GENERAL.....	1
1.1	DESCRIPTION OF WORK AND PRODUCT DELIVERY	1
1.2	REFERENCES	3
1.3	PERFORMANCE WORK STATEMENT (PWS) SUBMITTAL	4
1.4	PRODUCT SUBMITTALS	6
1.5	SAFETY.....	7
1.6	QUALITY CONTROL PLAN (QCP)	8
1.7	CIPP REPAIR/REPLACEMENT	9
1.8	AS-BUILT DRAWINGS/RECORDS	9
1.9	WARRRANTY	10
PART 2	PRODUCTS	11
2.1	MATERIALS	11
2.2	FABRIC TUBE.....	11
2.3	RESIN	13
2.4	STRUCTURAL REQUIREMENTS.....	14
2.5	MINIMUM PHYSICAL PROPERTIES.....	14
PART 3	INSTALLATION	15
3.1	CONSTRUCTION REQUIREMNTS	15
3.2	INSTALLATION OF CIPP.....	18
3.3	COOL DOWN	19
3.4	FINISH.....	20
3.5	FLOWABLE FILL OF VOID AREAS	21
3.6	MANHOLE CONNECTIONS AND RECONNECTIONS OF EXISTING SERVICES	21
3.7	TESTING OF INSTALLED CIPP	22
3.8	FINAL ACCEPTANCE.....	24
3.9	TYPICAL BID ITEMS.....	26

PART 1 GENERAL

This performance specification guideline (PSG) is for the rehabilitation of gravity sewers, either sanitary, combined or storm, by the installation of cured-in-place-

- A. This performance specification guideline (PSG) includes the minimum requirements for the rehabilitation of sanitary and storm sewer pipelines by the installation of cured-in-place pipe (CIPP) within the existing, deteriorated pipe as shown on the plans included as part of these contract documents.
- B. The rehabilitation of pipelines shall be done by the installation of a resin-impregnated flexible tube which, when cured, shall be continuous and tight-fitting throughout the entire length of the original pipe. The CIPP shall extend the full length of the original pipe and provide a structurally sound, jointless and water-tight new pipe-within-a-pipe. The Contractor is responsible for proper, accurate and complete installation of the CIPP using the system selected by the Contractor meeting the Owner requirements.
- C. Neither the CIPP product, system, nor its installation, shall cause adverse effects to any of the Owner's processes or facilities. The installation pressure for the product shall not damage the system in any way, and the use of the product shall not result in the formation or production of detrimental compounds or by-products at the wastewater treatment plant. The Contractor shall notify the Owner and identify by-products produced as a result of the installation operations, test and monitor the levels, and comply with local waste discharge requirements. The Contractor shall clean up, restore existing surface conditions and structures, and repair the CIPP system determined to be defective. The Contractor shall conduct installation operations and schedule cleanup in a manner to cause the least possible obstruction and inconvenience to traffic, pedestrians, businesses and property owners or tenants and to provide an environmentally safe restored jobsite.
- D. The prices submitted by the Contractor shall include all costs of permits, labor, equipment and materials for the various bid items necessary for furnishing and installing, complete in place, CIPP in accordance with these specifications. Items of work not specifically mentioned herein which are required, by the Contractor, to make the product perform as intended and deliver the final product as specified herein shall be included in the respective lump sum and unit prices bid.

1.1 DESCRIPTION OF WORK AND PRODUCT DELIVERY

The specifications must include a detailed description of the work required including products that are to be included in the installation, and what is to be delivered by the Contractor.

- A. This PSG covers work necessary to furnish and install the CIPP. The Contractor shall provide materials, labor, equipment, and services necessary for traffic control (if required), bypass pumping and/or diversion of flows, cleaning, measurement and television inspection of sewers to be rehabilitated, CIPP installation, reconnection of service connections, quality controls, provide samples for performance of required material tests, final television inspection, testing of the rehabilitated pipe system, warranty work and other work, as specified herein.
- B. The product furnished shall be a complete CIPP system including specific materials, applicable equipment and installation procedures. If prequalification is required, the CIPP system manufacturer may submit appropriate data/information to the Owner. Other CIPP systems or multi-component products will be required to meet the submittal requirements as contained herein.
- C. The CIPP shall be continuous and jointless from manhole to manhole or access point to access point and shall be free of defects that will affect the long-term life and operation of the pipe.
- D. The CIPP shall not leak at the manholes or through the wall of the installed pipe.-

If the host pipe is in groundwater, the use of end seals, if specified, shall be included to prevent infiltration tracking between the host pipe and CIPP and leaking into the CIPP at manholes.

- E. The CIPP shall be designed for a life of 50 years or greater and an equal service life unless specifically specified otherwise by the Owner.
- F. The CIPP may be designed for partially deteriorated conditions to resist external groundwater pressures only or for fully deteriorated conditions for a structural stand-alone pipe.
- G. The installed CIPP shall comply with the chemical resistance requirements of the relevant ASTM standard(s) F1216, or ASTM D5813 (Section 6.4.1), ASTM F1743 or ASTM F2019.
- H. All existing and confirmed active service connections and any other service laterals to be reinstated, as directed by the Owner, shall be re-opened robotically or by hand in the case of person-entry size piping, to their original shape and to 90% - 95% of their original area. All over-cut or under-cut service connections shall be properly repaired to meet the requirements of these specifications.
- I. All materials furnished as part of this contract shall be marked with detailed product information, stored in a manner specified by the manufacturer and tested to the requirements of this contract.
- J. Testing and warranty inspections shall be executed by the Owner. Defects found shall

be repaired or replaced by the Contractor.

- K. The Contractor shall furnish, from the project installation, samples, marked with chain of custody information such as project name, section, date, diameter and thickness, etc., for product testing at the request of the Owner. The Owner shall take possession of the samples for testing and shall maintain the chain of custody, deliver the samples to an approved laboratory and pay for material and product testing performed under this contract.

1.2 REFERENCES

All applicable reference documents should be listed in this section. If a document does not apply, is not pertinent or has unknown content, it should not be included. Specific reference document requirements should be defined in the contract documents or by reference to a specific section of the document. Specific Contractor requirements and/or test procedures contained in the references should be defined in detail in the contract documents.

- A. The following documents form a part of this specification to the extent stated herein and shall be the latest editions thereof. Where differences exist between codes and standards, the requirements of these specifications shall apply. References to codes and standards shall be to the latest revised version.
- ASCE MOP 145 – Design of Close-Fit Liners for the Rehabilitation of Gravity Pipes
 - ASTM - F1216 Standard Practice for Rehabilitation of Existing Pipelines and Conduits by the Inversion and Curing of a Resin-Impregnated Tube
 - ASTM - F1743 Standard Practice for Rehabilitation of Existing Pipelines and Conduits by the Pulled-in-Place Installation of Cured-in-Place Thermosetting Resin Pipe (CIPP)
 - ASTM - D790 Standard Test Methods for Flexural Properties of Unreinforced and Reinforced Plastics and Electrical Insulating Materials
 - ASTM - F2019 Standard Practice for Rehabilitation of Existing Pipelines and Conduits by the Pulled in Place Installation of Glass Reinforced Plastic Cured-in-Place (GRP-CIPP) Using the UV-Light Curing Method
 - ASTM - D2990 Standard Test Methods for Tensile, Compressive, and Flexural Creep and Creep-Rupture of Plastics

- ASTM - D5813 Standard Specification for Cured-in Place Thermosetting Resin Sewer Pipe
- Guideline for the Safe Use and Handling of Styrene-Based Resins in Cured-in-Place Pipe, NASSCO. 2023.
- Trenchless Technology Center at Louisiana Tech, 2019. NASSCO CIPP Emissions Phase 2: Evaluation of Air Emissions from Polyester Resin CIPP with Steam Cure
- Trenchless Technology Center at Louisiana Tech, 2023. NASSCO CIPP Emissions Phase 3 “Evaluation of Styrene Emissions Associated with Various CIPP Coatings in Refrigerated Storage” Final Report

1.3 PERFORMANCE WORK STATEMENT (PWS) SUBMITTAL

In place of the engineer defining the specific method for product installation, the contractor defines the installation means and methods through a written plan called the Performance Work Statement (PWS). During construction the PWS provides valuable information to the inspector so that the inspector can determine if the submitted means and methods are being followed by the contractor. The PWS also outlines the necessary quality checks to be performed and the installation crew qualifications.

- A. The Contractor shall submit, to the Owner, a Performance Work Statement (PWS) which clearly defines the CIPP product delivery in conformance with the requirements of these contract documents. Unless otherwise directed by the Owner, the PWS shall, at a minimum, contain the following:
 - B. Clearly indicate that the CIPP will conform to the project requirements as outlined in the Description of Work and as delineated in these specifications.
 - C. A detailed product installation plan describing preparation work, cleaning operations, pre-CCTV inspections, bypass pumping, traffic control, installation procedure, method of curing, service reconnection, quality control, testing to be performed, final CCTV inspection, warranties furnished necessary and appropriate for a complete CIPP installation. An installation schedule shall be prepared, submitted and conform to the requirements of this contract.
 - D. Contractor’s description of the proposed CIPP technology, including a plan for identifying active service connections maintaining service, during mainline CIPP installation, to each home connected to the section of pipe being rehabilitated, including temporary service for commercial, industrial and apartment complexes, if required by the contract.
 - E. A description of the CIPP materials to be furnished for the project. Materials shall be identified in the submittals and conform to these specifications and/or shall conform to the pre-approved product submission.

- F. A statement of the Contractors experience. The Contractor shall have a minimum of three (3) years of cumulative experience installing CIPP in pipe of a similar size, length and configuration as contained in this contract. The lead personnel, including the superintendent, the foreman and the lead crew personnel for the CCTV inspection, resin wet-out, the CIPP installation, curing and the robotic service reconnections each

must have a minimum of one (1) year of experience with the CIPP technology proposed for this contract and must have demonstrated competency and experience to perform the scope of work contained in this contract. The name and experience of each lead individual performing work on this contract shall be submitted with the PWS. Personnel replaced by the Contractor, on this contract, shall have similar, verifiable experience as the personnel originally submitted for the project

If the design calculations include mechanical properties greater than the minimum properties listed in these specifications, the mechanical properties included in the design calculations become the minimum acceptable values when testing field samples.

- G. Engineering design calculations, in accordance with the Appendixes of ASTM F1216, or ASTM F2019, ASCE MOP 145, or other design protocol as specified by the owner, for each length of CIPP to be installed including the thickness of each proposed CIPP. It will be acceptable for the Contractor to submit a design for the most severe line condition and apply that design to all the line sections. These calculations shall be performed and certified by a qualified Professional Engineer. All calculations shall include data that conforms to the requirements of these specifications or has been pre-approved by the Owner.
- H. Proposed manufacturers' technology data shall be submitted for all CIPP products and all associated technologies to be furnished.

Reinstating service laterals is a critical operation for completing small diameter CIPP installations. This specialty type equipment is not readily available for rent from local equipment rental companies. Because of this, often redundant robotic cutters are specified for small diameter projects with service laterals.

- I. Submittals shall include information on CIPP intended for installation and tools and equipment required for a complete installation. The PWS shall identify which tools and equipment will be redundant on the job site in the event of equipment breakdown. Equipment to be furnished for the project, including proposed back-up equipment, shall be clearly described. The Contractor shall outline the mitigation procedure to be implemented in the event of key equipment failure during the installation process.

Non-specialty backup equipment should be identified and reserved by the Contractor (on will call) from local rental companies in the event of equipment failure.

- J. A description of the Contractor's proposed procedures for removal of existing blockages in the pipeline that may be encountered during the cleaning process.

Proper public notification can prevent many public relations issues during a project. If the residents know that there will be workers and equipment near their homes, that they should not use large volumes of water or that they may smell strange odors, many homeowner concerns and problems can be prevented.

- K. A public notification plan shall be prepared and submitted including detailed staged notification to residences affected by the CIPP installation.

CIPP installations commonly include the use of resins which contain a styrene component. These resins can emit a distinctive odor from the styrene component. To minimize this nuisance odor the contractor should devise an odor control plan that will mitigate the nuisance effect to the general public and residents at the project site during the CIPP installation.

- L. An odor control plan shall be submitted by the Contractor that will ensure that project specific odors will be minimized at the project site and surrounding area. Part of the plan will include methods for removing odors from residents' homes, if required.
- M. Compensation for work required for the submittal of the PWS shall be included in the various pipelining items contained in the Proposal.

1.4 PRODUCT SUBMITTALS

Product submittals require the contractor to submit the materials to be incorporated in the installation. This also allows the contractor to submit alternative materials that may be equal or better than those specified. The engineer must be prepared to evaluate alternative materials through evaluation, certifications and third-party testing to validate alternative materials meet the specified requirements of the contract.

This section includes a list of significant CIPP products and procedures that should be included in the submittal package. These include the two principal products, the tube and the resin, in addition to handling and storing these items from the manufacturing plant to the wet-out facility. Also included are detailed procedures for wet-out, installation and curing.

- A. Tube – including the manufacturer and description of product components (i.e., felt, fiberglass and other reinforcing materials) and applicable tube mechanical properties.
- B. Flexible membrane – including materials (i.e., coating, foil) specific to the proposed curing method and recommended repair (patching) procedure if applicable.
- C. Resin - including the manufacturer and description of product components including

the spectroscopic wavelength diagram for the resin being furnished as well as mechanical properties, corrosion data and creep data.

- D. Manufacturers' shipping, storage and handling recommendations for all components of the CIPP system.
- E. Safety Data Sheets (SDS) for all materials to be furnished for the project.
- F. Tube wet-out and cure method including:
 - 1. A description of the wet-out procedure for the proposed technology. In the case of tubes wet-out by a third party, the wet-out information from the third-party source.
 - 2. The Manufacturer's recommended cure method for each diameter and thickness of CIPP to be installed. The PWS shall contain a detailed curing procedure outlining the curing medium, the method of application and how the curing process will be monitored (e.g., temperatures, pressure, output of light, rate of travel of light train assembly).
- G. Compensation for all work required for the submittal of product data shall be included in the Lump Sum price contained in the Proposal for Mobilization.

<p>Worker safety should be the number one priority on a job site. No work should start until the Contractor submits a safety plan, and all work should be conducted in accordance with the safety plan. The plan should be sufficiently detailed to describe daily safety meeting requirements, procedures and documentation. Emergency procedures and location of medical facilities should be identified</p>
--

1.5 SAFETY

- A. The Contractor shall conform to work safety requirements of pertinent regulatory agencies and shall secure the site for the working conditions in compliance with the same. The Contractor shall erect signs and other devices as are necessary for the safety of the work site.
- B. The Contractor shall perform the Work in accordance with applicable OSHA standards. Emphasis shall be placed upon the requirements for entering confined spaces and with the equipment being utilized for pipe renewal.
- C. The Contractor shall submit a proposed Safety Plan to the Owner prior to beginning any work, identifying all competent persons. The plan shall include a description of a daily safety program for the job site and all emergency procedures to be implemented in the event of a safety incident. The Safety Plan shall include safety recommendations for mitigating styrene emissions on heat-cure CIPP job sites that have a potential to

pose health risks to workers. Refer to TTC's Emissions Phase 2 and Phase 3 Reports and NASSCO's Styrene Guideline (See 1.2 REFERENCES). Work shall be conducted in accordance with the Contractor's submitted Safety Plan.

- D. Compensation for work required for the submittal of the Safety Plan shall be included in the pipelining items contained in the Proposal.

1.6 QUALITY CONTROL PLAN (QCP)

A Quality Control Plan (QCP) should be submitted by the Contractor. The QCP should include a discussion of the proposed quality controls to be performed by the Contractor, including material protection and handling, equipment operation and documentation requirements. The Contractor personnel, including names and cell phone numbers for those that are responsible for assuring that all quality requirements are met, should be identified and submitted.

- A. A Quality Control Plan (QCP) that represents and conforms to the requirements of these specifications shall be submitted to the Owner. At a minimum the QCP shall include the following:
 1. A discussion of the proposed quality controls to be performed by the Contractor.
 2. Defined responsibilities, of the Contractor's personnel, for assuring that quality requirements for this contract are met. These shall be assigned by the Contractor to specific personnel.
 3. Proposed procedures for quality control, product sampling and testing shall be defined and submitted as part of the plan.
 4. Proposed methods for product performance controls, including method of and frequency of product sampling and testing both in raw material form and cured product form.
 5. Scheduled performance and product test result reviews between the Contractor and the Owner at a regularly scheduled job meeting.
 6. Inspection forms and guidelines for quality control inspections shall be prepared in accordance with the standards specified in this contract and submitted with the QCP.

Success of a CIPP installation leverages an industry standard of care performance specification and an inspector that understands CIPP quality control procedures required on a project. The inspector should be trained and knowledgeable in where the product is applicable, technology procedures, material wet-out, curing requirements, acceptability standards and required testing.

1.7 CIPP REPAIR/REPLACEMENT

As part of the PWS, the Contractor should submit repair and replacement procedures for common CIPP defects. Defects should be categorized as those that need no repair, those that can be repaired and those that must be removed and replaced. Defects that affect the operation and/or longevity of the CIPP should be repaired or replaced.

- A. Occasionally installations will result in the need to repair or replace a defective CIPP. The Contractor shall outline specific repair or replacement procedures for potential defects that may occur in the installed CIPP. Repair/replacement procedures shall be as recommended by the CIPP system manufacturer and shall be submitted as part of the PWS.
- B. Defects in the installed CIPP that will not affect the operation and long-term life of the product shall be identified and defined.
- C. Repairable defects that may occur in the installed CIPP shall be specifically defined by the Contractor based on manufacturer's recommendations, including a step-by-step repair procedure, resulting in a finished product meeting the requirements of these contract specifications.
- D. Unrepairable defects that may occur to the CIPP shall be clearly defined by the Contractor based on the manufacturer's recommendations, including a recommended procedure for the removal and replacement of the CIPP.

1.8 AS-BUILT DRAWINGS/RECORDS

As-Built drawings/records include the identification of the work completed by the Contractor and should include the pre- and post-inspection documentation. As-Built drawings /records should be kept current and should be available on the project site at all times. As-Built drawings/records can be in the form of actual drawings, either paper or electronic, spreadsheets or Word documents.

- A. As-Built drawings/records, pre and post inspection videotapes, CDs or other electronic media shall be submitted to the Owner, by the Contractor, within 2 weeks of final

acceptance of said work or as specified by the Owner. As-Built drawings/records will include the identification of the work completed by the Contractor and shall be prepared on one set of Contract Drawings/Records provided to the Contractor at the onset of the project.

- B. As-Built drawings/records shall be kept on the project site at all times, shall include all necessary information as outlined in the PWS or as agreed to by the Owner and the Contractor at the start of the Contract, shall be updated as the work is being completed and shall be clearly legible.
- C. Compensation for work required for the submittal and approval of As-Built drawings/records shall be included in the various pipelining items contained in the Proposal.

1.9 WARRANTY

The Contractor should warrant the CIPP material and installation for a period as specified. If required by the Owner, the Contractor should warrant defective work that has been repaired for an extended period as agreed. After completion of the work but before the warranty period has expired, the owner should inspect a portion of the rehabilitated system. Initial warranty inspection should include up to 15% of the completed work. The warranty inspection should be based on the recommendations documented by the project inspector during the execution of the project. Defects found should be remedied in accordance with the repair/replacement plan submitted in the PWS. Depending on the frequency of defects found, the Owner may inspect more installations, as necessary.

- A. The materials used for the project shall be certified by the manufacturer for the specified purpose. The Contractor shall warrant the CIPP material and installation for a period of one (1) year. During the Contractor warranty period, any defect which may materially affect the integrity, strength, function and/or operation of the pipe, shall be repaired at the Contractor's expense in accordance with procedures included in Section 1.7 CIPP Repair/Replacement and as recommended by the manufacturer.
- B. For work completed by the Contractor that is defective and/or has been repaired, the Contractor shall warrant this work for (1) year in addition to the warranty required by the contract.
- C. After a pipe section has been rehabilitated and for a period of time up to one (1) year following completion of the project, the Owner may inspect all or portions of the rehabilitated system. The specific locations will be selected at random by the Owner's inspector and should include all sizes of CIPP from this project. If it is found that any of the CIPP has developed abnormalities since the time of "Post Construction Television Inspection," the abnormalities shall be repaired and/or replaced as defined in Section 1.7 CIPP Repair/Replacement and as recommended by the manufacturer.

If, after inspection of a portion of the rehabilitated system under the contract, problems are found, the Owner may televise all the CIPP installed on the contract. All verified defects shall be repaired and/or replaced by the Contractor and shall be performed in accordance with Section 1.7 CIPP Repair/Replacement and per the original specifications, all at no additional cost to the Owner.

PART 2 PRODUCTS

2.1 MATERIALS

The cured CIPP product must meet the chemical resistance requirements specified as referenced in the relative ASTM standard(s) F1216, ASTM F1743, ASTM D5813 (Section 6.4.1), or ASTM F2019. The tested product should be the same type of tube and resin used on the project. Chemical resistance testing is a qualification test that is typically completed by the resin manufacturer who then certifies that the product meets the specified requirement. This certification, which can be accompanied by the test report, is submitted by the contractor prior to the start of the project.

- A. The CIPP System must meet the chemical resistance requirements of these contract documents.
- B. Materials shipped to the project site shall be accompanied by test reports certifying that the material conforms to the appropriate ASTM standards listed herein. Materials shall be shipped, stored, and handled in a manner consistent with written recommendations of the CIPP system manufacturer to avoid damage. Damage includes, but is not limited to, gouging, abrasion, flattening, cutting, puncturing or ultra- violet (UV) degradation. On-site storage locations shall be approved by the Owner. Damaged materials shall be promptly removed from the project site at the Contractor's expense and disposed of in accordance with all current applicable agency regulations.

2.2 TUBE

The tube is the vehicle that carries the resin into the pipeline and holds the resin in place prior to and during cure. The thickness of the tube and installation procedures determine the finished thickness of the CIPP. A properly designed and specified tube is critical to achieving the specified finished CIPP thickness.

- A. The tube shall consist of one or more layers of absorbent non-woven felt fabric, felt/fiberglass, felt/carbon fiber, carbon fiber or fiberglass and meet the material requirements of ASTM F1216, ASTM F1743, or ASTM F2019 and ASTM D5813 as applicable. The tube shall be capable of absorbing and carrying resins, constructed to withstand installation pressures and curing temperatures and have sufficient strength to bridge missing pipe segments and stretch to fit irregular pipe sections. The

Contractor shall submit certified information from the tube manufacturer on the nominal void volume in the felt fabric that will be filled with resin or the recommended saturation rates using the proposed resin.

- B. The wet-out tube ("liner") shall have a uniform thickness and excess resin distribution that when compressed at installation pressures will meet or exceed the design thickness after cure.
- C. The tube shall be manufactured to a size and length that when installed will tightly fit the internal circumference of the original pipe. Allowance shall be made for circumferential stretching during installation. The tube shall be properly sized to the diameter of the existing pipe and the length to be rehabilitated and be able to tolerate circumferential changes to fit irregular pipe sections and negotiate bends. The Contractor shall determine the minimum tube length necessary to effectively span the designated run between manholes. The Contractor shall verify the lengths in the field prior to ordering and prior to impregnation of the tube with resin to ensure that the tube will have sufficient length to extend the entire length of the run. The Contractor shall also measure the inside diameter of the existing pipelines in the field prior to ordering tube so that the CIPP can be installed in a tight-fitting condition.
- D. The outside and/or inside layer of the tube (before inversion/pull-in, as applicable) shall be coated or covered with an impermeable, flexible membrane that will contain the resin and facilitate, if applicable, vacuum impregnation and monitoring of the resin saturation during the resin impregnation (wet-out) procedure.
- E. No material shall be included in the tube that may cause delamination in the cured CIPP. No dry or unsaturated layers shall be acceptable upon visual inspection as evident by color contrast between the tube and the activated resin containing a colorant, if a colorant is utilized.
- F. The wall color of the interior pipe surface of CIPP after installation shall be a light reflective color so that a clear detailed examination with closed circuit television inspection equipment may be made. The color contrast shall be sufficient to distinguish between the fully resin saturated tube and dry or resin lean areas.
- G. Seams in the tube, if applicable, shall meet the requirements of section 7.1 of ASTM F1743.
- H. The outside of the tube shall be marked at a maximum of every 5 feet with the name of the manufacturer or CIPP system, manufacturing lot and production footage.
- I. The minimum length of the tube shall be that deemed necessary by the installer to effectively span the distance from the starting manhole to the terminating manhole or access point, plus that amount required to run-in and run-out for the installation process.

- J. The nominal tube wall thickness shall be constructed, as a minimum, to a sufficient thickness that exceeds the required design thickness for that section of installed CIPP. Wall thickness transitions may be fabricated into the tube between installation entrance and exit access points. The volume of resin used in the impregnation shall be sufficient to fully saturate the tube.

2.3 RESIN

In felt tube CIPP, the resin is the structural pipe. In reinforced tube CIPP, the resin is important in providing the structural matrix so that the reinforcing fibers can significantly increase the CIPP's mechanical properties. Thus, it is important that the applicable resin for the pipe's flow characteristics is specified and delivered to the wet-out facility. The project representative should verify that the resin specified or substituted by the Contractor meets the contract specified requirements. The inspector should verify that the specified or approved resin is supplied by the Contractor and correct amount of resin is added to the tube at the wet-out facility. This information can be verified from the spectroscopic wavelength diagram of the resin, the tube wet-out report and standard resin saturation charts furnished from the suppliers of the resin and tube.

- A. The resin shall be a corrosion resistant polyester or vinyl ester resin and catalyst system or epoxy resin and hardener system that, when properly cured within the tube composite, meets the requirements of ASTM F1216, ASTM F1743 or ASTM F2019, the mechanical properties herein, and those which are to be utilized in the design of the CIPP for this project. The resin, specified for the specific application defined in the contract documents, shall produce CIPP which will comply with or exceed the structural and chemical resistance requirements of this specification.
- B. The resin to tube ratio, by volume, shall be furnished as recommended by the CIPP tube manufacturer.

2.4 STRUCTURAL REQUIREMENTS

The calculated design thickness typically determines the minimum installed CIPP thickness. However, in small diameter CIPP, such as 8", the calculated thickness may be quite small depending upon the design loads. The minimum installed CIPP thickness in these cases should consider the minimum thickness required for maintenance activities such as pressure jetting and abrasion and damage from materials and objects in the pipe flow. Also, the risk of leakage through the CIPP wall increases as the wall becomes thinner. Under these circumstances, a minimum wall thickness greater than the calculated design thickness may be prudent. The type of CIPP product, for example felt or glass tube, should be considered.

- A. The mechanical properties and physical characteristics of the finished CIPP will vary

considerably, depending on the types and mixing proportions of the materials used and the degree of cure executed. It shall be the responsibility of the Contractor to control these variables and to provide a CIPP system which meets or exceeds the minimum properties specified herein or as submitted in the PWS.

- B. The CIPP shall be designed as per ASTM F1216 Appendix X1, ASTM F2019 Appendix X1, or ASCE MOP 145. The CIPP design shall assume no bonding to the original pipe wall.
- C. The design engineer shall set the long-term (50 year extrapolated) Creep Retention Factor at 50% of the initial design flexural modulus as determined by ASTM D790 test method. This value shall be used unless the Contractor submits long-term test data (ASTM D2990) to substantiate a higher retention factor.
- D. The cured pipe material (“CIPP”) shall, at a minimum, meet or exceed the mechanical properties, as listed below or as submitted in the PWS.

2.5 MINIMUM MECHANICAL PROPERTIES

Property	Test Method	Cured Composite Per ASTM F1216 or F1743	Cured Composite Per ASTM F2019	Cured Composite Per Design
Flexural Modulus of Elasticity	ASTM D790	250,000 psi	Declared Value but not less than 725,000 psi	Contractor Value
Flexural Strength	ASTM D790	4,500 psi	Declared Value but not less than 15,000 psi	Contractor Value

- A. The required CIPP wall thickness shall be based, as a minimum, on the mechanical properties of the cured composite and per the design of the Professional Engineer (see section 1.3.G) and in accordance with the design equations contained in Appendix X1 of ASTM F1216, Appendix X1 of ASTM F2019, or ASCE MOP 145 and the following design parameters:

Design Safety Factor	2.0 (1.5 for pipes 36" or larger, if applicable)
Creep Retention Factor	50% or otherwise verified by test data
Ovality	2% or as measured by field inspection
Constrained Soil Modulus	Per AASHTO LRFD Section 12 and AWWA Manual M45
Groundwater Depth	As specified or indicated on the Plans
Soil Depth (above the crown)	As specified or indicated on the Plans
Live Load	Highway, railroad, airport or permanent structures as applicable
Soil Load (assumed)	120 lb./cu. ft. or as specified

ASCE MOP 145 does not use a safety factor and includes three Design States [I, II, or III]. MOP 145 design is based on LRFD (load and resistance design factors), and the appropriate parameters depend on the Design State used and are defined in the MOP.

- B. The Contractor shall submit, prior to installation of the lining materials, certification of compliance with these specifications and/or the requirements of the pre-approved CIPP system. Certified material test results shall be included that confirm that materials conform to these specifications and/or the pre-approved system. Materials not complying with these requirements will be rejected.
- C. The design soil modulus may be adjusted based on data, determined from project soil testing results, as provided by the Owner in the contract documents.

PART 3 INSTALLATION

3.1 CONSTRUCTION REQUIREMENTS

The construction requirements cover on-site activities needed for proper installation of the CIPP product. Construction activities (cleaning, inspection, measurement, bypass, etc.) should have been explained in the PWS submitted by the Contractor. Inspection and testing requirements, during construction, should be defined for the Contractor and the inspector. The Contractor shall keep wet-out and curing logs for inspection by the Owner or Owner's project representative.

- A. The liner shall be constructed of materials and methods that, when installed, shall

provide a continuous structurally sound CIPP able to withstand all imposed static and dynamic loads on a long-term basis as required in the specifications.

- B. The Contractor may, under the direction of the Owner, utilize existing manholes in the project area as installation access points. If a street must be closed to traffic because of the location of the sewer, the Contractor shall furnish a detailed traffic control plan with necessary labor and equipment. The plan shall be in conformance with the requirements of the local agency having jurisdiction over traffic control.
- C. Cleaning of Pipelines – Before ordering tube materials for the project, the Contractor shall remove debris from inside the pipeline that will interfere with the installation and the final product delivery of the CIPP, as required in these specifications, and accurately measure and document the diameter and length of the existing pipeline to be rehabilitated. Solid debris and deposits shall be removed from the system and disposed of properly by the Contractor. Moving material from manhole section to manhole section shall not be allowed. As applicable, the Contractor shall either plug or install a flow bypass pumping system to properly clean the pipelines. Precaution shall be taken by the Contractor in the use of cleaning equipment to avoid damage to the existing pipe. The repair of any damage, caused by the cleaning equipment, shall be the responsibility of the Contractor. The Owner will designate a site for the disposal of debris removed from the Owner’s sewer system as a result of the cleaning operation. Unless otherwise specified by the Owner, the Contractor shall dispose of debris at no charge. Should dumping fees apply, the Contractor shall be compensated at the respective unit price bid in the Proposal for cleaning.
- D. Bypassing Existing Flows - The Contractor shall provide for the flow of existing mainline and service connection effluent, if applicable, around the section or sections of pipe designated for CIPP installation. With most small diameter pipelines, particularly on terminal sewers, plugging will be adequate but must be monitored on a regular basis to prevent backup of sewage into adjacent homes. Service connection effluent may be plugged, if required, only after proper notification to the affected residence and may not remain plugged overnight. Installation of the CIPP shall not begin until the Contractor has installed the required plugs, or a sewage bypass system, and all pumping facilities have been installed and tested under full operating conditions including the bypass of mainline and side sewer flows, if required. Once the installation has begun, existing flows shall be maintained, until the CIPP is fully cured, cooled down, fully televised and the CIPP ends finished. The Contractor shall coordinate sewer bypass and flow interruptions with the Owner at least 7 days in advance. The pump and bypass lines shall be of adequate capacity and size to handle peak flows. The Contractor shall submit a detail of the bypass plan and design to the Owner before proceeding with any CIPP installation. Compensation for bypass pumping and all associated plans and approvals shall be at the price bid in the Proposal.
- E. Contractor shall perform post-cleaning video inspections of the pipelines. Only PACP certified personnel trained in locating defects, obstacles and service connections by

closed circuit television shall perform the inspection. The Contractor shall provide the Owner a copy of the pre-cleaning and post-cleaning video and suitable log, and/or in digital format, for review prior to installation of the CIPP and for later reference by the Owner.

- F. Line Obstructions - It shall be the responsibility of the Contractor to clear the line of obstructions that will interfere with the installation and long-term performance of the CIPP. If pre-installation inspection reveals an obstruction, misalignment, broken or collapsed section or sag that was not identified as part of the original scope of work and will prohibit proper installation of the CIPP, the Contractor may be directed by the Owner to correct the problem(s) prior to installation by utilizing open cut repair methods. The Contractor shall be compensated for this work under a contingency pay item designated for open cut point repairs. Removal of previously unknown obstructions shall be considered as a changed condition. The cost of removal of obstructions that appeared on pre-bid video documentation and made available to the Contractor, prior to the bid opening, shall be compensated for on a unit price basis in accordance with the contract documents.
- G. The Contractor shall be responsible for confirming the locations of all branch service connections prior to installing the CIPP. If required in the contract documents, each connection will be dye tested to determine whether or not the connection is live or abandoned. Other approved methods to confirm live connections are acceptable. The cost for dye testing of existing service connections shall be compensated at the unit price bid in the Proposal for Dye Testing of Existing Service Connections. In the event the status of a service connection cannot be adequately defined, the Owner will make the final decision, prior to installation of the CIPP, as to the status. Typically, only service connections deemed "active" shall be reopened by the Contractor.
- H. The Contractor shall be allowed use water from an owner-approved fire hydrant in the project vicinity. Use of an approved double check backflow assembly shall be required. Contractor shall provide his own approved assembly. Contractor shall pay current market price for all water usage.

3.2 INSTALLATION OF CIPP

It is important that the CIPP be installed in accordance with the manufacturer's recommendations. These procedures should have been outlined in the PWS submitted by the Contractor. Recommended procedures that should be monitored include: Installation speed and pressure, the cure schedule and curing temperature monitoring must be maintained and documented, as recommended by the manufacturer. Chemical grouting should be utilized, or a pre-liner should be installed, where the infiltration into the pipeline is excessive and may affect the cure and/or the final structure of the CIPP unless the tube has an outer coating or film.

- A. The CIPP shall be installed and cured in the host pipe per the manufacturer's specifications as described and submitted in the PWS.
- B. CIPP installation shall be in accordance with the applicable ASTM standards as modified in this Section 3.2.
- C. If significant groundwater infiltration is present in the existing sewer, such as PACP defects coded "infiltration gusher" or multiple "runners", the Contractor shall install a preliner or perform chemical grouting to control resin loss and contamination, maintain CIPP thickness, prevent mechanical property reduction and prevent inadequate curing of the CIPP resulting from water or other contamination of the resin during installation. The preliner shall be a plastic tube to fit the existing pipeline and shall be continuous from manhole (access) to manhole (access). Preliners are not required in this situation when using pulled-in liners with exterior coatings or in the case of light cured liners (i.e., UV or LED) that contain an outer membrane.
- D. The liner shall be positioned in the pipeline using the method specified by the manufacturer. Care should be exercised not to damage the liner during installation. The liner should be pulled-in or inverted through an existing manhole or approved access point and fully extend to the next designated manhole or termination point in accordance with ASTM F1216, ASTM F1743, or ASTM F2019, and the manufacturer's recommendations.
- E. When Using Hot Water or Steam Cure: Prior to installation and as recommended by the manufacturer, remote temperature gauges or sensors shall be placed inside the host pipe to monitor the temperatures during the cure cycle. CIPP and/or host pipe interface temperature shall be monitored and logged during cure.

To monitor the temperature of the CIPP wall and to verify correct curing, where specified by the contract documents, temperature monitors can be placed between the host pipe and the CIPP in the bottom of the host pipe (invert) at manholes or access points and/or throughout its entire length (continuous) to monitor the temperature on the outside of the CIPP during the curing process.

Curing shall be accomplished by utilizing the appropriate medium in accordance with the manufacturer's recommended cure procedure and/or schedule. The curing source or in and output temperatures shall be monitored and logged during the cure cycles, if applicable. The manufacturer's recommended cure method and schedule shall be used for each line segment installed, and the CIPP wall thickness and the existing ground conditions with regard to temperature, moisture level, and thermal conductivity of soil shall be taken into account by the Contractor.

If any temperature sensor or continuous sensor location does not reach the temperature as specified by the manufacturer to achieve proper curing or cooling, the installer can make necessary adjustments to comply with the manufacturer's recommendations. For continuous temperature monitoring, the system computer should have an output report that specifically identifies stations along the length of pipe, indicates the maximum temperature achieved and the sustained temperature time at the stations. At each station along the length of the pipe, the computer should record both the maximum temperature and the minimum cool down temperature and comply with the manufacturer's recommendations.

When using hot water or steam cure methods, monitoring cure temperatures is important for verifying the correct cure of the resin. Temperatures can be monitored continuously in time and location throughout the pipeline being rehabilitated by using a fiber optic cable sensing system installed in the pipe invert prior to CIPP installation. Continuous monitoring systems are computer controlled with a real-time screen display and can be monitored by any smart device. This is especially useful for critical sewers and medium to large diameter sewers. As a minimum, standard thermocouples, which measure temperatures at one point, should be used, typically at the pipe invert in the termination manhole. Often thermocouples are used in addition to continuous monitoring systems to verify proper cure of the CIPP.

- F. When Using Photoinitiated Reaction (i.e., UV or LED light cure): A protocol shall be defined by the manufacturer and recorded during the cure process and maintained as documentation to verify cure. Data collected shall include time, rate of travel of the light curing assembly for dynamic curing processes, pressures, temperature in the liner and the power output of the light assembly along the entire length of the installed CIPP. The cure procedure shall be in accordance with ASTM F1216, ASTM F1743, or ASTM F2019 and the manufacturer's recommendation as included in the PWS submission by the Contractor.

3.3 COOL DOWN

Proper cool down of CIPP is important to help minimize CIPP shrinkage and cracking. The temperature profile and times required should be provided as a part of the cure schedule. Short cuts that reduce the cool down time should not be allowed.

- A. The Contractor shall cool the CIPP in accordance with the approved CIPP manufacturer's recommendations as described and outlined in the PWS.
- B. Temperatures and curing data shall be monitored and recorded by the Contractor throughout the installation process to ensure that each phase of the process is achieved as approved in accordance with the CIPP system manufacturer's recommendations.

3.4 FINISH

Any defect which could affect the structural integrity or longevity of the CIPP should be repaired. Sealing the ends of the CIPP at manholes and at service connection openings, if specified, is important in cases where the sewer is below the groundwater surface elevation. Leaks through the wall of the CIPP are considered a defect.

- A. The installed CIPP shall be continuous over the entire length of a sewer line section and be free from visual defects such as foreign inclusions, dry spots, pinholes, major wrinkles and delamination. The CIPP shall be impervious and free of leakage through the CIPP wall.
- B. Any defect which will or could affect the structural integrity or strength of the CIPP shall be repaired at the Contractor's expense in accordance with the procedures submitted under Section 1.7 CIPP Repair/Replacement.
- C. The beginning and end of the CIPP shall be sealed to the existing host pipe, if specified. The sealing material shall be compatible with the pipe end and shall provide a watertight seal.
- D. If any of the service connections leak water between the host pipe and the installed CIPP, the connection mainline interface shall be sealed, if required by these specifications, to provide a leak tight connection.
- E. If the wall of the CIPP leaks, it shall be repaired or removed and replaced with a watertight pipe as recommended by the manufacture of the CIPP system.
- F. Compensation shall be at the actual length of CIPP installed. The length shall be measured from center of manhole to center of manhole. The unit price per linear foot installed shall include materials, labor, equipment and supplies necessary for the complete CIPP installation. Compensation for service connection sealing and pipe sealing at the manhole/wall interface shall be at the unit price bid in the Proposal.

The long-term structural capability of the existing underground pipeline is defined by the pipe design and the surrounding soil structure. When a CIPP is installed through an existing pipe that represents such defects as soil visible or soil missing, the engineer should consider that the soils be replaced using a flowable fill technique to provide soils support for the newly installed CIPP.

3.5 FLOWABLE FILL OF VOID AREAS

- A. Where required by the Owner, the Contractor shall backfill known voids that remain

after installation of CIPP. The material shall be of the flowable fill type and shall be injected into the void while removing all trapped air from the void. The Contractor shall submit the proposed method of placing the flowable fill, including pressures that will not collapse the CIPP and air release method to be employed, to the Owner for review before material is installed. The cost of this work shall be at the unit price bid for flowable fill and include all material, equipment, and labor to complete the filling of the soil void

3.6 MANHOLE CONNECTIONS AND RECONNECTIONS OF EXISTING SERVICES

The most common method of sealing the CIPP at manholes is to install a hydrophilic rubber seal prior to installing the CIPP. Sealing the CIPP at manholes after the CIPP has been installed is possible but less effective. Side connections should be cut open to at least 90%-95% of the original service connection opening area. In all cases, the invert of the lateral connection shall be cut flush with the invert entering the mainline to eliminate debris build-up.

- A. A seal, consisting of a resin mixture or hydrophilic seal compatible with the installed CIPP, shall be applied at manhole/wall interface, if specified, in accordance with the CIPP System manufacturer's recommendations.
- B. Existing services shall be internally or externally reconnected unless indicated otherwise in the contract documents
- C. Reconstructions of existing services shall be made after the CIPP has been installed, fully cured, and cooled down. It is the Contractor's responsibility to make sure that all active service connections are reconnected. If verification of active service connections requires techniques beyond standard mainline CCTV then a separate bid item shall be included.

Verification of active services can be completed using many options such as dye testing, CCTV via lateral launching from the main, connection records from the Owner or other means. Methods requiring the Contractor to extend resources beyond mainline CCTV should be separate bid items.

- D. External reconstructions are to be made with a tee fitting or other approved method in accordance with CIPP System manufacturer's recommendations. Saddle connections shall be seated and sealed to the new CIPP using grout or resin compatible with the CIPP.
- E. A CCTV camera and remote cutting tool shall be used for internal reconstructions. The machined opening shall be at least 90 percent of the service connection opening area and the bottom of both openings must match. The opening shall not be more than 100 percent of the service connection opening. The edges of the opening shall not have

pipe fragments or CIPP fragments which may obstruct flow or snag debris. In all cases the invert of the service connection shall be cut flush with the invert entering the mainline.

- F. If service reinstatements result in openings that are greater than 100 percent of the service connection opening, the Contractor shall install a CIPP type repair, sufficiently in size to completely cover the over-cut service connection. No additional compensation will be paid for the repair of over-cut service connections.
- G. Coupons or fragments of CIPP material resulting from service tap cutting shall be collected at the next manhole downstream of the pipe rehabilitation operation prior to leaving the site. Coupons may not be allowed to pass through the system.
- H. Compensation shall be at the actual number of services reconnected using either internal or external means as contained in the Proposal. The unit price bid per service line reconnected shall include all materials, labor, equipment and supplies necessary to complete the work as required in these specifications.

3.7 TESTING OF INSTALLED CIPP

CIPP mechanical properties should be verified through field sampling and independent testing. Samples shall be taken from the CIPP section installed and should be properly marked and transmitted to an independent testing laboratory or obtained from the project site by a laboratory representing the Owner. Test results should be transmitted from the laboratory to the Owner's representative. Sampling should be in accordance with ASTM F1216, ASTM F1743, or ASTM F2019 as applicable, and a chain of custody should be strictly maintained. Restrained samples can be used for sewers of 18" diameter or less. Plate samples are used for pipelines larger than 18" diameter. Samples should be acquired as directed and specified by the Owner or the Contract documents.

- A. The mechanical properties and thickness of the installed CIPP shall be verified through field sampling and laboratory testing. All materials for testing shall be furnished by the Contractor to the Owner for testing. All materials testing shall be performed at the Owner's expense by an independent third-party laboratory selected by the Owner as recommended by the CIPP manufacturer. All tests shall be in accordance with applicable ASTM test methods to confirm compliance with the requirements specified in these contract documents, or as submitted in the PWS. Tubes constructed of fiberglass and cured by light (i.e., photoinitiated reaction) shall be tested in accordance with Appendix X2 of ASTM F2019.
- B. The Contractor shall provide samples for testing to the Owner from the actual installed CIPP. Samples shall be provided from each section of CIPP installed or as required by the Owner. The sample shall be cut from a section of cured CIPP that has been inverted or pulled through a like diameter pipe which has been held in place by a

suitable heat sink, such as sandbags. All curing, cutting and identification of samples will be witnessed by the Owner and transmitted by the Owner's representative as specified, and sent to the testing laboratory. Flat plate samples can be taken on pipelines greater than 18 inches in diameter, if specified. Identification on the samples shall include markings indicating the direction of reinforcement when used in tube construction and shall be standard chain of custody markings.

- C. The laboratory results shall identify the test sample location as referenced to the nearest manhole and station. Final payment for the project shall be withheld pending receipt and approval of the test results. If properties tested do not meet the minimum mechanical and thickness requirements, the CIPP shall be repaired or replaced by the Contractor unless the actual mechanical properties and the thickness of the sample tested meet the design requirements as required in the contract.

Chemical resistance is a qualification test where CIPP samples tested should be of the tube and resin proposed for the actual construction. For municipal applications, a certification is typically submitted from the manufacturer verifying that the chemical resistance meets the contract requirements. For industrial installations, the chemical resistance of the resin installed must be tested to meet the corrosion resistance requirements of the pipeline being rehabilitated.

- D. Chemical resistance - The CIPP system installed shall meet the chemical resistance requirements of the relevant ASTM standard(s) F1216, ~~or~~ ASTM F1743, ASTM D5813 (section 6.4.1), or ASTM F2019. CIPP samples tested shall be of the tube and the specific resin proposed for actual construction. It is required that CIPP samples without plastic coating meet these chemical testing requirements. A certification may be submitted, by the Contractor, from the manufacturer verifying that the chemical resistance of the CIPP meets the contract requirements.
- E. Hydraulic Capacity - The installed CIPP shall, at a minimum, be equal to the full flow capacity of the original pipe before rehabilitation. Calculated capacities may be derived using a commonly accepted roughness coefficient for the existing pipe material taking into consideration its age and condition.
- F. The installed CIPP thickness shall be measured for each line section installed as per the ASTM requirements specified. If the CIPP thickness does not meet that specified in the contract and submitted as the approved design by the Contractor, then the CIPP shall be repaired or removed unless the tested mechanical properties and the thickness of the sample tested meet the design requirements as required in the contract. The CIPP thickness shall have tolerance of minus 5%. In worker-entry size piping, where sampling is by flat plate, a quality-based approach using the approved quality plan will be used to accept installed thickness (see discussion in following text box). If the plate sample does not meet the required mechanical property values, or if quality checks are deficient, it may be necessary for the Contractor to remove a core sample from the CIPP 12 o'clock position to check thickness. The openings produced from core samples shall be repaired in accordance with manufacturer's recommended

procedures.

For small diameter CIPP of 18" inch diameter or less, the restrained sample can be measured for thickness. In sewers larger than 18-inch diameter the flat plate sample can be tested for thickness, but a flat plate can be constructed in any thickness. The thickness can be measured in a manhole once the CIPP ends are cut, but this may result in a low measurement due to resin loss and thinning. A quality-based approach can be used where it is determined that if all the quality checks are met, the likelihood of the CIPP installed thickness meeting the required minimum installed thickness is good. For example, if the dry tube is the correct thickness, the correct type and amount of resin is added during wet-out, and the correct pressures, temperatures and procedures are used during installation and cure, the installed thickness should meet the design minimum thickness. If the plate sample does not meet the required physical property values, or if any quality checks are deficient, it may be necessary to remove a core sample from the CIPP at the 12:00 o'clock position to check thickness. The core hole shall be repaired as recommended by the manufacturer.

- G. All costs to the Contractor associated with providing cured CIPP samples for testing shall be included in the Lump Sum price bid for Mobilization. Payment for all testing by a laboratory will be paid for by the Owner directly to the laboratory under the lump sum Reserve for Testing item in the Bid Proposal.

3.8 FINAL ACCEPTANCE

Sample testing and repairs to the CIPP should be completed. Test results must have been received from the independent laboratory and meet the contract specified requirements prior to final acceptance of the installed CIPP.

- A. CIPP sample testing and repairs to the installed CIPP, as applicable, shall be completed before final acceptance, meeting the requirements of these specifications, and documented in written form.

Prior to conducting the final CCTV, the Contractor should thoroughly clean the newly installed CIPP. Sewage flow in the line should be minimized, and standing water in sags should be cleared. The CCTV visual quality of the final inspection shall be as specified in the contract. If the quality does not meet the specified requirements, the Contractor shall re-CCTV those section that are unacceptable.

- B. The Contractor shall perform a closed-circuit television inspection in the presence of the Owner after installation of the CIPP and reconnection of the side sewers per PACP requirements. Conventional pan-and-tilt TV camera or sidewall scanning technology, as approved by Owner, shall be used. The finished CIPP shall be continuous over the entire length of the installation and shall be free of significant visual defects, damage, lifts, holes, leaks and other defects that are not a reflection of the existing pipe condition. Unedited digital documentation of the inspection shall be provided to the

Owner within ten (10) working days of the CIPP installation. The data shall note the inspection date, location of all reconnected side sewers, debris, as well as defects in the CIPP, including, but not limited to, gouges, cracks, bumps, or bulges. If post installation inspection documentation is not submitted within ten (10) working days of the CIPP installation, the Owner may, at its discretion, suspend further installation of CIPP until the post-installation documentation is submitted. As a result of this suspension, no additional working days will be added to the contract, nor will adjustment be made for increase in cost. Immediately prior to conducting the CCTV inspection, the Contractor shall clean the newly installed CIPP removing debris and build-up that may have accumulated at no additional cost to the Owner.

Final CCTV inspection should be performed using water jets to eliminate standing water in sags and bellies while the line is being televised.

If required by the Owner in the specifications, leakage can be determined through visual inspection (water or air installations), hydrostatic testing (water installations), air testing (air installations) or infiltration testing (water or air installations). For small diameter sewers installed with air pressure (light cure or steam cure), it does not make sense to do hydrostatic (exfiltration) testing for leakage. This leaves visual inspection or air testing as viable alternatives.

For large diameter sewers, visual inspection for leakage is the most common method. Air and hydrostatic testing should not be performed for sewers greater than 36" diameter because of worker safety. Any unacceptable leakage through the CIPP wall should be repaired as required in the contract documents or agreed to by the owner.

- C. If required by the Owner in the specifications, and if the pipe diameter is less than or equal to 36", the CIPP shall be tested for leakage using the water exfiltration test (ASTM F1216 8.2) or a low pressure air test (refer to Appendix A). Testing is limited to pipe lengths with no reinstated service laterals and could delay service lateral reinstatement. Water exfiltration or air testing is not recommended in pipe diameters exceeding 36" diameter. In these cases, a visual inspection for leakage shall be performed, if specified.

Any unacceptable leakage through the CIPP wall should be repaired as required in the specifications or agreed to by the owner.

Not all CIPP line segments can be air tested because of end configurations in the manhole, shape of the CIPP and CIPP irregularities. It is recommended that only a set percentage of the line segments in any one project be tested in lieu of testing each line segment.

Low pressure air testing can be a dangerous operation. It is imperative that all safety protocols for plug operation & maintenance and air testing be followed, including proper blocking/bracing of plugs during the air test and limiting air tests to a maximum diameter of 36 inches.

- D. Bypass pumping or plugging from the upstream manhole shall be utilized to minimize sewage from entering the line during the inspection. In the case of bellies in the line, the pipe shall be cleared of standing water to provide continuous visibility during the inspection.

3.9 TYPICAL BID ITEMS

Additional items such as pre-liner and flowable backfill can be added to specific contracts requiring these items.

- A. Mobilization – Lump Sum - Includes all PWS information, submittals, safety plan, as-built drawings, testing samples, mobilization/demobilization of labor, equipment and materials to the project site. Generally limited to 5% of the total amount bid for the project.
- B. Pre-Installation CCTV Inspection – Per linear foot - Includes pre-cleaning and post cleaning CCTV for Owner review. Does not include CCTV inspection just prior to CIPP installation. All inspections will be performed by PACP trained and certified personnel.
- C. Dye Testing of Service Connections – Per each - Includes dye testing and documentation of existing service connection on each pipe length to be lined.
- D. Point Repairs – Per each or by Lump Sum Contingency - Includes excavation and restoration of a section or sections of pipe that are beyond rehabilitation using CIPP. Note: Point repair items shall be categorized by pipe size, a minimum length of excavation and depth category of excavation to be paid for in the Proposal. If point repairs are not identified in the contract documents, payment shall be on a contingency basis.
- E. Standard Pipe cleaning – Per linear foot for each pipe size category – including all labor, equipment, materials and cost of material disposal.
- F. Heavy Pipe Cleaning – Per linear foot for each pipe category – including all labor, equipment, materials and cost of material disposal.
- G. Preliner Installation – per linear foot installed by size category. Includes all labor, equipment and materials required.
- H. CIPP Installation – Per linear foot for each pipe size category - Includes all labor,

equipment and materials required for the complete installation of a CIPP.

- I. Flowable Fill – per cu. yd. of material installed and documented including all labor, equipment and materials required for the complete backfilling of soil voids.
- J. Traffic Control – Lump Sum – Includes all labor, equipment and materials required to implement a traffic control plan for the entire project and shall include all costs associated with sub-contracted traffic control specialists.
- K. Sewage Bypass – Lump Sum – Includes all labor, equipment and materials required to implement a flow bypass plan for the entire project, including the cost of all sub-contracted flow bypass specialists.
- L. Service Reconnections – Per each – Includes reconnecting existing live sewer service connections to the installed CIPP. Owner shall review and verify those connections that are not live and will be left unopened.
- M. Service connection sealing – Per each – Includes sealing the interface between the installed CIPP and the host pipe at the location of the service connection.
- N. Manhole/Wall Interface Sealing – Per each – Includes sealing the interface between the installed CIPP and the manhole wall.
- O. Post Construction CCTV Inspection - Per linear foot - Includes post lining CCTV for submission to the Owner. All inspections will be performed by PACP trained and certified personnel.
- P. Reserve for Testing – Lump Sum Reserve – For Owners use to include testing required as directed by the Owner, under this contract, by an independent laboratory. (The amount will be set by the Owner in the Bid Proposal)

****END OF SECTION****

Appendix A: Air Testing of CIPP

Pressure gauges used for this test shall have a minimum division of 0.1 psi and an accuracy of 0.0625 psi.

Test Procedure:

1. The tested pipe may be wet or dry.
2. The minimum test pressure should equal 3.5 psi plus 0.433 psi for each foot of average water or groundwater depth over the crown of the pipe. The maximum test pressure shall be 6 psi.
3. Slowly add air to the section of pipe being tested until the internal air pressure is raised to 4 psi greater than the average back pressure due to water or groundwater. The maximum air pressure shall be 6 psi.
4. Once the test pressure is reached, allow a period of time for the air temperature to stabilize. The stabilization period can vary from a few minutes to an hour or more dependent upon the temperature of the air and CIPP under test. Add air to maintain pressure.
5. After the temperature stabilization period, disconnect the air supply.
6. Record the time in seconds required for the air pressure to drop from 3.5 to 2.5 psi greater than the average back pressure due to water or groundwater.

Acceptance Criteria:

The tested section is acceptable if the time recorded is not less than the time in seconds (T):

$$T = K/C$$

Where:

K = the sum of the computations ($0.011d^2L$) for each size of CIPP and its length in the section

C = the sum of the computations ($0.0003882 dL$) for each size of CIPP and its length in the section; the minimum value for C = 1

d = inside diameter of CIPP in inches

L = length of CIPP in feet

If the tested section fails the air test (time recorded is less than T), check all connections of the test apparatus with soapy water for leaks. Complete another stabilization period (# 4 above) and retest. If the tested section fails again but the results are better (time recorded is still less than T but closer), the problem may be temperature stabilization or re-rounding or expansion of the CIPP. Repeat the stabilization/test cycle if results continue to improve until the section passes. If after repeated test/stabilization cycles the results are not improving, there is most likely a leak in the CIPP or the test apparatus.

If it is determined that there is a leak in the CIPP test section, then a visual test will be performed to locate the leak and repair it, if possible. Repairs will be in accordance with manufacturer's recommendations. Once repaired, the section should be retested.

Not all CIPP line segments can be air tested because of end configurations in the manhole, shape of the CIPP and CIPP irregularities such as wrinkles. It is recommended that only a set percentage (typically 10%) of the line segments in any one project be tested in lieu of testing each line segment.

Low pressure air testing can be a dangerous operation. It is imperative that all safety protocols for plug operation & maintenance and air testing be followed, including proper blocking/bracing of plugs during the air test and limiting air tests to a maximum diameter of 36 inches.

Table 1: Example Air Test Chart for Gravity Sewers

*Adapted from "Oregon Standard Specifications for Construction, 2015, Section 00445.72 Pipe Testing, pp. 330-331"

Table 1: Example Air Test Chart for Gravity Sewers

Example Air Test Chart for Gravity Sewers																		
Minimum Acceptance Time for Pressure Drop from 3.5 to 2.5 psi																		
Adapted from "Oregon Standard Specifications for Construction" (2015)																		
Diameter	6-inch			8-inch			10-inch			12-inch			18-inch			24-inch		
Length (ft.)	C	K	Minimum Time	C	K	Minimum Time	C	K	Minimum Time	C	K	Minimum Time	C	K	Minimum Time	C	K	Minimum Time
			Min.-Sec.			Min.-Sec.			Min.-Sec.			Min.-Sec.			Min.-Sec.			Min.-Sec.
100	1.00	35	0'-35"	1.00	64	1'-02"	1.00	100	1'-40"	1.00	146	2'-26"	1.00	329	5'-29"	1.00	585	9'-45"
150	1.00	53	0'-53"	1.00	93	1'-33"	1.00	150	2'-30"	1.00	219	3'-39"	1.01	493	8'-10"	1.34	877	10'-53"
200	1.00	70	1'-10"	1.00	125	2'-05"	1.00	200	3'-20"	1.00	292	4'-52"	1.34	658	8'-10"	1.79	1169	10'-53"
250	1.00	88	1'-28"	1.00	156	2'-36"	1.00	250	4'-10"	1.12	365	5'-27"	1.68	822	8'-10"	2.24	1462	10'-53"
300	1.00	105	1'-45"	1.00	187	3'-07"	1.11	300	4'-30"	1.34	439	5'-27"	2.01	987	8'-10"	2.68	1754	10'-53"
350	1.00	123	2'-03"	1.02	218	3'-33"	1.29	349	4'-30"	1.57	512	5'-27"	2.35	1151	8'-10"	3.13	2046	10'-53"
400	1.00	140	2'-20"	1.17	249	3'-33"	1.48	399	4'-30"	1.79	585	5'-27"	2.68	1316	8'-10"	3.58	2339	10'-53"
450	1.00	158	2'-38"	1.31	280	3'-33"	1.66	449	4'-30"	2.01	658	5'-27"	3.02	1480	8'-10"	4.03	2631	10'-53"
500	1.10	175	2'-40"	1.46	312	3'-33"	1.85	499	4'-30"	2.24	731	5'-27"	3.36	1644	8'-10"	4.47	2923	10'-53"
550	1.21	193	2'-40"	1.61	343	3'-33"	2.03	549	4'-30"	2.46	804	5'-27"	3.69	1809	8'-10"	4.92	3216	10'-53"
600	1.31	210	2'-40"	1.75	374	3'-33"	2.22	599	4'-30"	2.68	877	5'-27"	4.03	1973	8'-10"	5.37	3508	10'-53"
650	1.42	228	2'-40"	1.90	405	3'-33"	2.40	649	4'-30"	2.91	950	5'-27"	4.36	2138	8'-10"	5.82	3801	10'-53"
700	1.53	245	2'-40"	2.05	436	3'-33"	2.59	699	4'-30"	3.13	1023	5'-27"	4.70	2302	8'-10"	6.26	4093	10'-53"

Notes:	1. $C = (0.0003882)dL$	4. If C is less than 1 use C = 1
	2. $K = (0.011)d^2L$	5. For project calculated minimum times, use actual inside diameter of CIPP
	3. $T_{(Sec.)} = (K/C)$	6. Calculations shown are for 4.5 mm CIPP for 6", 6 mm for 8", 10" & 12", 9 mm for 18" and 12 mm for 24"
	7. If $C > 1$, $T_{(Sec.)} = 28.34d$	

GENERAL CONDITIONS

TABLE OF CONTENTS

GENERAL CONDITIONS

1. DEFINITIONS	1
2. EXECUTION OF CONTRACT	6
2.1. NOTICE TO PROCEED	6
2.2. CONTRACT BONDS	6
2.3. INSURANCE	7
2.4. CONTRACTOR'S LIABILITY NOT LIMITED BY INSURANCE	7
3. CONTROL OF THE WORK	7
3.1. AUTHORITY OF THE ENGINEER	7
3.2. SUPERVISION BY CONTRACTOR	8
3.3. CONTRACTING AND ASSIGNMENT	9
4. LEGAL RELATIONS AND RESPONSIBILITIES	9
4.1. LAWS TO BE OBSERVED	9
4.2. GENERAL INDEMNIFICATION	13
4.3. JOINT AND SEVERAL LIABILITY	15
4.4. RESPONSIBILITY FOR LOSS, DAMAGE OR INJURY	15
4.5. OWNERSHIP OF PLANS, SPECIFICATIONS, SHOP DRAWINGS	15
4.6. PRESERVATION OF PROPERTY	16
4.7. PERSONAL LIABILITY	17
4.8. WARRANTY OF TITLE	17
4.9. PROPERTY RIGHTS IN MATERIAL	18
4.10. TERMINATION FOR DEFAULT	18
4.11. TERMINATION FOR CONVENIENCE	20
4.12. NOTICE AND SERVICE THEREOF	22
4.13. PARTIAL INVALIDITY	22
4.14. WAIVER OF RIGHTS	23
4.15. TAXES	23
4.16. ASSIGNMENT OF ANTITRUST ACTIONS	23
4.17. SUBCONTRACTING	23
4.18. FLOW-DOWN REQUIREMENTS	23

4.19.	ASSIGNMENT.....	24
4.20.	WARRANTY (CONTRACTOR’S GUARANTEE).....	25
4.21.	SAFETY PRECAUTIONS AND EMERGENCIES.....	26
5.	SCOPE OF WORK.....	28
5.1.	GENERAL.....	28
5.2.	CONSTRUCTION PROCEDURES AND PROTECTION.....	28
5.3.	ERRORS AND OMISSIONS	31
5.4.	REQUEST FOR CHANGE (CHANGES AT CONTRACTOR’S REQUEST).....	32
5.4.	OWNER INITIATED CHANGES.....	35
5.5.	CLAIMS.....	37
5.6.	DISPUTES.....	38
6.	PROSECUTION AND PROGRESS OF THE WORK.....	39
6.1.	PROGRESS OF THE WORK.....	39
6.2.	TEMPORARY SUSPENSION OF WORK.....	39
6.3.	EXTENSION OF TIME FOR DELAY	39
6.4.	LABOR COMPETENCY	41
6.5.	USE PRIOR TO FINAL COMPLETION (BENEFICIAL OCCUPANCY).....	41
6.6.	SUBSTANTIAL COMPLETION.....	42
6.7.	FINAL COMPLETION AND FINAL ACCEPTANCE	43
6.8.	TIME OF COMPLETION.....	44
7.	PAYMENT FOR WORK.....	45
7.1.	PAYMENT - GENERAL	45
7.2.	PAYMENT – APPLICATIONS FOR PAYMENT	46
7.3.	CONTRACT PRICE ADJUSTMENTS AND PAYMENTS ...	47
7.4.	INCREASE OR DECREASE IN UNIT QUANTITIES	54
7.5.	SUSPENSION OF PAYMENTS	54
7.6.	MCSD’S RIGHT TO WITHHOLD CERTAIN AMOUNTS AND MAKE APPLICATION THEREOF.....	54
7.7.	STOP PAYMENT NOTICES.....	55
7.8.	AUDIT ACCESS TO RECORDS	55
7.9.	RETAINED FUNDS; SUBSTITUTION OF SECURITIES....	57

7.10. FINAL PAYMENT.....	57
8. MISCELLANEOUS	58
8.1. GOVERNING LAW.....	58

GENERAL CONDITIONS

1. DEFINITIONS

The following definitions are used in the Specifications or other Contract Documents. Their intent and meaning shall be as follows:

As-Built Drawings – A copy of the Plans used by the CONTRACTOR to record changes to the Work as specified in the General Requirements.

Beneficial Occupancy – Intended use of a building, system, structure, or facility by MCSD prior to Final Completion.

Bid – A form, or forms, completed in their entirety stating the Bidder's offer to both furnish all materials and to perform all Work required under the Contract. Bid also includes a proposal submitted by CONTRACTOR to perform all required Work.

Board – Board of Directors of the Midway City Sanitary District (MCSD). Where authority has been properly delegated to him, the Board may act through the General Manager

Bond – Performance Bond Public Works (Performance Bond), or Payment Bond Public Works (Payment Bond) or other instrument of security.

Business Day – A day on which MCSD offices are open for regular business, Monday through Friday between the hours of 8:00 A.M. to 4:30 P.M. (Pacific Time Zone) unless otherwise specified, and excluding MCSD Holidays.

Change Order – A written order by the ENGINEER, made bilaterally by MCSD and CONTRACTOR or unilaterally by MCSD, which covers alterations, changes, additions, or deletions to the Contract Documents or the Work in any manner which are necessary for the proper completion of the Work and which may result in adjustments to the Contract Price, period of performance, or both.

Claim – A written statement by the CONTRACTOR requesting additional time and/or money from MCSD arising out of acts or omissions of MCSD and/or differing conditions during the performance of the Contract which the CONTRACTOR could not have reasonably anticipated at the time of entering into the Contract, and which is submitted in response to MCSD's rejection of, or failure to approve, CONTRACTOR's Request for Change, or otherwise issue a Change Order modifying the Contract, adjusting the Contract Price and/or period of performance in a manner consistent with that which the CONTRACTOR believes is appropriate. The Claim shall be submitted in the manner and in the time consistent with the requirements set forth in these General Conditions.

Code – Codes of the State of California as well as any other federal or local law, statute, ordinance, rule or regulation.

Construction Schedule – The CONTRACTOR’s accepted Baseline Construction Schedule as it evolves through periodic updates that record actual progress of the Work to completion, when it shall show the “as-built” record of the CONTRACTOR’s work plan as executed.

CONSULTANT – Any CONSULTANT retained by MCSD or its (sub) consultant(s) who provides design or construction phase services for support of this Project.

Contract / Contract Documents – The following documents constitute a part of and comprise the Contract Documents: Agreement, CONTRACTOR’s Bid, Performance Bond Public Works, Payment Bond Public Works, insurance certificates and endorsements, Plans and Specifications, General Conditions, plan clarifications, and Supplemental Agreements, including Change Orders issued after Contract award.

Contract Duration / Time of Completion – The period of performance provided for in the Agreement, and as amended via Change Orders.

Contract Milestone / Milestone – A significant performance point in the Work, as provided for in the Contract Documents.

CONTRACTOR – The individual, partnership, joint venture, corporation, or other combination thereof, identified as such in the Contract, and referred to throughout the Contract Documents as if singular in number and who directly contracts with MCSD. The term “CONTRACTOR” means the CONTRACTOR or its authorized representative.

Contract Price – The total amount of money for which the Contract is awarded, as modified by any Change Orders.

Contract Unit Price – The amount stated in the CONTRACTOR’s Bid for a single unit of an element of the Work.

Critical Path – A continuous sequence of schedule network activities with the least amount of total float, ending at a Contract Milestone.

Days – Unless otherwise specifically stated, the term “days” will be understood to mean consecutive calendar days.

Drawings – See Plans.

DISTRICT – Midway City Sanitary District.

DISTRICT Holidays – MCSD recognizes the following holidays on which its offices are closed for regular business: New Year’s Day, Washington’s Birthday, Memorial Day, Independence Day, Labor Day, Veteran’s Day, Thanksgiving Day, the day after Thanksgiving, Christmas Eve, and Christmas Day. Holidays that occur on Saturdays and Sundays will be observed on the preceding Fridays and the following Mondays, respectively. MCSD reserves the right to recognize additional holidays without prior notice.

ENGINEER –The District Engineer of MCSD or MCSD’s designee.

Extra Work – New or unforeseen Work, or added Work of a different character or function and for which no basis for payment is prescribed in the Contract Documents; or that involves revisions of the details of the Work in such manner as to render inequitable payment under items upon which the CONTRACTOR bid in its Bid; or that Work to be done under “stipulated prices” as given in the Schedule of Prices.

Final Acceptance – Action taken by MCSD Board of Directors accepting the Work as fully completed.

Final Completion / Contract Completion / Completion / Completion Date – The Contract Milestone recognized through action taken by the ENGINEER certifying that the Work is fully completed under the Contract Documents prior to MCSD’s acceptance of the Work as fully completed.

Float – The flexibility that an activity has against the critical path.

Fragment– A fragment of the schedule network that typically illustrates a particular sequence of activities for thorough analysis.

General Conditions – Legal and contractual instructions to the CONTRACTOR setting forth both the CONTRACTOR and MCSD responsibilities for business related activities pertaining to the Contract. The term “General Conditions” used in the Specifications shall be interpreted to refer to the General Conditions of the Contract Documents.

General Manager – The individual designated by MCSD as its Chief Executive Officer and agent.

General Requirements – Legal and contractual instructions to the CONTRACTOR setting forth both the CONTRACTOR and MCSD responsibilities for technical aspects of the Work indicated under the Contract. The term “General Requirements” used in the Specifications shall be interpreted to refer to the General Requirements of the Contract Documents.

INSPECTOR – The individual(s) designated by the ENGINEER as the field Project representative with delegated authority to enforce the requirements of the Contract Documents, subject to the approval of the General Manager.

Law – Any federal, state or local law, statute, ordinance, rule, regulation or code.

Legal Address of CONTRACTOR – The address given on the CONTRACTOR’s Bid shall be the legal address of the CONTRACTOR and is the designated place to which all notices, letters or other communications to the CONTRACTOR shall be mailed or delivered.

MCSD – Midway City Sanitary District.

Notice to Proceed -- A written notice given by MCSD to the CONTRACTOR fixing the date on which the time for performance under the Contract will commence.

MCSD – Midway City Sanitary District.

Operational Acceptance – Written notification by the ENGINEER accepting the Work as operationally complete. Used for the purpose of placing equipment or facilities in service before all of the Contract Work is completed.

or equal / Or Equal / OR EQUAL – Any product, equipment, material, thing, or service which is proposed by the CONTRACTOR for use in the Work, which is equal to or better than, and is as suitable as the product, material, equipment, thing or service specified in the Contract Documents as to function, performance, reliability, quality, and general configuration.

OWNER – Midway City Sanitary District.

Payment Bond Public Works – A bond required from a CONTRACTOR to secure payment to Subcontractors, laborers, mechanics and Suppliers employed on the Work of the Contract.

Performance Bond Public Works – A bond required from a CONTRACTOR at the time of execution of a Contract which guarantees faithful performance of the Contract by the CONTRACTOR.

Plans – The part of the Contract Documents consisting of the plans, profiles, typical and general cross-sections, working drawings, or exact reproductions thereof, which show the location, character, dimensions and details of the Work to be done (if any).

Project(s) – The entire scope of Work covered by all Contract Documents.

Proposal – A standard form supplied by MCSD as tear-out sheets, which when completed in its entirety and executed, shall constitute a Bid Submittal.

Record Drawings – Construction drawings from completed projects maintained by MCSD as a record of how facilities were actually constructed. These are generally created from the original plans, addendum and Change Order drawings, and the CONTRACTOR's as-built copy of the construction plans.

Request for Change – A written request by the CONTRACTOR to MCSD for the issuance of a Change Order.

Schedule of Prices - A list of Bid Item(s) in the Bid or Proposal including the item number, approximate quantities, item descriptions, total price per item and total amount of Bid.

Specifications – Elements of the Contract Documents and revisions which describe the commercial, legal, technical and non-technical requirements of the Project. Specifications

include but are not limited to Project Requirements, Provisions, General Conditions, General Requirements, Supplementary Conditions, Technical Specifications, and all revisions made to the Specifications including Addenda, Notice to Bidders, and Change Orders, signed by the ENGINEER and authorized by the Board.

Standard Plans / Standard Drawings – Details of standard structures, devices or instructions referred to on the Plans or in the Specifications by title or number and issued by MCSD.

Standard Specifications for Public Works Construction – The latest edition of Standard Specifications for Public Works Construction (“Green Book”) as written and promulgated by the Public Works Standards, Inc.

Subcontractor – One who is licensed pursuant to California Business and Professions Code, Section 7000 et. seq., and who contracts directly with the prime CONTRACTOR or with another Subcontractor to perform some part of the Work. A Subcontractor does not have any direct contract with MCSD related to the Work.

Supplemental Agreements – Written agreements between MCSD and the CONTRACTOR, covering schedules, drawings, instructions, alterations, amendments or extensions to the Contract and including Contract Change Orders.

Supplier – An individual, organization, or firm who is not required for the purposes of the Work to be licensed pursuant to California Business and Professions Code as a CONTRACTOR or Subcontractor, within the meanings of those terms as defined hereinabove, who provides equipment and/or materials for the Work to the CONTRACTOR or a Subcontractor, including that fabricated to a special design, but who does not perform labor at the site except for labor or labor supervision required by some manufacturers as part of their equipment installation for warranty or other purposes or for operation of rented equipment, and only to the extent such labor or labor supervision is excepted from licensing requirements under the California Business and Professions Code, including but not limited to Section 7040 et seq. The term “supplier” also includes fabricator, manufacturer, or vendor.

Surety or Sureties – The bondsmen or party or parties who guarantee the fulfillment of the Contract, or a portion of the Contract, by Bond and whose signatures are affixed to the Bond.

Terms – The terms “Approved”, “Directed”, “Satisfactory”, “Accepted”, “Acceptable”, “Proper”, “Required”, “Necessary”, and “Or Equal” mean as approved, directed, satisfactory, accepted, acceptable, proper, required, necessary, and or equal, in the opinion of the ENGINEER.

Total Float – The amount of time that the actual start and finish of an activity can be delayed along a given network path without delaying the Contract Completion date.

Trade Names – Where a certain product is called by its Trade Name, it is intended as a guide for type and quality.

Typical Details – Details of standard structures, devices or instructions referred to on the Plans and Specifications by title or number and developed by the CONSULTANT.

Unavoidable Delay – An interruption of the Work beyond the control of the CONTRACTOR and which interruption the CONTRACTOR could not have avoided by the exercise of care, prudence, foresight, diligence and mitigation.

Work – All the Work specified in the Contract Documents necessary to complete the requirements of the Contract, including the furnishing of all labor and materials. Also, the completed construction or parts thereof required to be provided under the Contract Documents, including all materials, equipment, and supplies incorporated or to be incorporated in the construction.

2. EXECUTION OF CONTRACT

2.1. NOTICE TO PROCEED

Upon receipt of all properly executed Contract Documents from CONTRACTOR, MCSD shall execute all documents as necessary, establish the effective date of the Contract, and MCSD shall issue a Notice to Proceed, unless the ENGINEER determines that good cause exists to delay the issuance. In such case, MCSD may delay issuance of the Notice to Proceed. Said Notice to Proceed shall be forwarded to the CONTRACTOR by mail or by any other means which shall provide confirmation of a date and time receipt acknowledgment, including but not limited to electronic telecommunication. The time required for completion of the Contract shall begin upon the effective date of the Notice to Proceed.

2.2. CONTRACT BONDS

Before or concurrently with final execution of the Contract, the CONTRACTOR shall furnish two Surety Bonds, on the forms provided by MCSD, as part of the Contract Documents. Each Bond shall have good and sufficient Sureties subject to the approval of MCSD. The first shall ensure the payment of all labor performed and material used in the Work, and the second shall ensure the faithful performance of the Contract.

The Payment Bond Public Works (Labor and Material Bond) shall be in an amount equal to one hundred percent (100%) of the Bid price, so conditioned as to inure to the benefit of persons furnishing materials to the CONTRACTOR for and/or performing labor upon the Work of the CONTRACTOR. This Bond shall be maintained by the CONTRACTOR in full force and effect until the Work has been completed and accepted by MCSD and all claims for labor and material have been paid. As changes to the Contract occur via approved Change Orders, the CONTRACTOR shall assure that the amount of the Bond is adjusted to maintain 100% of the Contract Price.

The Bond for faithful performance (Performance Bond Public Works) shall be an amount equal to one hundred percent (100%) of the Total Amount of Bid price, so conditioned as to insure

the faithful performance by the CONTRACTOR of all Work within the time limit prescribed, and in a manner that is satisfactory and acceptable to MCSD. This Bond shall be maintained by the CONTRACTOR in full force and effect during the performance of the Work of the Contract and until the Work has been accepted by MCSD. This Bond shall also apply to the use of patented articles, materials or processes; to guarantee the payment of all stop payment notice claimants, and shall assure faithful performance of the one (1) year warranty from the date of Final Acceptance by MCSD and any extensions to said warranty period as provided by the Contract Documents. As changes to the Contract occur via approved Change Orders, the CONTRACTOR shall assure that the amount of the Bond is adjusted to maintain the 100% of the Contract Price.

Should any Surety or Sureties ever be deemed unsatisfactory by MCSD, the CONTRACTOR shall be notified to that effect, and the CONTRACTOR shall forthwith substitute a new Surety or Sureties satisfactory to MCSD. No further payment shall be deemed due or will be made under the Contract until the new Sureties shall qualify and be accepted by the Board of Directors. For Surety companies to be acceptable to MCSD they must be admitted to do business as a Surety in and have an agent for service of process in California.

2.3. INSURANCE

The CONTRACTOR shall purchase and maintain insurance, in amounts equal to the requirements in the form and manner provided for in the Contract Documents.

2.4. CONTRACTOR'S LIABILITY NOT LIMITED BY INSURANCE

Nothing contained in the insurance requirements is to be construed as limiting the liability of the CONTRACTOR or the CONTRACTOR's Sureties.

3. CONTROL OF THE WORK

3.1. AUTHORITY OF THE ENGINEER

The ENGINEER serves as the agent of MCSD and will observe the accomplishment of the Work in accordance with the provisions of the Contract. The ENGINEER will decide any and all questions which may arise as to the interpretations of the Contract Documents, as to the quality and acceptability of materials furnished and Work performed, as to the manner of performance, and as to the rate of progress of the Work. All questions as to the acceptable performance of the Contract on the part of the CONTRACTOR shall be decided by the ENGINEER.

It shall be the duty of the CONTRACTOR to call the ENGINEER's attention to apparent errors and omissions in the Plans and Specifications. The ENGINEER may, by appropriate written instructions, correct errors and omissions, which instructions shall be as binding upon the CONTRACTOR as though contained in the original Contract Documents. The ENGINEER

shall have authority to make minor changes in the Work not involving extra or lesser cost, and not inconsistent with the intent of the Contract Documents.

All instructions, rulings, and decisions of the ENGINEER shall be in writing, and shall be final and binding on the CONTRACTOR unless formal written objection is made as specified herein.

It is expressly agreed that the ENGINEER shall not have the power to waive any of the obligations of the Contract Documents for the furnishing by the CONTRACTOR of good and suitable material, and for performing the Work as herein described. Failure or omission on the part of the ENGINEER to reject defective or inferior Work or materials, or the ENGINEER's release of the CONTRACTOR from obligations to remedy the defective or inferior Work, shall not imply acceptance of the Work. Upon discovery of said defective Work, the CONTRACTOR shall immediately tear out, remove, and properly replace the defective Work without additional compensation. Neither shall such failure or omission, nor any acceptance by the ENGINEER, or by the Board be construed as relieving the responsibilities of the CONTRACTOR or its Sureties, for a sum of money as may be needed to remove and replace, or to repair, any or all Work or materials which is found to be defective or inferior. In such instance, in lieu of the recovery of said sum of money, MCSD may permit the CONTRACTOR to perform, at the CONTRACTOR's own expense, the work of removing and replacing or repairing Work or materials found to be defective or inferior.

The Board shall have the final authority in all matters affecting the Work. Within the scope of the Contract Documents, the ENGINEER shall have the authority to enforce compliance with the Contract Documents. The CONTRACTOR shall promptly comply with all instructions from the ENGINEER which are made in accordance with the Contract Documents.

In all matters relating to acceptability of construction materials and equipment, execution and progress of Work, percentage of completion, the interpretation of Contract Documents, delays and Claims by the CONTRACTOR, the decision of the ENGINEER shall be final and binding unless the CONTRACTOR timely follows the appropriate procedures to object to the same as set forth herein under Claims and Disputes, or unless otherwise ordered by the Board or General Manager.

3.2. SUPERVISION BY CONTRACTOR

The CONTRACTOR is required to give personal attention to the fulfillment of this Contract, and to keep the Work under control. The CONTRACTOR shall have a copy of the Contract Documents available at the worksite at all times. During the CONTRACTOR's absence from the worksite, the CONTRACTOR shall provide a site superintendent with full authority to receive and execute such instructions, orders or directions as the ENGINEER may issue in connection with the provisions of the Contract Documents. The site superintendent shall be available on site at all times during progress of the Work.

The CONTRACTOR shall supervise and direct the Work competently and efficiently, devoting such attention thereto and applying such skills and expertise as may be necessary to

perform the Work in accordance with the Contract Documents. The CONTRACTOR shall be solely responsible for the means, methods, techniques, sequences and procedures of construction, but the CONTRACTOR shall not be solely responsible for the negligence of others in the design or selection of a specific means, method, technique, sequence, or procedure of construction which is indicated in and required by the Contract Documents except as otherwise provided in the General Conditions, entitled Errors and Omissions.

The CONTRACTOR shall be responsible to see that the completed Work complies with the Contract Documents.

Before any Work is done at the worksite, the CONTRACTOR shall give written notice to the ENGINEER stating the name, home address and telephone number of the CONTRACTOR's site superintendent. The ENGINEER shall be informed in writing prior to any change of site superintendent. A statement naming more than one representative at a time to be in charge, depending upon which is present at the time, will not be acceptable.

The CONTRACTOR shall file with the ENGINEER the names, addresses, and telephone numbers of representatives who can be contacted at any time in case of emergency. These representatives must be fully authorized and equipped to correct unsafe or excessively inconvenient conditions on short notice.

If a site superintendent or the CONTRACTOR is not present at a particular location of the worksite, the ENGINEER may inform the foreman, or other person in charge, regarding an interpretation of the Contract Documents or of any disapproval or rejection of materials or Work performed. Information so given shall be as binding as if given to the superintendent.

3.3. CONTRACTING AND ASSIGNMENT

Subcontractors not specifically listed in the Bid Submittal or otherwise disclosed to MCSD will not be recognized as such and will not be allowed to work on the Project unless the value of said Work is less than one-half of one percent of the total Contract Price. All persons engaged in the Work of construction will be considered as employees of the CONTRACTOR, and not as independent contractors. No assignment of any portion of the Work or of any obligation or duty under the Contract is permitted without the express prior written consent of MCSD, and as otherwise authorized by the Contract Documents.

4. LEGAL RELATIONS AND RESPONSIBILITIES

4.1. LAWS TO BE OBSERVED

The CONTRACTOR shall, at its own cost and expense, observe and keep fully informed regarding all existing and future federal, state, city, county, local agency or special district laws and regulations which may in any manner affect those engaged or employed on the Project, or the materials to be used or furnished, or which may in any respect govern, control or otherwise affect the conduct of the Project or any part thereof. The CONTRACTOR shall, at its own cost and expense, furnish all materials and facilities required to comply with such laws and

regulations. The CONTRACTOR shall furnish copies of all valid licenses and certifications required of Suppliers, Subcontractors, or employees for the Work upon the request of the ENGINEER.

If any discrepancy or inconsistency is discovered on the Plans, Specifications, permits, or in the Contract Documents for the Project in relation to any such law, regulation, order or decree, the CONTRACTOR shall forthwith report the same to MCSD, in writing, and shall cease operations on that part of the Work until MCSD has given the CONTRACTOR appropriate instructions as provided for in General Conditions, Errors and Omissions.

The CONTRACTOR shall defend and indemnify MCSD, the Board of Directors, the ENGINEER, the CONSULTANT, and its subconsultants, each of their directors, officers, employees or agents against any claim or liability arising from or based on the violation of any such law, or regulation, whether by the CONTRACTOR or any of the CONTRACTOR's employees or agents, including its Subcontractors and Suppliers.

Attention is directed to the following specific regulations and requirements that are included in the Contract Documents. This list of regulations is not warranted to be complete and the burden of ascertaining legal requirements that must be satisfied shall rest solely with the CONTRACTOR.

- A. Employment of Apprentices. The CONTRACTOR and any Subcontractor shall comply with the requirements of Sections 1777.5 and 1777.6 of the California Labor Code in the employment of apprentices.

Information relative to apprenticeship standards, wage schedules and other requirements may be obtained from the Director of Labor Relations, c/o the Administrator of Apprenticeship, San Francisco, California, or from the Division of Apprenticeship Standards and its branch offices.

A CONTRACTOR or Subcontractor that is determined by the chief of the Division of Apprenticeship Standards to have knowingly violated Labor Code Section 1777.5 shall forfeit as a civil penalty an amount not to exceeding One Hundred Dollars (\$100) for each full calendar day of noncompliance. A contractor or subcontractor that knowingly commits a second or subsequent violation within a three-year period, if the noncompliance results in apprenticeship training not being provided as required by this chapter, shall forfeit as a civil penalty the sum of not more than three hundred dollars (\$300) for each full calendar day of noncompliance. (California Labor Code Section 1777.7)

- B. Travel and Subsistence Payments. Each worker needed to execute the Work must be paid travel and subsistence payments as defined in the applicable collective bargaining agreements filed in accordance with California Labor Code Section 1773.1.
- C. Hours of Labor. The CONTRACTOR shall forfeit, as a penalty to MCSD, twenty-five dollars (\$25) for each worker employed in the execution of the Contract by the CONTRACTOR or any Subcontractor, for each calendar day during which such worker is

required or permitted to work more than eight (8) hours in any one (1) calendar day and forty (40) hours in any one (1) calendar week in violation of the provisions of the Labor Code and, in particular, Section 1810 to Section 1815 thereof, inclusive, except that work performed by employees of CONTRACTOR in excess of eight (8) hours per day and forty (40) hours during any one (1) week shall be permitted upon compensation for all hours worked in excess of eight (8) hours per day at not less than 1-1/2 times the basic rate of pay as provided in said Section 1815.

- D. Nondiscrimination in Employment. The CONTRACTOR shall comply with Government Code §12940. Projects under this Contract will obligate the CONTRACTOR and Subcontractors not to discriminate in employment practices. CONTRACTOR must, if requested, submit a compliance report concerning its employment practices and policies. The CONTRACTOR must be prepared to comply in all respects with the requirements regarding nondiscrimination including but not limited to California Labor Code Section 1735.
- E. Prevailing Wage Rates. The CONTRACTOR shall comply with California Labor Code Section 1771 by the payment of prevailing wages as established by the Director of the State Department of Industrial Relations. In accordance with Labor Code Section 1775, the CONTRACTOR and any Subcontractor shall forfeit, as a penalty to MCSD, not more than Two Hundred Dollars (\$200) for each calendar day or portion thereof for each worker paid less than the established prevailing rates for such work or craft in which such worker is employed for any Work done under the Contract in violation of the provisions of the California Labor Code Sections 1770 to 1780, inclusive. In addition to said penalty and pursuant to said Section 1775, for each day or portion thereof in which each worker was paid less than the prevailing wage rate the difference between such established prevailing wage rates and the amount paid to each worker shall be paid to each worker by the CONTRACTOR. Per California Labor Code 1773.2, MCSD will have on file copies of the prevailing rate of per diem wages at its principal office and at each job site, which shall be made available to any interested party upon request.
- F. California Department of Industrial Relations (DIR) Registration and Record of Wages.
- 1) The CONTRACTOR and its subcontractors shall comply with the registration requirements of Labor Code §1725.5. Pursuant to Labor Code §1771.4, the Work is subject to compliance monitoring and enforcement by the DIR.
 - 2) The CONTRACTOR shall maintain accurate payroll records and shall comply with all of the provisions of Labor Code §1776, and shall submit payroll records to the Labor Commissioner pursuant to Labor Code §1771.4(a)(3). Penalties for non-compliance with the requirements of §1776 may be deducted from progress payments per §1776.
 - 3) Pursuant to Labor Code §1776, the CONTRACTOR shall furnish a copy of all certified payroll records to MCSD and/or the general public upon request, provided the public request is made through MCSD, the Division of Apprenticeship

Standards or the Division of Labor Enforcement of the Department of Industrial Relations.

- 4) The CONTRACTOR shall comply with the job site notices posting requirements established by the Labor Commissioner per Title 8, California Code of Regulations §16461(e) or other regulation promulgated pursuant to Labor Code Section 1771.4(a)(2).

G. Public Records Act.

1) Ownership and Disclosure

Except as otherwise provided herein, all records, documents, Drawings, Plans, Specifications, and all other information relating to the conduct of MCSD's business, including information submitted by the CONTRACTOR ("Records"), shall become the exclusive property of MCSD and shall be deemed public records. Said Records are subject to the provisions of the California Public Records Act (Government Code § 6250 et. seq.). MCSD's use and disclosure of its records are governed by this Act. MCSD will use its best efforts to inform the CONTRACTOR of any request for any financial records or documents marked "Trade Secret", "Confidential" or "Proprietary" provided by the CONTRACTOR to MCSD. MCSD will not advise as to the nature or content of documents entitled to protection from disclosure under the California Public Records Act.

2) Litigation Related to Disclosure

In the event of litigation concerning the disclosure of any Records, MCSD's sole involvement will be as a stakeholder, retaining the Records until otherwise ordered by a court. The submitting party, at its sole expense and risk, shall be fully responsible for any and all fees for prosecuting or defending any action concerning the Records and shall indemnify and hold MCSD harmless from all costs and expenses including attorney's fees in connection with any such action.

H. Subcontracting. Pursuant to the provisions of Sections 4100 to 4114, inclusive, of the California Public Contract Code, as amended from time to time, the CONTRACTOR shall not, without the consent of MCSD:

- 1) Substitute any person(s) or Subcontractor(s) designated in the original Bid.
- 2) Assign or transfer any subcontract or allow any subcontract to be performed by anyone other than the original Subcontractor.
- 3) Sublet or subcontract any portion of the Project not so designated in the original Bid when the value of said Work is greater than one-half of one percent (1/2%) of the CONTRACTOR's total Bid.

A violation by the CONTRACTOR of any of the provisions of Sections 4100 to 4114, inclusive, of the Public Contract Code, shall be deemed a violation of the Contract and MCSD will impose the penalties provided therein.

- I. Workers' Compensation. Pursuant to the requirements of California Labor Code Section 1860, the CONTRACTOR shall secure the payment of compensation to CONTRACTOR's employees in accordance with the provisions of Section 3700 of the California Labor Code.
- J. California Air Resources Board (CARB) In-Use Off-Road Diesel Fleets Regulation.
 - 1) The CONTRACTOR and its subcontractors shall comply with all applicable CARB regulations, including, without limitation, all applicable requirements of CARB's regulations governing In-Use Off-Road Diesel-Fueled Fleets, 13 CCR §§ 2449-2449.3.
 - 2) Pursuant to 13 CCR § 2449(i)(1), if applicable, prior to entering into the Contract, the CONTRACTOR shall provide MCSD with a valid Certificate of Reported Compliance from CARB for all vehicles to be used by CONTRACTOR and/or any of its subcontracts for Work under the Contract that are subject to CARB's In-Use Off-Road Diesel Fleets Regulations. If the Project qualifies as an "emergency operation" as defined in 13 CCR §2449(c)(18), pursuant to 13 CCR § 2449(i)(4), in lieu of providing Certificates of Reported Compliance as required above, CONTRACTOR may, instead provide MCSD with an attestation from itself and/or its subcontractors that the vehicles are operated on the Project for emergency operations only.
- K. State Regulations. All requirements applicable, as established by CalEPA, CalOSHA, CARB, DIR, or other state regulatory agencies.
- L. Federal Regulations. All requirements applicable, as established by the EPA, OSHA, or other federal regulatory agencies.

4.2. GENERAL INDEMNIFICATION

The CONTRACTOR shall, with respect to all Work covered by or incidental to these Contract Documents, be responsible for any liability imposed by law and shall indemnify, defend and hold MCSD, the ENGINEER, the CONSULTANT and its subconsultants, and each of their directors, officers, agents and employees, and all public entities issuing permits to the CONTRACTOR, free and harmless from and against all of the following:

Any claim, suit or action of every name, kind, and description, loss, damage, cost, expenses, including reasonable attorney's fees and expert fees, costs of compliance with administrative orders and directives, litigation, arbitration, awards, fines, and administratively or judicially-imposed penalties or judgments, arising by reason of death or bodily injury to person(s), injury to property, or other loss, damage or expense, resulting from the construction of the Work, design defects (if design originated by the CONTRACTOR only), defects in the Work, or by

or on account of acts, errors or omissions of the CONTRACTOR or CONTRACTOR's Subcontractors, Suppliers, employees, invitees, or agents or from any other cause whatsoever arising during the progress of the Work or at any time prior to its completion and Final Acceptance, including any of the same resulting from MCSD's alleged or actual acts, errors, or omissions regardless of whether on or off of the worksite. Said responsibility shall extend to claims, demands or liability for loss, damage or injuries occurring or discovered after completion of the Work, as well as during the progress of the Work. However, the CONTRACTOR shall not be obligated under this Contract to indemnify MCSD, the ENGINEER or its CONSULTANT(s) with respect to the active negligence, sole negligence, or willful misconduct of MCSD, the ENGINEER, or its CONSULTANT(s).

In addition, if any action is brought against the CONTRACTOR or any Subcontractor to enforce a stop payment notice or Notice to Withhold, which names MCSD as a party to said action, MCSD shall be entitled to reasonable attorney's fees, costs and necessary disbursements arising out of the defense of such action by MCSD. MCSD shall be entitled to deduct its costs for any stop payment notice filed, whether court action is involved or not.

In any and all claims against the indemnified parties by an employee of the CONTRACTOR, any Subcontractor, any Supplier, anyone directly or indirectly employed by any of them, or anyone for whose acts any of them may be liable, the indemnification obligation as specified herein shall not be limited in any way by the amount or type of damages, compensation, or benefits payable by or for the CONTRACTOR, or any Subcontractor, or any Supplier or other person under Workers' Compensation acts, disability benefit acts, or other employee acts.

The obligations of the CONTRACTOR as specified herein shall not extend to the liability of the ENGINEER, the CONSULTANT or its subconsultants, and each of their directors, officers, agents and employees, arising out of or resulting from or in connection with the preparation or approval of maps, Drawings, opinions, reports, surveys, designs or Specifications, provided that the foregoing was the sole and exclusive cause of the loss, damage or injury.

The CONTRACTOR shall also be responsible for and shall indemnify, defend and hold harmless MCSD, the ENGINEER, the CONSULTANT and its subconsultants, and each of their directors, officers, employees, and agents from and against all losses, expenses, damages (including damages to the Work itself), attorney's fees, and other costs, including all costs of defense, which any of them may incur with respect to the failure, neglect, or refusal of the CONTRACTOR to faithfully perform the Work and all of the CONTRACTOR's obligations under the Contract. Such costs, expenses, and damages shall include all costs, including attorney's fees incurred by the indemnified parties in any lawsuit to which they are a party.

In the event CONTRACTOR or its insurer refuses or fails to provide a legal defense to MCSD after receiving written notice of the legal action and a tender and demand for defense, MCSD shall have the right to select counsel of its own choice to represent all the interests of MCSD at CONTRACTOR's cost and expense. CONTRACTOR agrees that the amount of legal costs and expenses, including attorneys' fees, may be withheld by MCSD from any Contract amounts due and owing to CONTRACTOR until such time as a final determination is made as

to the responsibility for payment of said fees and costs. CONTRACTOR further agrees that to the extent MCSD incurs such damages and the damages exceed any remaining Contract amounts due and owing to CONTRACTOR, CONTRACTOR shall reimburse MCSD for all such additional damages upon demand by MCSD for the same.

CONTRACTOR and MCSD agree that nothing in this Section is intended to be or is a prevailing party clause as it pertains to attorney's fees.

4.3. JOINT AND SEVERAL LIABILITY

If the CONTRACTOR is a joint venture or partnership, each venturer or partner shall be jointly and severally liable for any and all of the duties and obligations of the CONTRACTOR that are assumed under or arise out of the Contract. Each of such venturers or partners waives notice of the breach or non-performance of any undertaking or obligation of the CONTRACTOR contained in, resulting from or assumed under the Contract, and the failure to give any such notice shall not affect or impair such venturer's or partner's joint and several liability hereunder.

4.4. RESPONSIBILITY FOR LOSS, DAMAGE OR INJURY

Neither MCSD, nor its Directors, officers, employees or agents shall be held responsible in any manner for any loss or damage that may happen to the Work or any part thereof during the course of construction; for any loss or damage to any of the materials, equipment, supplies or other things used or employed in performing the Work; for injury to or death of any person, either workers or the public; or for damage to property, from any cause that might have been prevented by the CONTRACTOR, CONTRACTOR's workers, or anyone employed by the CONTRACTOR.

In the event any hazardous materials, including but not limited to asbestos, are utilized in construction or hazardous materials are otherwise encountered during construction, the CONTRACTOR shall take all appropriate precautions to protect persons and property and shall comply with all applicable regulations for the installation, removal, and handling of such hazardous materials. The CONTRACTOR is solely responsible for protection of persons and property that could be affected by construction and the CONTRACTOR's handling of such materials.

4.5. OWNERSHIP OF PLANS, SPECIFICATIONS, SHOP DRAWINGS

All Plans, Specifications, shop drawings, other drawings, permits, reports, licenses, etc., used for this Project are the property of MCSD and shall not be used for any other work. Nothing in this Contract shall be construed to vest in CONTRACTOR any property right in any Plans, Specifications, shop drawings, other drawings, permits, reports, licenses, or other Project-related documents, nor shall the CONTRACTOR obtain any property right in any material, article or structure within the Project area which is in existence at the time the Contract is awarded or subsequently is furnished by the CONTRACTOR to MCSD and becomes a part of the Project.

4.6. PRESERVATION OF PROPERTY

The CONTRACTOR shall exercise reasonable care to avoid injury to existing improvements or facilities, utility facilities, any private or public property wherever located, trees, shrubbery and other landscaping which are not to be removed. The CONTRACTOR is required to familiarize itself with the worksite.

All trees, shrubbery, landscaping which are not to be removed, and pole lines, fences, signs, survey markers and monuments, buildings, structures and improvements, conduits, pipelines (under or aboveground), sewers, waterlines, highway or street facilities, and any other improvements or facilities with respect to any private or public property wherever located shall be protected from injury or damage. The CONTRACTOR shall provide and install suitable safeguards to protect such objects from injury or damage.

If such objects are injured or damaged by reason of the CONTRACTOR's operation, they shall be replaced or restored at the CONTRACTOR's expense to a condition equivalent to their condition prior to such injury or damage or as required by the Contract Documents.

The CONTRACTOR is obligated to respond to a notification of damages to any private or public property wherever located caused by CONTRACTOR's operations by beginning work on emergency repairs/restorations immediately, and in no event later than 4 hours from said notification and on non-emergency repairs/restorations within 72 hours of said notification. Within these required timeframes, the CONTRACTOR must begin efforts to resolve issues of responsibility for any damages or losses for any asserted claim. For any claims the CONTRACTOR asserts are not related to its operations, the CONTRACTOR must provide MCSD with written notice to MCSD stating its position and all documentation supporting the same, as well as written proof of referral to its insurance carrier and its determination, along with detailed rationale for any denial of coverage or denial of the claim. Said proof shall be submitted to MCSD within 30 days of the date of notification to the CONTRACTOR of the damages or losses.

In the event that the CONTRACTOR does not respond in the manner required herein and within the required timeframes, MCSD may determine the validity of the claim and perform the repair/restoration work itself or have another contractor or qualified entity perform the same, and CONTRACTOR's next progress payment shall be reduced in amount commensurate with the cost of the repair/restoration work and/or resulting damages as a Contract deduction. If the cost of the repair/restoration work and/or resulting damages exceeds the amounts remaining due under the Contract, CONTRACTOR shall reimburse MCSD for all remaining costs and/or damages immediately.

The fact that any pipe or other underground facility is not shown on the Contract Documents, or is shown in a different location, shall not relieve the CONTRACTOR of responsibility under this section. The CONTRACTOR shall be responsible for avoiding all injury or damage to any type of underground utility facility.

In addition to any requirements imposed by law, the CONTRACTOR shall shore up, brace, underpin, and protect as may be necessary, all foundations and other parts of all existing structures adjacent to and adjoining the worksite which are, or may be, in anyway affected by the excavations or other operations connected with the performance of the Work. Whenever any notice is required to be given by MCSD or the CONTRACTOR to any adjacent or adjoining landowner or other party before commencement of any Work, such notice shall be given by MCSD, unless the CONTRACTOR is directed otherwise by MCSD.

In an emergency affecting the safety of life or property, including adjoining property, the CONTRACTOR, without special instructions or authorizations, is authorized to act with discretion to prevent such threatened loss or injury.

4.7. PERSONAL LIABILITY

No director, officer, employee, or agent of MCSD, or its CONSULTANT, shall be personally responsible for any liability arising under or by virtue of the Contract.

4.8. WARRANTY OF TITLE

No materials, supplies or equipment for the Work under this Contract shall be purchased subject to any chattel mortgage or under a conditional sale contract or other agreement by which an interest therein or any part thereof is retained by the seller or Supplier. The CONTRACTOR warrants clear and good title to all materials, supplies, and equipment installed and incorporated in the Work and agrees, upon completion of all Work, to deliver the Work together with all improvements and appurtenances constructed or placed thereon to MCSD free from any claims, liens, encumbrances, or charges, and further agrees that neither the CONTRACTOR, nor any person, firm, or corporation furnishing any material or labor for any Work covered by the Contract shall have any right to a lien upon the premises or any improvement or appurtenance thereon, provided that this shall not preclude the CONTRACTOR from installing metering devices or other equipment of utility companies or of municipalities, the title to which is commonly retained by the utility company or the municipality.

Nothing contained in this section shall defeat or impair the right of such persons furnishing materials or labor, under any bond given by the CONTRACTOR for their protection, or any right under any law permitting such persons to look to unpaid funds due the CONTRACTOR in possession of MCSD. The provisions of this section shall be inserted in all subcontracts and material contracts, and notices of its provisions shall be given to all persons furnishing materials for the Work when no formal contract is entered into for such materials.

The CONTRACTOR is responsible for, and shall be obligated to pay, all stop payment notice claims asserted and proved to be an obligation of the CONTRACTOR.

4.9. PROPERTY RIGHTS IN MATERIAL

Nothing in these Contract Documents shall be construed as vesting in the CONTRACTOR any right of property in the materials used after they have been attached or affixed to the Work or the soil, or after payment has been made for materials delivered to the worksite or stored subject to or under the control of MCSD.

All such materials shall become the property of, and title shall pass to, MCSD upon being so attached or affixed or upon payment for materials delivered to the worksite or stored subject to or under the control of MCSD. The CONTRACTOR shall promptly execute, acknowledge and deliver to MCSD proper bills of sale or other written instruments of title in a form as required by MCSD. The written instrument of title shall convey to MCSD title to material, goods, and/or equipment for the Work free and clear of debts, claims, liens, mortgages, taxes and/or encumbrances. If title has not been vested in MCSD previously, title shall pass to MCSD upon Final Acceptance.

The CONTRACTOR at its own expense shall conspicuously mark such material, goods and equipment necessary for the Work as the property of MCSD, and shall not permit such material, goods and equipment necessary for the Work to become commingled with non-MCSD owned materials, equipment or goods, and shall take such other steps MCSD may require or regard as necessary to vest title to such material, goods and equipment necessary for the Work to MCSD free and clear of debts, claims, liens, mortgages, taxes and/or encumbrances.

Transfer of title of Work to MCSD shall not constitute or imply MCSD's acceptance of the Work. Notwithstanding the transfer of title, the CONTRACTOR shall continue to be liable and responsible to MCSD for any damage to or loss of Work until the Work achieves Final Acceptance, as defined herein.

Soil, stone, gravel and other materials found at the worksite and which conform to the Contract Documents for incorporation into the Work may be used in the Work. No other use shall be made of such materials except as may be otherwise described in the Contract Documents.

4.10. TERMINATION FOR DEFAULT

If the CONTRACTOR refuses or fails to prosecute the Work or any separable part thereof with such diligence as will ensure its completion within the time specified herein, or any authorized extension thereof, or fails to perform the Work in a manner required by the Contract Documents and/or industry standards, or fails to complete such Work within such time as required under the Contract Documents or, if the CONTRACTOR should be adjudged as bankrupt, or is otherwise deemed insolvent by MCSD based on good cause and is unable to proceed with the Work, or if the CONTRACTOR should make a general assignment for the benefit of creditors, or if a receiver should be appointed on account of insolvency, or if the CONTRACTOR files a petition to take advantage of any debtor's act, or should any Subcontractor violate any of the provisions of the Contract, or if the CONTRACTOR should persistently or repeatedly refuse or fail, except in cases for which an authorized extension of

time is provided, to supply enough properly skilled workers or proper materials to complete the Work in the time specified, or if the CONTRACTOR should fail to make prompt payment to Subcontractors for material or labor, or if the CONTRACTOR should persistently disregard laws, or instructions given by MCSD, or if the CONTRACTOR otherwise substantially fails to fulfill its obligations under the Contract Documents, MCSD may, without prejudice to any other right or remedy, serve written notice upon the CONTRACTOR and Sureties of MCSD's intention to terminate the CONTRACTOR's performance under the Contract. Said notice shall contain the reasons for such intention to terminate the CONTRACTOR's performance under the Contract, and unless, within ten (10) days after the service of such notice, such violations cease and/or satisfactory arrangements for the corrections thereof have been made, the MCSD may terminate CONTRACTOR's performance under the Contract and the CONTRACTOR shall not be entitled to receive any further payment until the Work is finished.

In the event of any such termination, MCSD shall serve written notice thereof upon the Surety and CONTRACTOR, and the Surety shall have the right to take over and perform the Contract. However, if the Surety, within five (5) days after the service of a notice of termination, does not give MCSD written notice of its intention to take over and perform the Contract, and if it serves such notice of its intent to take over and perform the Contract and does not begin performance thereof within fifteen (15) days from the date of serving said notice, MCSD may take over the Work and prosecute the same to completion by contract or by any other method it may deem advisable for the account and at the expense of the CONTRACTOR, and the Sureties and/or CONTRACTOR shall be liable to MCSD for any excess cost or other damage incurred by MCSD thereby. In such an event MCSD may without liability for so doing, take possession of and utilize such materials, tools, equipment, supplies and other property belonging to the CONTRACTOR and/or assume assignment of any and all subcontracts for Subcontractors and/or Suppliers that may be on the worksite and be necessary to complete the Work. For any portion of such Work that MCSD elects to complete by furnishing its own employees, materials, tools, and equipment, MCSD shall be compensated in accordance with the schedule of compensation for force account work as stated in the General Conditions section entitled Contract Price Adjustments and Payments.

If the Surety assumes the CONTRACTOR's terminated Work, it shall take the CONTRACTOR'S place in all respects for that part and shall be paid by MCSD for all Work performed by it in accordance with the terms of the Contract Documents. If the Surety assumes the entire Contract, all money due the CONTRACTOR at the time of its default shall be payable to the Surety as the Work progresses, subject to the terms of the Contract.

CONTRACTOR hereby consents to assigning to MCSD and/or MCSD's replacement contractor all subcontracts and other agreements of any and all Subcontractors and/or Suppliers that may be on the worksite and/or may be necessary to complete the Work in the event of Termination for Default or Termination for Convenience, as set forth below. CONTRACTOR agrees to obtain, by way of a subcontract provision, the consent of each and every Subcontractor and/or Supplier for such assignment prior to the commencement of each such Subcontractor's and/or Supplier's Work on the Project.

In the event of such termination, the CONTRACTOR will be paid the actual amount due based on unit prices or lump sums Bid and the quantity of Work completed at the time of termination, less damages caused to MCS D by acts of the CONTRACTOR causing the termination, including but not limited to, all costs to MCS D arising from professional services and attorneys' fees and all costs generated to insure or bond the Work of substituted contractors or subcontractors utilized to complete the Work, such excess shall be paid to the CONTRACTOR. If such costs exceed the unpaid balance, the CONTRACTOR shall pay the difference to MCS D promptly upon demand. On failure of the CONTRACTOR to pay, the Surety shall pay on demand by MCS D. Any portion of such difference not paid by the CONTRACTOR or Surety within thirty (30) days following the mailing of a demand for such costs shall earn interest at the maximum rate authorized by California law.

The CONTRACTOR and MCS D agree that nothing in this section is intended to be or is a prevailing party clause as it pertains to attorney's fees.

The foregoing provisions are in addition to and not in limitation of any other rights or remedies under law or in equity available to MCS D.

If it is later determined by MCS D that the CONTRACTOR had an excusable reason for not performing, such as a fire, flood, or other event which was not the fault of or was beyond the control of the CONTRACTOR, MCS D, after setting up a new performance schedule, may allow the CONTRACTOR to continue Work, or treat the termination as a termination for convenience, and the rights and obligations of the parties shall be the same as if the termination had been issued for the convenience of MCS D.

4.11. TERMINATION FOR CONVENIENCE

MCS D may terminate the CONTRACTOR's performance under the Contract, either in whole or in part, at its own discretion or when conditions encountered during the Work make it impossible or impracticable to proceed, or when MCS D is prevented from proceeding with the Contract by act of God, by law, or by official action of a public authority, or upon a determination that such termination is in the best interest and convenience of MCS D, or whenever MCS D is prohibited from completing the Work for any reason. MCS D shall provide no less than ten (10) days written notice of its intent to terminate the Contract for convenience, and shall provide the CONTRACTOR with consultation with MCS D prior to termination.

Upon receipt of such written notice of termination, the CONTRACTOR shall:

1. Stop Work as specified in the written notice;
2. Terminate all orders and Subcontractors except as necessary to complete Work which is not terminated;
3. If directed in writing by MCS D to do so, assign all right, title and interest in subcontracts and materials in progress, in which case MCS D will have the right at its discretion to settle, or pay any or all claims arising out of the termination of such

Subcontractors, but in no event shall recovery by any CONTRACTOR include lost profits for uncompleted portions of Work;

4. Deliver or otherwise make available to MCSD all data, Drawings, Specifications, reports, estimates, summaries and such other information and material as may have been accumulated by the CONTRACTOR in performing this Contract whether completed or in process;
5. Settle outstanding liabilities and claims with the approval of MCSD;
6. Complete performance of such part of the Work as has not been terminated; and
7. Take such other actions as may be necessary, or as may be directed by MCSD for the protection and preservation of the Project and/or property related to the Contract.

Upon receipt of MCSD's written notice of termination for convenience, and within a period of 30 to 60 days, as determined by the ENGINEER at the time of termination, the CONTRACTOR shall submit to the ENGINEER a Termination Proposal which shall include, but is not limited to, the CONTRACTOR's estimated costs to be incurred by the CONTRACTOR as a result of the termination for convenience, and as allowed by the Contract Documents, including all documentation to support such costs; the status of the Work at time of termination; the status of termination of the CONTRACTOR'S Subcontractor(s) and Supplier(s) agreement(s) including the amount of each said agreement, amount paid under each agreement up to the date of termination, and the amount that currently remains due and owing under each agreement for Work completed as of the date of termination, if any; a list, certified as to quantity and quality, of termination inventory not previously disposed of, excluding items authorized for disposition by the ENGINEER; and any other information and/or documentation as required by MCSD.

Upon receipt of MCSD's written notice of termination for convenience, the CONTRACTOR shall submit to the ENGINEER a request for Final Payment, pursuant to the requirements set forth herein. Such request shall be submitted promptly, but no later than sixty (60) days from the effective date of termination.

The Final Payment to the CONTRACTOR after termination for convenience shall be limited to amounts due and owing under the Contract at time of termination, including the following:

1. Any actual costs incurred by the CONTRACTOR for restocking charges;
2. The agreed upon price of protecting the Work in any manner, if any, as directed by MCSD;
3. The cost of settling and paying claims arising out of the termination of the Work under subcontract agreements or orders with MCSD's approval, as specified above, exclusive of the of the amounts paid or payable on account of goods delivered or Work furnished by Subcontractor prior to the effective date of the termination; and

4. The Contract Price allocable to the portion of the Work properly performed or goods supplied by the CONTRACTOR as of the date of termination, as determined in accordance with the within Sections herein entitled Payment – General and Contract Price Adjustments And Payments, reduced by any sums previously paid to the CONTRACTOR.

MCSD shall have the right to withhold any portion or the whole of the Final Payment under this provision in the event there are any outstanding claims for compensation asserted by MCSD against the CONTRACTOR, or by any third party against MCSD which arises out of the CONTRACTOR's Work.

4.12. NOTICE AND SERVICE THEREOF

Any notice required or given under the Contract shall be in writing, be dated, and signed by the party giving such notice or its duly authorized representative, and be served as follows:

If to MCSD, by personal delivery or by deposit in the United States mail, or by electronic telecommunication.

If to the CONTRACTOR, by personal delivery to the CONTRACTOR or to its authorized representative at the worksite or by deposit in the United States mail, or by electronic telecommunication.

If to the Surety or any other person, by personal delivery to the Surety or other person or by deposit in the United States mail or by electronic telecommunication.

All mailed notices shall be in sealed envelopes, shall be sent by certified mail with postage prepaid, return receipt requested, and shall be addressed to the addresses and addressees contained in the Contract Documents, or such substitute addresses which a party designates in writing and serves as set forth herein.

All electronic telecommunication, to be effective, shall have a date and time receipt acknowledgment, and shall be clearly identified as a contractual notice under this, and any other applicable, provision of the Contract.

4.13. PARTIAL INVALIDITY

In the event any article, section, paragraph, sentence, clause, or phrase (collectively referred to hereinafter as "Contract Elements" or singularly as "Contract Element") contained in the Contract Documents shall be determined, declared, or adjudged invalid, illegal, unconstitutional, or otherwise unenforceable, such determination, declaration, or adjudication shall in no manner affect the other Contract Elements, which shall remain in full force and effect as if the Contract element declared, determined, or adjudged invalid, illegal, unconstitutional, or otherwise unenforceable, was not originally contained in the Contract Documents.

4.14. WAIVER OF RIGHTS

Except as otherwise specifically provided in the Contract Documents, no action or failure to act by MCSD, ENGINEER or CONTRACTOR shall constitute a waiver of any right or duty afforded any of them under the Contract Documents, nor shall any such actions or failure to act constitute an approval of or acquiescence in any breach thereunder.

4.15. TAXES

The CONTRACTOR shall pay all sales, consumer, use and other taxes.

4.16. ASSIGNMENT OF ANTITRUST ACTIONS

In entering into a public works contract or subcontract to supply goods, services or materials pursuant to a public works contract, the CONTRACTOR or Subcontractor offers and agrees to assign to MCSD all rights, title and interest in and to all causes of action it may have under Section 4 of the Clayton Act (15 U.S.C.A. Section 15), or under the Cartwright Act (Chapter 2 [commencing with Section 16700] of Part 2 of Division 7 of the California Business and Professions Code), arising from purchases of goods, services or materials pursuant to the public works contract or subcontract. This assignment shall be made and become effective at the time MCSD tenders Final Payment to the CONTRACTOR, without further acknowledgment by the parties.

In submitting a Bid to MCSD, the Bidder offers and agrees that if the Bid is accepted, it will assign to MCSD all rights, title, and interest in and to all causes of action it may have under Section 4 of the Clayton Act (15 U.S.C.A. Section 15), or under the Cartwright Act (Chapter 2 [commencing with Section 16700] of Part 2 of Division 7 of the California Business and Professions Code), arising from purchases of goods, materials or services by the Bidder for sale to the purchasing body, pursuant to the Bid. Such assignment shall be made and become effective at the time MCSD tenders Final Payment to the Bidder.

4.17. SUBCONTRACTING

If the CONTRACTOR subcontracts any part of the Contract, the CONTRACTOR shall be as fully responsible to MCSD for the acts, errors and omissions of the Subcontractor(s) and Suppliers and of the person(s) either directly or indirectly employed by the Subcontractor(s) and Suppliers as the CONTRACTOR is for the acts, errors and omissions of persons directly employed by the CONTRACTOR. Nothing contained in the Contract Documents shall create any contractual relationship between any Subcontractor/Supplier and MCSD. The divisions and sections of the Specifications and the identifications of any Drawings shall not control the CONTRACTOR in dividing the Work among Subcontractors.

4.18. FLOW-DOWN REQUIREMENTS

Each Subcontract and Supplier agreement shall preserve and protect the rights of MCSD, its directors, officers, agents, and employees under the Contract Documents with respect to the

Work to be performed by the Subcontractor so that subcontracting thereof will not prejudice such rights, and shall allow to the Subcontractor or Supplier, unless specifically provided otherwise in the subcontract agreement, the benefits of all rights, remedies and redress against the CONTRACTOR that the CONTRACTOR, by the Contract Documents, has against MCSD. Where appropriate, the CONTRACTOR shall require each Subcontractor and Supplier to enter into similar agreements with sub-Subcontractors. The CONTRACTOR shall make available to each proposed Subcontractor or Supplier, prior to the execution of the subcontract, copies of the Contract Documents. In addition, upon the request of MCSD, the CONTRACTOR shall make available to MCSD any and all Subcontract and Supplier agreements pertaining to the Project and the Work thereunder. By appropriate agreement, written where legally required for validity, the CONTRACTOR shall require:

1. Each Subcontractor and Supplier to be bound to the CONTRACTOR by the terms of the Contract Documents;
2. Each Subcontractor and Supplier shall assume toward the CONTRACTOR all obligations and requirements and responsibilities, including the responsibility for safety of the Subcontractor's Work, which the CONTRACTOR, by the Contract Documents, assumes toward MCSD;
3. Each Subcontractor and Supplier shall require all subcontracted Work to be performed in accordance with the Contract Documents and that with respect to the Work the Subcontractor or Supplier performs that the Subcontractor or Supplier assume toward the CONTRACTOR all the obligations and responsibilities which the CONTRACTOR assumes toward MCSD.
4. Each of its Subcontractors or Suppliers to include in their contracts with lower-tier Subcontractors or Suppliers these same requirements, and to require each Subcontractor or Supplier to make copies of the Contract Documents available to the Sub-Subcontractors or sub-Suppliers.

This section does not and shall not operate to relieve the CONTRACTOR of any duty or liability under the Contract Documents, nor does it create any duty or liability on the part of MCSD. The CONTRACTOR shall have sole responsibility for promptly settling any disputes between its Subcontractors and between the Subcontractors and any of their lower-tier Subcontractors.

4.19. ASSIGNMENT

The performance of all or any portion of the Contract may not be assigned except upon the written consent of MCSD, and as specifically provided herein. Consent will not be given to any proposed assignment that would relieve the original CONTRACTOR or the Sureties of responsibilities under the Contract.

Upon obtaining prior written consent of MCSD, the CONTRACTOR may assign monies due or to become due under the Contract, to the extent permitted by law, but any assignment of

monies shall be subject to all proper setoffs in favor of MCSD and to all deductions provided for in the Contract. In particular, all monies withheld, whether assigned or not, shall be subject to being used by MCSD for the completion of the Work in the event that the CONTRACTOR should default.

No assignment of the Contract will be approved unless it contains a provision that the funds to be paid to the assignee under the assignment are subject to a prior lien for services rendered or materials supplied for performance of the Work called for under the Contract in favor of all persons, firms, or corporations rendering such services or supplying such materials and that MCSD may withhold funds due until all Work required by the Contract Documents is completed to MCSD's satisfaction.

4.20. WARRANTY (CONTRACTOR'S GUARANTEE)

- A. The CONTRACTOR shall and hereby does guarantee the entire Work, and its performance through maintenance of sufficient warranties, that the entire Work shall perform at all times as part of a fully integrated system consisting of all Work elements specified in the Contract Documents for a period of one (1) year after the Final Acceptance of the Work by MCSD. Any portion of the Work that is Beneficially Occupied shall be additionally warranted as described, in these General Conditions, Use Prior to Final Completion (Beneficial Occupancy). During the warranty period, the CONTRACTOR shall repair or remove and replace any Work, together with any other work which may be displaced in so doing that is found to be defective in workmanship and/or materials without any expense to MCSD, ordinary wear and tear and unusual abuse or neglect excepted. In the event of failure to comply with the above-mentioned conditions within one (1) week after being notified in writing, MCSD is hereby authorized to proceed to have the defects remedied at the expense of the CONTRACTOR who hereby agrees to pay the cost and charges thereof immediately on demand. The CONTRACTOR's warranty shall continue as to any corrected deficiency until the later of:
1. The remainder of the original one-year warranty period; or
 2. One year after acceptance by MCSD of the corrected Work.
- B. Such action by MCSD will not relieve the CONTRACTOR of the warranties required by this section or elsewhere in the Contract Documents.
- C. All guarantees and warranties, expressed or implied shall inure to the benefit of both MCSD and the CONTRACTOR during the performance of the Work. Upon Final Completion of the Work, such guarantees and warranties shall inure to the benefit of MCSD.
- D. The Performance Bond and the Payment Bond shall continue in full force and effect for the warranty period, including all extensions thereof as provided by the Contract Documents.

- E. If, in the opinion of MCSD, defective Work is detected during the warranty period which creates a dangerous condition or requires immediate correction or modification to prevent further loss to MCSD or to prevent interruption of MCSD operations, MCSD will attempt to give the notice required by this section. If the CONTRACTOR cannot be contacted or does not comply with MCSD's request for correction within a reasonable time as determined by MCSD, MCSD may, notwithstanding the provisions of this section, proceed to make such correction or provide such modification. The costs of such correction or modification shall be charged against the CONTRACTOR. Such action by MCSD will not relieve the CONTRACTOR of the warranties required by this section or elsewhere in the Contract Documents.
- F. This section does not in any way limit the warranty on any items for which a longer warranty is specified or on any items for which a manufacturer or Supplier gives a warranty for a longer period. The CONTRACTOR agrees to act as a co-guarantor with such manufacturer or Supplier and shall furnish MCSD all appropriate guarantee or warranty certificates upon completion of the Project and acceptance by MCSD. No warranty period, whether provided for in this section or elsewhere, shall in any way limit the liability of the CONTRACTOR, Sureties or insurers.

4.21. SAFETY PRECAUTIONS AND EMERGENCIES

A. CONTRACTOR's Responsibility for Safety.

CONTRACTOR shall be responsible for initiating, maintaining and supervising all safety precautions and programs in connection with the Work. This requirement will apply continuously twenty four hours a day every day until Final Acceptance of the Work and shall not be limited to normal working hours. The duties of MCSD, Engineer and Inspector do not include review of the adequacy of CONTRACTOR's safety measures in, on, or about the site and vicinity.

B. Safety Officer.

Contractor shall designate a responsible member of its organization at the site of the Work whose duty shall be the prevention of hazards and accidents. This person shall be CONTRACTOR's Superintendent unless otherwise designated in writing by CONTRACTOR to the ENGINEER.

C. Safety Measures.

Contractor shall comply with all Codes and lawful orders of any public authority having jurisdiction for the safety of persons or property or to protect them from damage, injury or loss. Contractor shall comply with the "Manual of Accident Prevention in Construction" published by the Associated General Contractors of America, Inc., including the recommendations for safe construction methods and the requirements for the guarding of machinery and equipment therein, to the extent that the provisions of the manual are not in conflict with applicable Codes and orders. CONTRACTOR shall maintain copies of all

documents mentioned or referenced in this paragraph readily available at the site until the Work is completed.

D. Warnings and Barricades.

CONTRACTOR shall provide and maintain barricades, guards, temporary bridges and walkways, watchmen, night lights and danger signals illuminated from sunset to sunrise, and all other necessary appliances and safeguards to protect the Work, life, property, the public, excavations, equipment, and materials. Barricades shall be of substantial construction and shall be painted such as to increase their visibility at night. Suitable warning signs shall be so placed and illuminated at night as to show in advance where construction, barricades, or detours exist. Guard rails shall be provided for bridges and walkways over or adjoining excavations, shafts, and other openings and locations where injury may occur.

E. Fire Prevention.

CONTRACTOR's Safety Officer shall inspect the entire Work and site, including storage areas, at frequent intervals to verify that fire prevention measures are constantly enforced.

F. Flammable or Toxic Materials.

Only a working supply of flammable or toxic materials shall be permitted in or on any of the permanent structures and improvements, and shall be removed therefrom at the end of each day's operations. CONTRACTOR shall store flammable or toxic materials and waste separate from the Work and stored materials for the Work in a manner that prevents spontaneous combustion or dispersion, and none shall be placed in any sewer or drain piping nor buried on the Owner's property.

G. Safety Helmets, Clothing, and Equipment.

CONTRACTOR shall not permit any person for whom he is responsible or liable to enter or remain on the site of the Work unless the person is equipped with and wearing a safety helmet and other protective clothing and safety equipment conforming to the requirements of paragraph C. "Safety Measures," and shall discharge from the site all persons not so equipped.

H. Hazardous Areas.

CONTRACTOR shall not permit or allow any person or persons to enter any pipe or space containing hazardous or noxious substances or gases, or where there is an insufficient amount of oxygen to sustain life and consciousness, or any other hazardous area unless equipped with lawful and appropriate safety equipment and life supporting apparatus, and unless those entering are continually monitored and guarded by and in communication with other persons outside the space or area who are equipped in the same way, can give an alarm to others for assistance, and initiate immediate rescue operations in the event of mishap.

I. Emergencies.

CONTRACTOR shall perform any and all operations and shall furnish any materials and equipment necessary during an emergency endangering life or property and, in all cases, shall notify the ENGINEER of the emergency as soon as practicable, but shall not wait for instruction before proceeding to properly protect both life and property.

CONTRACTOR shall file with the ENGINEER a written list giving the names, addresses, and telephone numbers of at least two of his representatives who can be contacted at any time in case of emergency. The representatives shall be fully authorized and equipped to correct unsafe or inconvenient conditions on short notice. CONTRACTOR shall promptly notify the ENGINEER of all changes in the listing.

5. SCOPE OF WORK

5.1. GENERAL

The intent of the Contract Documents as they apply to the Project is to prescribe and provide for the complete and finished performance and accomplishment, in every respect, of the entire contemplated Work indicated in the Contract Documents, relating directly to the Project. It shall be understood that the CONTRACTOR undertaking the execution of all or any part of such Work shall be required to perform in a craftsman-like manner and in strict compliance with Contract Documents, and to furnish and provide in connection therewith all transportation, labor, tools implements, equipment, materials, supplies, services and other items which are necessary or appurtenant to construct and complete the entire Project, including but not limited to all applicable codes, permits, ordinances, regulations, and laws.

5.2. CONSTRUCTION PROCEDURES AND PROTECTION

A. CONTRACTOR's Plant and Equipment.

CONTRACTOR shall furnish modern plant and equipment as necessary to perform the Work in a manner satisfactory to the ENGINEER and in accordance with the Contract Documents, types and designs that comply with the requirements herein and with the requirements prescribed by Codes pertaining to wind and seismic forces at the place of the Project. Construction equipment or machinery that at any time produces unsatisfactory results shall be promptly repaired or replaced by the Contractor and as the ENGINEER may require.

B. Use of Site.

CONTRACTOR shall confine its equipment, the storage of materials and equipment, and the operations of those directly and indirectly employed by it to areas permitted by applicable Codes and the Contract Documents, and shall not unreasonably encumber the

site with materials and equipment. Nothing in the Contract Documents shall grant to the Contractor exclusive occupancy of the site of the Work and Project.

C. Overloading.

No part of the Work or new and existing structures, scaffolding, shoring, sheeting, construction machinery and equipment, or other permanent and temporary facilities shall be loaded with weights or subjected to stresses or pressures that endanger any of them. CONTRACTOR shall bear the cost of correcting damage caused by overloading or excessive stresses or pressures.

D. Use of Explosives.

CONTRACTOR shall comply with all laws, ordinances, regulations, codes, and orders governing the transportation, storage, and use of explosives, shall exercise extreme care not to endanger life or property, and shall be responsible for all injury or damage resulting from the use of explosives for or on the Work. No blasting shall be done in the vicinity of existing structures above or below the ground without the prior written consent of the owner thereof.

E. Cutting and Patching.

CONTRACTOR shall perform all cutting, fitting, or patching of the Work that may be required to make its several parts fit together properly and satisfactorily, and shall not endanger any Work, structures, adjacent property, workmen, or the public by cutting, excavating, or otherwise altering the Work or any part of it. CONTRACTOR shall restore all such cut or patched Work and improvements as approved by the ENGINEER.

F. Verification of Installed Work.

CONTRACTOR shall correct all defects in installed Work of the Contract before subsequent related or connected Work is applied or installed. Where the Contract Documents require a material or item of equipment to be applied or installed under the supervision, inspection, or direction of the supplier or manufacturer, or his representative, the supplier, manufacturer, or his representative shall inspect the applicable installed Work and issue a letter to the ENGINEER stating the corrections required to or approval of the installed Work before his material or equipment is installed or applied.

G. Manufacturers' Instructions.

Unless otherwise provided in the Contract Documents, CONTRACTOR shall apply, install, erect, connect, use, clean, condition, and operate manufactured articles, materials, and equipment in accordance with the various manufacturers' instructions. CONTRACTOR shall compare the requirements of the various manufacturers' instructions with the requirements of the Contract Documents, shall promptly notify the ENGINEER in writing of any difference between such requirements, and shall not proceed with any of the Work affected by such differences until an interpretation or clarification is issued.

CONTRACTOR shall bear all costs for any error in the Work resulting from its failure to so compare the various requirements and notify the ENGINEER of any such differences.

H. Public Convenience.

CONTRACTOR shall at all times so conduct its operations as to ensure the least possible obstruction and inconvenience to traffic and the general public and the residents in the vicinity of the Work, to protect persons and property, and to preserve access to driveways, house, and buildings. CONTRACTOR shall have under construction no greater amount of Work than it can properly perform with due regard to the rights of the public, and shall not create any public nuisance. No road, street, or highway shall be closed to the public except with the permission of the proper authorities. Where existing streets are not available as detours, CONTRACTOR shall permit traffic to safely pass through the Work with as little delay and inconvenience as possible, unless otherwise authorized by the ENGINEER. CONTRACTOR shall furnish competent flagmen whose sole duty shall be the directing of traffic through or around the Work when ordered by the ENGINEER, required by public authorities having jurisdiction, or required by law. At no time shall CONTRACTOR prevent free access to fire hydrants, water and gas main valves, manholes or vaults, or other utility facilities except as otherwise required to perform the Work and in compliance with all Codes and permits. CONTRACTOR shall make temporary provisions to ensure the use of walkways and sidewalks and the proper functioning of gutters, sewer and storm drain inlets, and ditches, which shall not be obstructed.

I. Protection.

CONTRACTOR shall take all precautions and furnish and maintain protection to prevent damage, injury, or loss to all employees and workmen on the Work and all other persons who may be affected thereby; all the Work and all materials and equipment to be incorporated therein, whether in storage on or off the site, under the care, custody or control of CONTRACTOR or any of its Subcontractors; and other improvements and property at the site or where Work is to be performed including buildings, trees and plants, pole lines, fences, guard rails, guide posts, culvert and project markers, signs, structures, conduits, pipe lines, and improvements within or adjacent to streets, rights of way, or easements, except those items required to be removed by the Contractor in the Contract Documents. The Contractor's protection shall include all the safety precautions required under General Conditions Section entitled "Safety Precautions and Emergencies" and other necessary forms of protection, and the notification of the owners of utilities and adjacent property.

Unless otherwise provided in the Contract Documents or unless otherwise cared for by the owner thereof, all water, gas, oil, or irrigation lines, all lighting, power, communication, or telephone conduits, all sewer and drainage lines and house connection lines, sprinkling systems, and other subsurface structures of any nature along the Work shall be maintained by CONTRACTOR at its expense, and shall not be disturbed, disconnected, or damaged by CONTRACTOR during the progress of the Work. CONTRACTOR shall install temporary pipes of adequate size to carry off sewage from any sewer facilities cut off by construction operations. Installation of temporary pipes shall be made immediately upon cutting of the existing facility, and no sewage shall be allowed to flow from any severed

facility upon the ground surface or in the trench excavation. Pipe used in temporary sewers may be clay, metal, concrete, or composition. Before completion of Work, CONTRACTOR shall replace all severed connections and restore to operating order the existing sanitary facilities with matching materials and construction. No liquid from any severed facility shall be allowed to flow upon the ground surface or in any excavation.

Except for those improvements and facilities required to be permanently removed by the Contract Documents, CONTRACTOR shall make satisfactory and acceptable arrangements with the appropriate owners and, at its expense, shall repair and restore all improvements, structures, property, utilities, and facilities disturbed, disconnected, or damaged as a result or consequent of its Work or the operations of those for whom he is responsible or liable, including that caused by trespass of any of them with or without his knowledge or consent, or by the transporting of workmen, materials, or equipment to or from the site.

5.3. ERRORS AND OMISSIONS

The CONTRACTOR, as part of this Contract, shall agree not to take advantage of errors or omissions in the Contract Documents. It is the duty of the CONTRACTOR to promptly notify the ENGINEER in writing of any design, materials, or specified method that the CONTRACTOR believes may prove defective or insufficient. If the CONTRACTOR believes that a defect or insufficiency exists in design, materials or specified method and fails to promptly notify the ENGINEER in writing of this belief, the CONTRACTOR thereby waives any right to assert that defect or insufficiency in design, materials or specified method at any later date in any legal or equitable proceeding against MCSD, or in any subsequent arbitration or settlement conference between MCSD and the CONTRACTOR. The ENGINEER, upon receipt of any such notice, will promptly investigate the circumstances and give appropriate instructions to the CONTRACTOR. Until such instructions are given, any Work done by the CONTRACTOR after the CONTRACTOR becomes aware that a defect or insufficiency exists in design, materials or specified method which is directly or indirectly affected by such alleged defect or insufficiency in design, materials or specified method will be at the CONTRACTOR's own risk and the CONTRACTOR shall bear all costs arising therefrom. In the event the CONTRACTOR believes that the ENGINEER's instruction results in a change to the Contract Documents or Work requiring a change to the period of Contract performance or Contract Price, CONTRACTOR must submit a Request for Change in the time and manner set forth in the Section herein entitled Request for Change (Changes at CONTRACTOR's Request).

If the CONTRACTOR, either before commencing Work or in the course of the Work, finds any discrepancy between the Contract Documents, or the physical conditions at the worksite, or finds an error or omission on the Plans or in any survey, the CONTRACTOR shall promptly notify the ENGINEER in writing of such discrepancy, error or omission. If the CONTRACTOR observes that the Contract Documents are at variance with any applicable law, regulation, order, or decree, the CONTRACTOR shall promptly notify the ENGINEER in writing of such conflict. The ENGINEER, on receipt of such notice, will promptly investigate the circumstances and give appropriate instructions to the CONTRACTOR. Until

such instructions are given, Work done by the CONTRACTOR after the discovery of such error, discrepancy, or conflict which is directly or indirectly affected by such error, discrepancy, omission or conflict will be at the CONTRACTOR's own risk and the CONTRACTOR shall bear all costs arising therefrom. In the event the CONTRACTOR believes that the ENGINEER's instruction results in a change to the Contract Documents or Work requiring a change to the period of Contract performance or Contract Price, CONTRACTOR must submit a Request for Change in the time and manner set forth in the Section herein entitled Request for Change (Changes at CONTRACTOR's Request).

Any Work or material not herein specified or shown on the Contract Documents, but which by fair implication in the judgment of the ENGINEER, should be included therein, shall be accomplished or furnished by the CONTRACTOR as part of the Contract requirements.

5.4. REQUEST FOR CHANGE (CHANGES AT CONTRACTOR'S REQUEST)

A. General

The CONTRACTOR may request an equitable adjustment if it considers any Work which is demanded by the ENGINEER in writing to be "Extra Work" and outside the requirements of the Contract Documents or in variance to the same, or otherwise causes the CONTRACTOR to accelerate or decelerate the Work or causes a delay to the Work. Equitable adjustments may also be requested if the CONTRACTOR identifies what it believes to be errors or omissions of any kind, including design errors or omissions, in the Contract Documents or encounters a differing site condition that could not reasonably have been foreseen, and any such occurrence or direction materially changes the Contract Documents or Work and/or which may require a change to the period of performance or Contract Price (either additive or deductive). The CONTRACTOR shall within three (3) days after any such demand, instruction, ruling, occurrence, discovery, or decision is made, notify the ENGINEER in writing by way of a document entitled "Request for Change" (RFC). The RFC shall set out in specific detail all objections such as why the requested Work is not in the scope of the Contract Documents and the reasons therefore, and/or the reason why the required Work is outside the scope of the Contract Documents, the identification of the Contract Document, term, condition, or specification proposed to be altered, changed, added, or deleted, and why the CONTRACTOR believes additional compensation or time will or may be due as a result thereof.

Except for RFCs which are made in the manner and within the time stated above, the CONTRACTOR shall be deemed to have waived, and does by execution of the Contract knowingly waive all Claims for Extra Work, damages and extensions of time resulting from demand, instructions, rulings and decisions of the ENGINEER. Except for requests for equitable adjustment based on defective Specifications, no requests for equitable adjustment hereunder shall be allowed for any costs incurred more than 3 days before the CONTRACTOR gives written notice as required herein. In the case of defective Specifications for which MCSD is responsible, if there are any increased direct costs reasonably incurred by CONTRACTOR in attempting to comply with those defective Specifications, CONTRACTOR will be entitled to recovery of any such increased direct

costs if the Request for Change is made in accordance with the procedures set forth herein, Request for Change (Changes At CONTRACTOR's Request) and/or OWNER Initiated Changes. CONTRACTOR, however, is not relieved of its obligation at time of Bid to have reviewed the Contract Documents and identified any patent errors or omissions in the same; and it shall bear all costs arising from any such failure.

B. Request for Change Submissions; Cost and Schedule Proposals

All RFCs shall be dated, numbered sequentially, and shall describe the action or event which the CONTRACTOR believes may require equitable adjustment. The CONTRACTOR shall also provide a description of possible CONTRACTOR actions or solutions to minimize the cost of the RFC, and it shall provide a cost and schedule proposal for said Work based upon an estimate of the cost for the anticipated changed Work, and shall submit said price and time impact to the ENGINEER whose approval shall be secured before Work is started. The cost and schedule proposal shall include, at a minimum, the following:

1. A detailed cost breakdown of the changed Work organized and subtotaled by specification section in a spreadsheet format specified by the ENGINEER itemizing all costs associated with the Extra Work, deletion or revision, including material, labor, equipment, etc. in a manner evidencing the logical computation and allocation of costs, and the CONTRACTOR must also include all necessary back-up documentation including quantities, labor man-hours, unit prices, and Supplier and Subcontractor quotations to support said estimate, and any other data, information and/or documentation required by the ENGINEER. Costs for preparing cost or schedule proposals are not compensable.
2. If an adjustment to the Contract period of performance is requested, the delay must be substantiated and documented by the CONTRACTOR. In accordance with the schedule requirements in the Specifications, an accurately updated Project schedule proving time impacts and actual delay to critical path activity is required, unless otherwise directed in writing by the ENGINEER, and shall be accompanied by any and all documentation as more particularly specified herein, General Conditions, Extension of Time for Delay. The CONTRACTOR shall also include the identification of labor, materials and/or other cost items including overhead and Subcontractor costs, which have been or may be added, deleted or wasted by such delay, and a statement that the CONTRACTOR is maintaining records which allows the separately identifiable direct costs due to the delay, and those not incurred as a result of the delay, to be readily identifiable and segregated.
3. In addition, the CONTRACTOR shall include with its cost and/or schedule proposal a certification, executed by a duly authorized representative of the CONTRACTOR, stating the following, or the RFC shall be considered incomplete and shall not be accepted by MCSD:

“I certify that (1) the Request for Change is made in good faith, (2) I have reviewed all supporting documentation and data, which is included herewith, and it is accurate and complete, (3) I have determined from my independent review of the Request for Change that the same is meritorious, and that the amount and/or time extension requested accurately reflects the Contract adjustment for which I believe MCSD is liable; and (4) I am duly authorized to certify the Request for Change on behalf of the CONTRACTOR.”

4. CONTRACTOR shall submit three printed copies of the complete proposal along with an electronic copy of the proposal on a compact disc in a file format acceptable to MCSD.

Extra Work shall be priced by CONTRACTOR and paid by MCSD consistent with the allowable costs set forth in the Section herein entitled “Contract Price Adjustments and Payment.”

Upon receipt of the CONTRACTOR’s RFC, the ENGINEER shall review the same and shall promptly advise the CONTRACTOR in writing of the final decision. The final decision shall be binding, subject however to the approval of the Board of Directors or General Manager, to the extent the final decision changes the Contract Documents and a Change Order is required. If additional information is needed to evaluate the Request for Change, the ENGINEER may at its sole discretion request that the CONTRACTOR submit such additional information or documentation as may be needed to evaluate the RFC. By issuing any request for additional information, the ENGINEER shall not be deemed to have made a determination as to the merit of the CONTRACTOR’s Request for Change or as to the nature of the Work in question, and in no event shall it be deemed a direction to proceed with said Work. The CONTRACTOR shall submit any further information or documentation requested by the ENGINEER, whose approval shall be secured before Work is started. In the event negotiations are necessary to determine an appropriate cost and/or schedule adjustment to the Contract, the CONTRACTOR shall negotiate in good faith with the MCSD.

C. Authority to Direct Extra Work

The ENGINEER may, when in the best interest of MCSD issue a Change Order to the CONTRACTOR to proceed with the Extra Work including the Work identified in the RFC in advance of its cost and schedule proposal submission. MCSD reserves the right to reject any requests for equitable adjustment for Extra Work or for additional payment requested as a result of extending the Work under the Bid prices which has not been approved by the ENGINEER in the manner herein provided.

When the price for Extra Work, deletions or other revisions cannot be agreed upon, or the CONTRACTOR fails or refuses to negotiate in good faith with respect to the same, MCSD may issue a unilateral change using its independent estimate and time impact analysis, as more particularly specified in these General Conditions, Contract Price Adjustments and

Payments. MCSD may also direct such Work on a time and materials or force account basis.

To the extent the ENGINEER directs Extra Work to be performed on a time and materials or force account basis, such Extra Work shall be performed by the CONTRACTOR, and compensated by MCSD, in the time and manner set forth in General Conditions Section entitled, "Contract Price Adjustments and Payments," Sub-section D thereto, "Time & Material and Force Account Work."

In the event the CONTRACTOR disagrees with any findings made by the ENGINEER as it concerns entitlement to a Change Order, or any portion thereof, additional compensation under the Contract, or adjustment to period of performance, CONTRACTOR shall proceed with the Claims procedures set forth herein. CONTRACTOR also agrees to diligently proceed with the performance of the Contract, including the delivery of goods or providing of services in accordance with ENGINEER's instructions. CONTRACTOR's failure to diligently proceed in accordance with ENGINEER's instructions shall be considered a material breach of the Contract.

D. Minor Changes

Changes in the Work not materially affecting the efficiency or usability of the finished facility, which do not involve extra or lesser cost, and are not inconsistent with the intent of the Contract Documents or detrimental to the Project or to the interests of MCSD, may be granted by the ENGINEER to facilitate the Work of the CONTRACTOR when such changes are requested, in writing, and submitted to the ENGINEER for approval. In the event such changes are granted in writing by the ENGINEER, the changes shall be made without additional cost to MCSD. The CONTRACTOR will be responsible for all costs associated with future changes or conflicts that are caused by the CONTRACTOR's requested change. It shall be understood that nothing herein shall be construed as granting permissive rights to the CONTRACTOR to demand acceptance of such requested changes.

5.4. OWNER INITIATED CHANGES

A. General

MCSD reserves and shall have the right, without invalidating the Contract and without notice to the Surety(ies), to have changes made within the general scope of the Contract Documents consisting of Extra Work, deletions or other revisions. The signing of the Contract Documents by the CONTRACTOR will be deemed to be an agreement on its part to perform Extra Work, as and when ordered by the ENGINEER.

Upon decision of MCSD to have Extra Work performed, the ENGINEER will so inform the CONTRACTOR, acquainting the CONTRACTOR with the essential details of the Extra Work and issue a Request for Proposal ("RFP"). The CONTRACTOR shall thereupon, and within three (3) days, prepare a proposal for said Extra Work based upon an estimate of cost and submit said price and time impact analysis to MCSD whose

approval shall be secured before Extra Work is started. The ENGINEER may, when in the best interests of MCSD, order the CONTRACTOR to proceed with the Extra Work in advance of proposal submission. MCSD reserves the right to reject any Claims for Extra Work or for additional payment claimed as a result of extending the Work under the Bid prices which have not been approved by the ENGINEER in the manner herein provided.

B. Cost and Schedule Proposal

The CONTRACTOR's proposal must include, at a minimum, the items identified in the Section entitled "Request For Change (Changes At CONTRACTOR's Request)," subsection B.1 through B.4.

Extra Work shall be priced by CONTRACTOR and paid by MCSD consistent with the allowable costs set forth in the Section herein entitled "Contract Price Adjustments and Payment."

The ENGINEER shall review the CONTRACTOR's RFP submission of costs and/or delays and shall promptly advise the CONTRACTOR in writing of the final decision as to the adjustment to the Contract Price and/or period of performance, if any, to be made in the Contract Documents. The CONTRACTOR shall submit any further information or documentation requested by the ENGINEER, whose approval shall be secured before Extra Work is started. In the event negotiations are necessary to determine an appropriate cost and/or schedule adjustment to the Contract, the CONTRACTOR shall negotiate in good faith with MCSD. The ENGINEER's final decision shall be binding, subject however to the approval of the Board of Directors or General Manager, to the extent the final decision changes the Contract Documents and a Change Order is required.

C. Authority to Direct Extra Work

The ENGINEER may, when in the best interests of MCSD, order the CONTRACTOR to proceed with the Extra Work in advance of its cost and schedule proposal submission. MCSD reserves the right to reject any Claims for Extra Work or for additional payment claimed as a result of extending the Work under the Bid prices which has not been approved by the ENGINEER in the manner herein provided.

When the price for Extra Work, deletions or other revisions cannot be agreed upon, or the CONTRACTOR fails or refuses to negotiate in good faith with respect to the same, MCSD may issue a unilateral change using its independent estimate and time impact analysis, as more particularly specified in these General Conditions, Contract Price Adjustments and Payments. MCSD may also direct such Extra Work on a time and materials or force account basis.

To the extent the ENGINEER directs Extra Work to be performed on a time and materials or force account basis, such Extra Work shall be performed by the CONTRACTOR, and compensated by MCSD, in the time and manner set forth in General Conditions Section

entitled, "Contract Price Adjustments and Payments," "Time & Material and Force Account Work."

In the event the CONTRACTOR disagrees with any findings made by MCSD as it concerns adjustment to Contract Price or period of performance, CONTRACTOR shall proceed with the Claims procedures set forth herein. CONTRACTOR also agrees to diligently proceed with the performance of the Contract, including the delivery of goods or providing of services in accordance with MCSD's instructions. CONTRACTOR's failure to diligently proceed in accordance with MCSD's instructions shall be considered a material breach of the Contract.

D. Minor Changes

The ENGINEER may order in writing minor changes in the Work not involving an increase or decrease in the Contract Price, not involving a change in the time for completion, and not inconsistent with the Contract Documents or the purposes for which the Work is being constructed. If the CONTRACTOR believes that any order for minor changes in the Project involves changes in the Contract Price or time for completion, the CONTRACTOR shall not proceed with the minor changes so ordered and shall within three (3) days of the receipt of such order notify ENGINEER in writing of the estimate of the changes in the Contract Price and period of performance believed to be appropriate, and in the manner more particularly set forth herein at Request for Change (Changes At CONTRACTOR's Request).

5.5. CLAIMS

A. Claims Subject to Public Contract Code Section 20104, et seq.

For any Claim subject to Public Contract Code Section 20104 et seq., for Three Hundred Seventy-Five Thousand Dollars (\$375,000) or less, MCSD and CONTRACTOR shall comply with Public Contract Code Section 20104, et seq., for resolution.

B. Notice of Claim

Notwithstanding California Public Contract Code Section 20104.2(a), all Claims shall be filed with MCSD within twenty (20) days of MCSD's decision, act or omission which gives rise to the Claim, or prior to Final Completion, whichever occurs first. This notice requirement is specifically authorized by California Public Contract Code Section 20104.2(a). Unless such Claim is made and filed as herein prescribed, the Claim shall be forfeited and invalidated and the CONTRACTOR shall not be entitled to any relief, damages and/or payment in connection therewith. The presentation of such Claim, however, shall not be deemed evidence of any liability for the alleged damage on the part of MCSD or MCSD agent.

C. Claims Not Subject to Public Contract Code Section 20104, et seq.

For any Claim, including any disagreement between the parties as to the merits, amount or remedy arising from the Project or Contract Documents not subject to Public Contract Code Section 20104, et seq., the provisions of Public Contract Code Section 20104, et seq., are hereby incorporated and shall apply to all such Claims except as follows:

1. The time period in which the Claim shall be filed with MCSD as set forth in Section 20104.2(a) shall be within twenty (20) days of MCSD's decision, act or omission which gives rise to the Claim, or prior to Final Completion, whichever occurs first.
2. MCSD's 60 day response period set forth in Section 20104.2(c) (1) shall be extended to 90 days from receipt of the Claim.

D. For all Claims submitted by the CONTRACTOR, CONTRACTOR shall include all documentation necessary to substantiate the Claim, which includes, but is not limited to all documentation required to be submitted with the initial Request for Change, pursuant to the General Conditions, Request for Change (Changes At CONTRACTOR's Request), OWNER Initiated Changes and/or Extension of Time for Delay, as applicable, plus any additional documentation or narrative that may have been inadvertently omitted from the initial submission to MCSD and/or ENGINEER, including an explanation as to why said documentation or narrative was not previously included, and any and all documentation, written narratives or other evidence addressing and/or responding to the basis for rejection of the initial Claim including a Request for Change, either in whole or in part, as provided by the ENGINEER and/or MCSD.

E. Pending the final resolution of any Claims arising under, related to or involving this Contract, CONTRACTOR agrees to diligently proceed with the performance of this Contract, including the delivery of goods or providing of services in accordance with MCSD's instructions. CONTRACTOR's failure to diligently proceed in accordance with MCSD's instructions shall be considered a material breach of the Contract.

5.6. DISPUTES

A. For all Claims, including any and all disagreements between the parties as to the merits, amount or remedy arising out of an issue in controversy pertaining to the Project and/or Contract Documents, which remain unresolved after the CONTRACTOR submitted the same to the ENGINEER or MCSD for resolution in accordance with these General Conditions, Claims, the CONTRACTOR shall follow the disputes procedure as provided in Chapter 1 (commencing with Section 900) and Chapter 2 (commencing with Section 910) of Part 3 of Division 3.6 of Title 1 of the Government Code, unless otherwise specified by the Special Provisions. For purposes of those provisions, the running of the period of time within which a dispute must be filed shall be tolled from the time the CONTRACTOR submits its written Claim pursuant to Public Contract Code Section 20104.2(a) and these General Conditions, Claims, until the time that Claim is denied as a result of the meet and confer process, including any period of time utilized by the meet and confer process.

- B. Unless any dispute is made and filed as herein prescribed the dispute shall be forfeited and invalidated and the CONTRACTOR shall not be entitled to any relief, damages, and/or payment in connection therewith.
- C. Pending the final resolution of any dispute arising under, related to or involving this Contract, CONTRACTOR agrees to diligently proceed with the performance of this Contract, including the delivery of goods or providing of services in accordance with MCSD's instructions. CONTRACTOR's failure to diligently proceed in accordance with MCSD's instructions shall be considered a material breach of the Contract.

6. PROSECUTION AND PROGRESS OF THE WORK

6.1. PROGRESS OF THE WORK

The CONTRACTOR shall not commence Work until a Notice to Proceed from MCSD has been received. After receipt of the Notice to Proceed, the CONTRACTOR shall commence Work, and shall thereafter diligently prosecute the same in accordance with the Construction Schedule to complete the Work within the specified time limits of the Contract.

6.2. TEMPORARY SUSPENSION OF WORK

The ENGINEER shall have the authority to suspend the Work wholly or in part, for such period as deemed necessary, due to unsuitable weather, or to such other conditions as are considered unfavorable for the suitable prosecution of the Work, or for such time as deemed necessary due to the failure on the part of the CONTRACTOR to carry out instructions given, or to perform any provision of the Contract. The CONTRACTOR shall immediately comply with the written order of the ENGINEER to suspend the Work wholly or in part. The suspended Work shall be resumed when conditions are favorable and methods are corrected, as ordered by the ENGINEER.

If a suspension of Work is ordered by the ENGINEER due to the failure on the part of the CONTRACTOR to carry out orders given or to perform any provision of the Contract, the CONTRACTOR shall bear all costs associated with the suspension of Work and no extension of time for the completion of the Work shall be granted.

6.3. EXTENSION OF TIME FOR DELAY

If the Work should be delayed at any time by Extra Work or by reason of a suspension ordered by MCSD or because of any other act of MCSD or its officers or employees without contributory fault or neglect on the part of the CONTRACTOR or its agents or employees or its Subcontractors and/or Suppliers or if the Work should be delayed by reason of strikes or abnormal force or violence of the elements or for any other unforeseeable cause beyond the control and without the fault or negligence of the CONTRACTOR, then the CONTRACTOR

may be entitled to an extension of time for completion of the Work equivalent to the time actually lost by such delay.

When any such delays are experienced by the CONTRACTOR and a time extension is requested, the CONTRACTOR shall submit to the ENGINEER, a written time impact analysis illustrating the effects of the change or delay on the current Contract completion date utilizing the Construction Schedule that is current at the time the change or delay is encountered within the time and manner specified herein, and in accordance with Request for Change (Changes At CONTRACTOR's Request) and MCSD Initiated Changes.

The CONTRACTOR shall, within three (3) days from the beginning of any such delay, or within a period of time otherwise agreed upon in writing by the ENGINEER, file a written request with MCSD for extension of time which if initiated by the CONTRACTOR shall be submitted in the form of a Request for Change, as specified herein, Request for Change (Changes At CONTRACTOR's Request) or if the change is initiated by MCSD by the issuance of a Request for Proposal. Failure to do so shall constitute a waiver thereof. Requests for extensions failing to include the information specified in this section or within the time specified above shall result in the forfeiture of the CONTRACTOR's right to receive any extensions of time requested. MCSD will ascertain the facts and the extent of the delay, and its findings of the facts thereon shall be final and conclusive.

Each time impact analysis shall include a Fragnet demonstrating how the CONTRACTOR proposes to incorporate the change or delay into the current Construction Schedule. The Fragnet shall include the sequence of new and/or existing activity revisions that are proposed to be added to the accepted Construction Schedule that is current at the time the change or delay is encountered.

Each time impact analysis shall demonstrate the estimated time impact based on the events of the delay, the anticipated or actual date of the changed Work performance, the status of construction at that point in time, and the event time computation of all activities affected by the change or delay. The event times used in analysis shall be those included in the latest update of the current Construction Schedule in effect at the time the change or delay was encountered. Time extensions will be granted only to the extent that demonstrated time adjustments for the activity or activities affected exceed the total or remaining float along the critical path of activities at the time of actual delay or changed Work performance. Pursuant to the float sharing requirements as described elsewhere in the Contract Documents, time extensions shall not be granted nor delay damages paid until a delay occurs which:

1. Is beyond the control and without the fault or negligence of the CONTRACTOR and its Subcontractors or Suppliers, at any tier; and,
2. Extends actual performance of the Work beyond the current Contract completion date and the most recent date predicted for completion of the Work on the accepted Construction Schedule update that is current as of the time of the delay.

A written request for an extension of time or the granting of an extension of time shall not, in itself, constitute a basis for any Claim against MCSD for additional compensation, or a waiver of MCSD'S right to strictly enforce the time provisions contained in the Contract Documents. Additionally granting of an extension of time shall not in itself constitute a basis for any Claim against MCSD for additional compensation. The CONTRACTOR hereby waives any Claim for additional compensation unless a Claim for additional compensation on account of such delay is filed at the time the request for extension of time is made.

The determination as to whether an extension of time will be granted will be made within sixty (60) days after receipt of a request from the CONTRACTOR as provided above. In the event the CONTRACTOR disagrees with any findings made by MCSD as it concerns adjustment to the period of performance, CONTRACTOR shall proceed with the Claims procedures set forth herein.

No revision to the accepted baseline schedule or updates shall be made without prior written approval from the ENGINEER.

Schedule revisions illustrating the influence of Change Orders and delays shall be incorporated into the Construction Schedule during the first update after agreement is reached.

Any extension of time shall not release the Sureties upon any Bond required under the Contract.

6.4. LABOR COMPETENCY

If any Subcontractor, site superintendent, foreman or person(s) employed by the CONTRACTOR shall fail or refuse to carry out the directions of the ENGINEER or shall appear to the ENGINEER to be incompetent, or to act in a disorderly or improper manner, that person(s) shall be discharged immediately on demand of MCSD and such person(s) shall not again be employed on the Project.

The CONTRACTOR shall bear all costs associated with such discharge of any Subcontractor, site superintendent, foreman or person(s) employed by the CONTRACTOR and such discharge shall not constitute a basis for any Claim against MCSD.

6.5. USE PRIOR TO FINAL COMPLETION (BENEFICIAL OCCUPANCY)

- A. MCSD shall have the right to Beneficially Occupy all or a portion of the Work at no additional cost to MCSD.
- B. If MCSD elects to Beneficially Occupy any completed or partially completed portions of the Work, the ENGINEER shall so document in writing the scope of Work of which it elects to take possession and an inspection shall be made by the CONTRACTOR and ENGINEER of said scope of Work. Based on such inspection, the ENGINEER will attempt to list all incomplete and/or deficient items of Work observed, and provide the CONTRACTOR with such a list. However, the absence of an item from the list shall not relieve the CONTRACTOR of responsibility to perform all of the Work in accordance with

the Contract Documents, and any and all areas so occupied will be subject to Final Inspection after the CONTRACTOR completes all punchlist items, before Final Completion. If such prior use by MCSD delays the progress of the Work or causes additional expense to the CONTRACTOR, the CONTRACTOR shall file a written request for extension of time and/or Extra Work.

- C. Until Final Acceptance of the Work, CONTRACTOR shall guarantee, through the provision and maintenance of sufficient warranties, the following: that the portions of the Work Beneficially Occupied shall perform at all times as part of a fully integrated system consisting of all elements which are being Beneficially Occupied; that the portions of the Work Beneficially Occupied are free from all defects due to faulty materials, equipment or workmanship; and that CONTRACTOR shall promptly make whatever adjustments or corrections which may be necessary to cure any defects, including repairs of any damage to other parts of the system resulting from such defects. MCSD shall promptly give notice to the CONTRACTOR of observed defects. In the event that the CONTRACTOR fails to make adjustments, repairs, corrections or other work made necessary by such defects, MCSD may do so and charge the CONTRACTOR the cost incurred. The CONTRACTOR's warranty shall continue as to any corrected deficiency until the later of (1) the remainder of the original warranty period; or (2) one year after acceptance by MCSD of the corrected work. The Performance Bond and Payment Bond shall each remain in full force and effect through the warranty period.
- D. If MCSD's need to occupy the Work, or any portions thereof, prior to such time as the Work is complete is caused by the CONTRACTOR's failure to complete the Work within the period of performance, including due allowance for extensions of time made in accordance with the Contract Documents, if any, the CONTRACTOR shall bear any and all additional costs associated with completing the Work.

6.6. SUBSTANTIAL COMPLETION

Substantial Completion of the Work means the Work has progressed to the point that MCSD can beneficially occupy or utilize the Work as a whole for the purpose for which it is intended, and the Work complies with applicable codes and regulations, including if required, issuance of certificates of occupancy, or certificate of suitability for use from the appropriate governmental agencies, as determined by the ENGINEER at his/her sole discretion.

When the CONTRACTOR considers that Substantial Completion has been achieved, the CONTRACTOR shall notify the ENGINEER that the Work is substantially complete to the required stage and is ready for inspection and shall include with its Notice of Substantial Completion of the Work a list of minor items, (including the CONTRACTOR's punch list) to be completed or corrected that would not affect Beneficial Occupancy or suitability for use.

After receipt of the CONTRACTOR's Notice of Substantial Completion of Work, the ENGINEER and CONTRACTOR, and any other representative as the ENGINEER deems appropriate, shall make an inspection of the Work to determine whether the Work has been completed in accordance with the Contract Documents and to review the CONTRACTOR's

punch list. If, in the ENGINEER's sole opinion, the Work has not achieved Substantial Completion, the parties shall cease the inspection and all costs incurred by MCSD as a result of the premature inspection shall be deducted from the payments due the CONTRACTOR. CONTRACTOR shall thereafter perform all remaining Work to reach Substantial Completion, and re-submit its Notice of Substantial Completion of Work. The inspection of the Work will re-commence as set forth above. If the Work has achieved Substantial Completion, a punch list shall be prepared by the ENGINEER and consist of those items listed by the CONTRACTOR to be completed or corrected as supplemented by those items observed during the inspection. Failure to include any items on the punchlist shall not alter the responsibility of the CONTRACTOR to complete all Work in accordance with the Contract Documents, nor shall the punch list amend the Contract Documents. All deficiencies and/or items identified on the punch list must be corrected within 30 days of said initial inspection conducted at the Substantial Completion phase, unless otherwise specified in writing by the ENGINEER.

6.7. FINAL COMPLETION AND FINAL ACCEPTANCE

A. Final Inspection

The CONTRACTOR shall notify the ENGINEER in writing when all punch list items have been completed, all Work is completed in accordance with the Contract Documents and all clean-up has been done. Clean-up shall be completed when all waste, materials, excess materials, tools, and equipment such as scaffolding, temporary structures, and unneeded facilities such as fencing and sanitary facilities are removed from the Project. The ENGINEER will then make Final Inspection for the purposes of ascertaining that the Work has been fully completed in accordance with the requirements of the Contract Documents.

B. Final Completion

After the ENGINEER has made the Final Inspection and is satisfied that the Work has been completed in accordance with the Contract Documents, including all punch list items, and is satisfied that all submittals have been made and accepted, including, but not limited to all materials required by the Contract Documents and all As-Builts, Record Drawings by the CONTRACTOR, if required by the Contract, and any other required record documents have been completed and accepted, all Change Order Work has been completed and accepted by the ENGINEER, and all other requirements of the Contract Documents, except for any unexecuted Change Orders, possible future warranty and guarantee Work have been accomplished, the ENGINEER shall certify, in writing, the full completion of the Work and the date thereon.

C. Final Acceptance

The Work, after achieving Final Completion, is subject to Final Acceptance by MCSD. Final Acceptance is defined herein as the "action taken by MCSD accepting the Work as fully completed after certification by the ENGINEER," and occurs in accordance with the following:

CONTRACTOR is required to provide adequate resources to fully support administrative Project close-out efforts identified in the Contract Documents including but not limited to execution of all Change Orders, agreement on all final quantities and all other activities specified herein titled "Final Completion and Final Acceptance," General Conditions section titled "Final Payment." Such support and completion of all administrative close-out activities as required herein must be provided within the timeframe(s) requested by MCSD and is condition precedent to Final Acceptance.

The ENGINEER shall, after certifying the date of Final Completion of the Contract, make a final estimate of the amount of Work done thereunder, and the General Manager or designee shall certify the value of such Work and the date of Final Completion. If the Board finds that the Work has been completed according to the Contract Documents, it shall establish the date of Final Acceptance, and find and declare the Work accepted pursuant to this Section, which shall be evidenced by a Notice of Completion.

A Notice of Completion shall be recorded with the Orange County Clerk Recorder's Office immediately after the Final Acceptance, and in no event later than 10 days from Final Acceptance.

Only upon Final Acceptance shall Final Payment be processed. Processing of Final Payment shall occur in accordance with the provisions herein titled "Final Completion and Final Acceptance." Final Completion and Final Acceptance are for purposes of issuing Final Payment, and neither shall act to relieve the CONTRACTOR from any of its obligations under the Contract Documents, and under no circumstances shall Final Acceptance of the Contract Work waive any rights related to claims by MCSD pertaining to warranties and guarantees, latent defects, indemnity, fraud on the part of the CONTRACTOR, gross mistakes on the part of the CONTRACTOR amounting to fraud, or as otherwise provided in the Contract Documents.

6.8. TIME OF COMPLETION

The CONTRACTOR shall complete all or any designated portion of the Work called for under the Contract in all parts and requirements within the time set forth in the Contract Documents. If, at any time CONTRACTOR's critical path Work progress falls behind schedule, MCSD reserves the right to require the CONTRACTOR to work overtime to bring the Project back on schedule. Such overtime shall be at the CONTRACTOR's expense.

Failure of the CONTRACTOR to perform any covenant or condition contained in the Contract Documents within the time period specified shall constitute a material breach of this Contract entitling MCSD to terminate the CONTRACTOR's performance under the Contract unless the CONTRACTOR applies for, and receives, an extension of time in accordance with the procedures set forth in the section herein entitled Extension of Time for Delay, as well as any and all other remedies available to MCSD by law, in equity or pursuant to the provisions of this Contract.

Failure of MCSD to insist upon the performance of any covenant or condition within the time period specified in the Contract shall not constitute a waiver of the CONTRACTOR's duty to complete performance within the designated period unless the waiver is in writing.

MCSD's agreement to waive a specific time provision or to extend the time for performance shall not constitute a waiver of any other time provisions contained in the Contract Documents. Failure of the CONTRACTOR to complete performance promptly within the additional time authorized in the waiver or extension of time agreement shall constitute a material breach of this Contract entitling MCSD to terminate the CONTRACTOR's performance under the Contract and to any and all other legal or equitable remedies.

The CONTRACTOR shall not be assessed the cost of engineering and inspection during any delay in the completion of the Work caused by acts of God, acts of the public enemy, acts of the public utilities, delays caused by failure of a public agency or owner of a utility to provide for removal or relocation of existing main or trunkline utility facilities or other known utility facilities, fire, floods, earthquake, epidemic, quarantine restrictions, strikes, and unusually severe weather, or delays necessarily resulting from war or national or local emergencies, or delays of Subcontractors due to such causes; provided that the CONTRACTOR shall, within three (3) days from the beginning of any such delay, request an extension of time in accordance with the procedures set forth in this section and as specified in these General Conditions, Extension of Time for Delay. Such delays shall not entitle the CONTRACTOR to any additional compensation. The sole remedy of the CONTRACTOR shall be to seek an extension of time. MCSD shall ascertain the facts and the extent of the delay, and its findings of the facts thereon shall be final and conclusive.

7. PAYMENT FOR WORK

7.1. PAYMENT - GENERAL

Based on written estimates by the ENGINEER or on other evidence satisfactory to the General Manager, MCSD will make monthly progress payments for Work completed. Said progress payments will be based on an approved detailed breakdown of the Contract Price, which shall be furnished by the CONTRACTOR showing unit prices and quantities, as applicable.

Cost of materials will be based on Supplier's invoices. A complete list of invoices shall be presented to the ENGINEER by the CONTRACTOR prior to completion of each estimate. The CONTRACTOR must present to the ENGINEER written evidence substantiating that said purchase price has been paid in full.

Items shown in the detailed breakdown of the Contract Price as unit costs will be included in the progress payments based on the percentage completed for any particular item.

Each progress payment application shall show each Subcontractor and Supplier participating in the Work completed during the previous progress period and the dollar amount of such participation. If the CONTRACTOR disputes a Subcontractor's or Supplier's entitlement to a

portion of the previous progress payment, the CONTRACTOR shall submit copies of all communications between the CONTRACTOR and the Subcontractor explaining the CONTRACTOR's determination not to render payment to such Subcontractor or Supplier. Each progress payment application shall be accompanied by:

1. A conditional waiver and release upon progress payment pursuant to Civil Code Section 8132 for each Subcontractor and Supplier participating in the Work completed during the previous progress period which shall be in an amount no less than the dollar amount of such participation; and
2. A conditional waiver and release upon progress payment pursuant to Civil Code Section 8132 on behalf of the CONTRACTOR which shall be in an amount no less than the dollar amount of the total requested in the payment application.
3. Payment application, which includes a payment certification by the CONTRACTOR certifying that the Work for which payment is requested has been accomplished.

CONTRACTOR shall thereafter, within twenty (20) days of receipt of the payment from MCSD, complete an unconditional waiver and release upon progress payment pursuant to Civil Code Section 8134 for each Subcontractor and Supplier participating in the Work completed during the previous progress period and an unconditional waiver and release upon progress payment pursuant to Civil Code Section 8134 on behalf of the CONTRACTOR in an amount no less than the amount received from MCSD, and submit the same with CONTRACTOR's subsequent payment application.

7.2. PAYMENT – APPLICATIONS FOR PAYMENT

MCSD will not accept payment applications from the CONTRACTOR more frequently than once every four weeks. CONTRACTOR shall submit payment applications to MCSD addressed as follows:

Midway City Sanitary District
14451 Cedarwood Street
Westminster, CA 92863
Attention: Milo Ebrahimi, District Engineer

CONTRACTOR shall include the appropriate Project or Contract Number in the addressee information when submitting applications for payment to the ENGINEER.

Payment terms: net 30 days from receipt of properly submitted payment application.
CONTRACTOR's payment application shall include, at a minimum:

1. Clear reference to MCSD's Project or Contract number, as well as MCSD's Project title, to which the payment application applies.

2. CONTRACTOR's payment application number, payment application date, as well as the Contract payment number the invoice represents; for example, CONTRACTOR's submittal of its first payment application is payment number 1, its second payment application submittal is payment number 2, and so on. Any CONTRACTOR re-submittal/revision to a submitted payment application shall have a letter suffix (a, b, c, etc.) added to the payment number, signifying the payment application revision; for example, CONTRACTOR's first re-submittal of its first payment application shall be designated as payment for number "1a".
3. Clear reference to the payment schedule item(s) being invoiced and the appropriate milestone description of activities and/or Work related to the billing.
4. The itemized and total amount being invoiced (in U.S. dollars), less the amount of all contractual retention and deductions applicable for the invoiced amount (in U.S. dollars), and the resulting total net payment due.
5. The time period during which the Work was performed and for which the payment application is submitted.
6. Clear reference to the CONTRACTOR's Taxpayer ID Number.

7.3. CONTRACT PRICE ADJUSTMENTS AND PAYMENTS

A. General

1. Basis of Contract Price Adjustment – General

The basis of a Contract Price adjustment for any change to the Contract Documents, consisting of Extra Work, deletion or other revision shall be determined as specified herein.

For all changes to the Contract Documents that result in a Contract Price adjustment, the CONTRACTOR shall submit a cost and schedule proposal in the time and manner specified in the Contract Documents, including General Conditions sections Request for Change (Changes at CONTRACTOR's Request) and MCS D Initiated Changes. The CONTRACTOR's proposal must include a detailed cost breakdown itemizing all costs and schedule impacts associated with the Work, including material, labor, equipment, etc., all necessary back-up documentation to support said estimate, and any other data required by the ENGINEER. Delay by CONTRACTOR in submitting any pricing information required herein or negotiating in good faith with MCS D with regard to costs proposals for Extra Work, deletions or other revisions will result in delays in Contract Price adjustment and/or payment to CONTRACTOR, and MCS D shall not be responsible for any such delays or damages incurred by the CONTRACTOR as a result thereof. Also, the failure of the CONTRACTOR to submit any pricing information required herein or the failure to negotiate in good faith will prevent the Contract Price adjustment and/or payment to the CONTRACTOR, and

MCSD shall not be responsible for any such damages incurred by the CONTRACTOR as a result thereof.

Delays in negotiating an adjustment or in providing substantiating documentation may result in the issuance of a unilateral Change Order using MCSD's cost and schedule estimate.

Bilateral Change Order Execution. The execution of a bilateral Change Order is without reservation of right. The execution by MCSD and the CONTRACTOR shall be deemed to be an unconditional agreement to all Extra Work and adjustments to the Contract Price and Contract Duration related to the change.

No adjustments for Extra Work shall be valid unless submitted in writing by the CONTRACTOR and approved in writing by MCSD.

2. Allowable Costs for Extra Work – General

a. Credit Items.

Where the CONTRACTOR or any tier Subcontractor's portion of a change involves credit items or deductive changes, the CONTRACTOR shall utilize the same markups utilized for additive changes in computing the value of the credit. Contract Duration savings/impacts may also be addressed as appropriate to accurately reflect the nature and impact of the credit item or deductive change on the Work.

b. Performance and Payment Bond Costs.

Performance and Payment Bond costs associated with an adjustment shall be limited to the actual increase arising directly out of the Extra Work and will be paid upon receipt of surety premium invoice that is immediately due and payable by the CONTRACTOR. A copy of the Surety's invoice must be provided to document the change in cost of the Bonds.

c. Bid & Proposal Costs.

MCSD does not compensate for Bid preparation or cost and schedule proposal preparation costs.

B. Payment

1. Negotiated Price for Extra Work

a. General

MCSD will issue a Request for Proposal (RFP) requesting a cost and schedule proposal for the Extra Work in accordance with these General Conditions, MCSD

Initiated Changes. The CONTRACTOR's substantiated cost and schedule proposal, which shall conform to the requirements herein and the Section herein entitled MCS D Initiated Changes, must be provided within fifteen (15) days from issuance of a RFP in order to expedite negotiations. Alternatively, if the CONTRACTOR requests the change, the CONTRACTOR will submit a Request for Change which includes its substantiated cost and schedule proposal conforming to the requirements of the Section herein entitled Request for Change (Changes at CONTRACTOR's Request). MCS D may request that the CONTRACTOR certify the cost and schedule proposal. If warranted, MCS D may accept the CONTRACTOR's Bid price for lump sum or unit price amounts in the original or amended form and direct the CONTRACTOR to proceed with the Work. No costs for Extra Work shall be valid unless submitted in writing by the CONTRACTOR and approved in writing by MCS D.

b. Allowable Markup for Extra Work

The allowable markup for Extra Work performed by the CONTRACTOR and/or Subcontractor shall be determined in accordance with the provisions entitled, "Markup" herein, unless otherwise agreed to by MCS D.

2. Price for Extra Work on T&M Basis

When the price for the Extra Work cannot be agreed upon, MCS D may issue a unilateral change using its independent estimate and time impact analysis. MCS D may also direct such Work on a time and materials or force account basis.

Regarding allowable costs MCS D will use those identified above in Section A. MCS D will pay for the Extra Work based on the accumulation of allowable costs as provided herein.

3. Basis for Establishing Costs

a. Labor

The costs of labor will be the actual cost for wages of workers performing the Extra Work at the time the Extra Work is done, plus employer payments of payroll taxes, Worker's Compensation Insurance, liability insurance, health and welfare, pension, vacation, holiday, training, apprenticeship funds, and other direct costs, resulting from federal, state, or local laws, as well as assessments or benefits required by lawful collective bargaining agreements. Payroll taxes shall be calculated on base wage only and not on fringe benefits. Fringe benefits shall be applied only to the straight-time component of cost and shall not apply to the premium-time component unless otherwise required by the California Labor Code.

MCSD will reimburse Worker's Compensation Insurance costs for Extra Work labor at the pure premium rate approved by the California State Insurance Commissioner at the time the Extra Work is completed.

The use of a labor classification that would increase the Extra Work cost will not be permitted unless the CONTRACTOR establishes the necessity for such additional costs. Labor costs for equipment operators and helpers shall be submitted only when such costs are not included in the invoice for equipment rental. The labor cost for foremen shall be proportioned to all of their assigned Work and only that applicable to Extra Work will be paid.

Non-direct labor costs, including management personnel above foreman; office personnel (including clerical and other administrative staff); cost estimating; maintenance mechanics; incidental engineering and all other indirect costs of the Extra Work; and any other costs captured by CONTRACTOR's overhead costs, shall be considered part of markup specified in subsection below, and therefore are not recoverable as direct labor costs, unless the CONTRACTOR can demonstrate both that the costs (1) are not within the CONTRACTOR's overhead costs; and (2) occurred as part of or a direct result of the Extra Work.

Incidental engineering costs, referred to in the preceding paragraph, are considered non-direct labor costs, and include but are not limited to all time spent by engineers for RFI and RFC preparation, Change Order administration, preparation and coordination of shop drawings, attendance at meetings, inspections scheduling, estimating, drawing or manual preparation and revision, Claim preparation, submittal preparation and review, and mix and shoring design.

b. Materials

The cost of materials reported shall be at invoice or lowest current price at which such materials are locally available and delivered to the job site in the quantities involved, plus sales tax, freight, and delivery.

MCSD reserves the right to approve materials and sources of supply, or to supply materials to the CONTRACTOR if necessary for the progress of the Work. No markup shall be applied to any material provided by MCSD.

c. Tools and Equipment

CONTRACTOR-owned equipment charges for Extra Work, or for delays in Work, shall be in accordance with the current State of California, Department of Transportation, Division of Construction of Labor Surcharge and Equipment Rental Rates, as follows:

- i. Working Equipment Rates, 100% of the price listed for the first shift each day and at 50% of that same hourly rate for the second and third shifts each day.
- ii. Standby Equipment Rates, 50% of the price listed.

Tools and equipment rented by the CONTRACTOR will be reimbursed at the actual invoiced amount applicable to the Extra Work. The CONTRACTOR will provide the applicable weekly or monthly rate for tools and/or equipment that will be used in long durations.

No payment will be made for the use of tools or equipment that has a replacement value of \$500 or less.

The reported rental time for equipment already at the worksite shall be the duration of its use on the Extra Work. This time begins when equipment is first put into actual operation on the Extra Work, plus the time required to move it from its previous site and back, or to a closer site.

No payment will be made for use of CONTRACTOR-owned or rented transportation vehicles (including job trucks) unless the vehicle is utilized (1) by personnel at or below the foreman level; and (2) exclusively in connection with performing Extra Work. In such event, the CONTRACTOR will only be entitled to payment for the pro-rata time the vehicle was actually used in connection with the Extra Work, as properly documented and demonstrated by the CONTRACTOR. All other use of CONTRACTOR-owned or rented transportation vehicles shall be considered part of CONTRACTOR's markup specified in subsection below.

d. Other Items

MCSD may authorize other items that may be required on the Extra Work, including labor, services, material, and equipment. These items must be different in their nature from those required for the Work, and be of a type not ordinarily available for the CONTRACTOR or Subcontractors.

Invoices describing all such items in detail shall be submitted with the request for payment.

e. Invoices

Suppliers' invoices for material, equipment rental and other expenditures shall be submitted with the request for payment. If the request for payment is not substantiated by invoices or other documentation, MCSD may establish the cost of the item involved at the lowest price which was current at the time of the report.

f. General Conditions Costs

No increase in the General Conditions costs shall be allowed for Extra Work unless:

- i. such change extends the Contract Duration; or
- ii. CONTRACTOR demonstrates that an increase in actual General Conditions costs were incurred directly and solely as a result of the Extra Work.

4. Markup

a. Work by CONTRACTOR

The following percentages shall be added to the CONTRACTOR's costs and shall constitute the markup for all overhead and profits:

- i. Labor.....20%
- ii. Materials..... 15%
- iii. Equipment 15%
- iv. Other Items and Expenditures.....15%

b. Work by Subcontractor

Subcontractors performing all or any part of the Extra Work shall apply the same percentages identified in Subsection B.4.a. above, "Work by CONTRACTOR," which shall be added to the Subcontractor's costs and shall constitute the markup for all overhead and profits.

MCSD will pay the CONTRACTOR one (1) additional markup of 5% of the Subcontractor's compensation regardless of the number of intervening tiers of Subcontractors.

c. Contract Unit Prices

MCSD will not pay a markup for units with Unit Prices established in the Contract.

d. Other Costs Not Specifically Designated

The specified markups shall be deemed to include all items of expense not specifically designated and as substantiated as direct cost, indirect cost, or equipment rental in the Labor, Materials, Tools and Equipment, Other Items, and Invoices.

C. Daily Report by CONTRACTOR

When the price for the Extra Work cannot be agreed upon, the CONTRACTOR shall submit a daily report to the ENGINEER on forms approved by the ENGINEER. Included are applicable delivery tickets, listing all labor, materials, and equipment involved for the day, and other services and expenditures when authorized. Failure to submit the daily report by the close of the next working day may waive any rights for that day. An attempt shall be made to reconcile the report daily, and it shall be signed by the ENGINEER and the CONTRACTOR. In the event of disagreement, pertinent notes shall be entered by each party to explain points that cannot be resolved immediately. Each party shall retain a signed copy of the report. Reports by Subcontractors or others shall be submitted through the CONTRACTOR. MCS D will complete its final review of related costs after receipt of all records, and MCS D reserves its right to correct any errors in said records pertaining to Extra Work, including but not limited to cost found as a result of any such review.

The report shall:

1. Show names of workers, classifications, and hours worked.
2. Describe and list quantities of materials used.
3. Show type of equipment, size, identification number, and hours of operation, including loading, transportation, and stand-by time, if applicable.
4. Describe other services and expenditures in such detail as the ENGINEER may require.

D. Time & Material and Force Account Work

Work performed on a time and materials or force account basis will be subject to a Not to Exceed (NTE) amount. The CONTRACTOR is to provide written notification to the ENGINEER when it has expended seventy-five percent (75%) of the NTE amount. The notification must contain a cost and schedule proposal for the remaining Extra Work or an estimate to complete with an explanation as to why the remaining Extra Work cannot be priced. MCS D may negotiate a fixed price for the remaining Extra Work or if the remaining Extra Work cannot be priced, it may increase the NTE amount. If there is disagreement as to whether the remaining Extra Work can be priced, MCS D may issue a unilateral Change Order based on its independent estimate. In addition to the daily records the CONTRACTOR is required to submit in accordance with Subsection C “Daily Report by CONTRACTOR” above, if a CONTRACTOR seeks additional time arising from the Extra Work, the CONTRACTOR shall also submit all documents supporting any alleged time impacts and associated costs in the time and manner required by General Conditions Section entitled, “Extensions of time for Delay,” and in no event later than fifteen (15) days of completion of the Extra Work.

7.4. INCREASE OR DECREASE IN UNIT QUANTITIES

Increases or decreases in the quantity of a Unit (as defined herein as “a single item or group of items constituting a single unit which is identified as a Unit or Unit priced item in the Schedule of Prices”), as identified in the Schedule of Prices, will be determined by comparing, at the time of Final Completion, the actual or measured quantity of the Unit used to complete the Work with the estimated quantity of that Unit shown in the Schedule of Prices. If the actual or measured quantity of a Unit varies more than twenty-five percent (25%) above or below the estimated quantity of the Unit, an adjustment may be made upon demand of either party, and such adjustment will be made in accordance with these General Conditions, “Contract Price Adjustments and Payments.” In determining the adjustment to the Contract Price, the CONTRACTOR must, at a minimum, demonstrate its actual price of the Units, supported by documentation of Supplier/Subcontractor invoiced cost (not including overhead and profit). Said demand shall be made pursuant to these General Conditions, “OWNER Initiated Changes” and/or “Request for Change (Changes at CONTRACTOR’s Request).”

The adjustment shall be based upon any increase or decrease in costs due solely to the variations in quantity of the Unit as provided herein. This Section shall not apply to variations in quantity due to a Change Order. Furthermore, when the actual or measured quantity of a Unit required to complete the Work is more than a twenty-five percent (25%) increase from the estimated quantity of the Unit, as shown in the Schedule of Prices, the actual or measured quantity of Units up to one hundred twenty-five percent (125%) of the estimated quantity will be paid at the Contract Unit Price shown in the Schedule of Prices.

If neither party makes a demand for an adjustment in Contract Unit Price for actual or measured quantities above one hundred twenty-five percent (125%) or less than seventy-five percent (75%) of the estimated quantity, MCSD will pay the CONTRACTOR the Contract Unit Price shown in the Schedule of Prices for each such Unit.

7.5. SUSPENSION OF PAYMENTS

If after written notice to the CONTRACTOR of deficiencies in Work, failure to comply with the Contract, failure to comply with the Construction Schedule, or failure to revise and keep current with the Construction Schedule, the ENGINEER shall recommend that all or a portion of payments due or to become due under the Contract be suspended until the CONTRACTOR corrects any such deficiency; the ENGINEER may suspend said payments until such deficiencies are corrected.

7.6. MCSD’S RIGHT TO WITHHOLD CERTAIN AMOUNTS AND MAKE APPLICATION THEREOF

In addition to the amount which MCSD may retain pursuant to the General Conditions, including but not limited to the section entitled Retained Funds, MCSD may withhold a sufficient amount or amounts from any payment otherwise due to the CONTRACTOR as in its judgment may be necessary to cover:

1. Payments which may be past due and payable for properly filed claims against the CONTRACTOR or any Subcontractors for labor or materials furnished in or about the performance of the Work under this Contract.
2. Estimated or actual costs for correcting defective Work not remedied.
3. Amounts claimed by MCS D as forfeiture due to delays or other offsets to the Contract completion caused by the CONTRACTOR.
4. MCS D may contact the CONTRACTOR's Surety and make them aware of the Contract deficiencies, delays and other Contract non-conformance.

MCS D may apply such withheld amount or amounts to the payment of such claims at its discretion. In so doing, MCS D shall be deemed the agent of the CONTRACTOR and any payments so made by MCS D shall be considered as a payment made under the Contract by MCS D to the CONTRACTOR, and MCS D shall not be liable to the CONTRACTOR for such payment made in good faith. Such payments may be made without prior judicial determination of the claim or claims. MCS D will render to the CONTRACTOR a proper accounting of such funds disbursed on behalf of the CONTRACTOR.

7.7. STOP PAYMENT NOTICES

MCS D will, at its option and at any time, retain out of any amounts due the CONTRACTOR, sums sufficient to cover claims plus twenty-five percent (25%) filed pursuant to Section 9350 et. seq. of the Civil Code of the State of California. The CONTRACTOR shall pay to MCS D, or MCS D may deduct from any such payments made by MCS D to the CONTRACTOR, all costs and expenses including but not limited to administrative and legal expenses incurred by MCS D in processing and/or defending against stop payment notices. The CONTRACTOR will use MCS D's current forms for release of stop payment notices.

7.8. AUDIT ACCESS TO RECORDS

- A. The CONTRACTOR shall maintain all books, records, documents, and other evidence directly pertinent to the performance of the Work under this Contract in accordance with generally accepted accounting principles and practices consistently applied, consistent with those principles set forth in Part 31 of Federal Acquisition Regulation, Contract Cost Principles and Procedures. The CONTRACTOR shall also maintain all financial information and data used by the CONTRACTOR in the preparation or support of any cost submissions, including the CONTRACTOR's original Bid, required for this Contract, or any Change Order, Claim or other request for equitable adjustment, and a copy of the cost summary or information submitted to MCS D. MCS D authorized representatives shall have access, upon twenty four (24) hours advanced, written notice at all times during normal business hours, to all such books, records, documents, financial information, and all other evidence for the purpose of inspection, audit, and copying. The CONTRACTOR shall, at no cost to MCS D, provide proper facilities for such access, inspection, and copying purposes. In the event it is determined, by way of an audit or other means, that the

CONTRACTOR has been previously overpaid, MCS D shall have the right to deduct any such overpayment from the CONTRACTOR's next progress payment or the Final Payment, or the CONTRACTOR shall within 10 days after receiving notice from MCS D of any such overpayment reimburse MCS D in an amount equal to the overpayment, plus any applicable interest to which MCS D is entitled.

- B. The CONTRACTOR shall maintain cost accounting records, cost and pricing data and any other accounting evidence sufficient to properly reflect all direct and indirect costs of whatever nature pertaining the what CONTRACTOR has incurred, claims to have incurred, or anticipates it will incur in connection with the Contract Work and any and all Change Orders, Requests for Change and/or Claims, including but not limited to:
1. Direct costs of Contract item Work;
 2. Direct costs of changes and/or Extra Work in conformance with the provisions herein entitled Request for Changes (Changes at CONTRACTOR's Request), whether performed by the CONTRACTOR or others;
 3. Direct costs of changes and/or Extra Work in conformance with the provisions herein entitled or OWNER Initiated Changes, whether performed by the CONTRACTOR or others;
 4. Indirect costs of overhead.
- C. The CONTRACTOR agrees to make all items (A) through (H) of this section applicable to this Contract and all Change Orders, Claims, or other requests for equitable adjustments affecting the period of performance or price. The CONTRACTOR agrees to include items (A) through (H) of this section in all of the associated subcontracts and make these items applicable to all subcontracts, at any tier, in excess of \$10,000 and to make items (A) through (H) of this section applicable to all Change Orders, Claims, and other requests for equitable adjustment related to completion of the Work.
- D. Audits conducted under this Section shall be in accordance with generally accepted auditing standards and established procedures and guidelines of the reviewing or audit agency.
- E. The CONTRACTOR agrees to the disclosure of all information and reports resulting from access to records under items (A) through (H) of this section, to MCS D and other affected agencies.
- F. Records under Items (A) through (H) of the Section shall be maintained and made available during the performance of the Work under this Contract until 3 years past Final Payment, and until final settlement of all disputes, Claims, or litigation, whichever occurs later. In addition, those records which relate to any portion of this Contract, to any Change Order, to any dispute, to any litigation, to the settlement of any Claims arising out of such performance, or to costs or items to which an audit exception has been taken, shall be

maintained and made available until Final Payment or final resolution of such dispute, litigation, Claim, or exception, whichever occurs later.

G. This right of access article applies to all financial records pertaining to the Contract and all Change Orders. In addition, this right of access applies to all records pertaining to all contracts, Change Orders, and Contract amendments:

1. To the extent the records pertain directly to Contract performance;
2. If there is any indication that fraud, gross abuse, or corrupt practices may be involved;
or
3. If the CONTRACTOR's performance under the Contract is terminated for default or convenience.

H. Access to records is not limited to the required retention periods. The authorized representatives of MCS D shall have access to records at any reasonable time for as long as the records are maintained.

7.9. RETAINED FUNDS; SUBSTITUTION OF SECURITIES

From each progress payment MCS D shall retain five percent (5%) of the funds due the CONTRACTOR to assure satisfactory completion of the Contract. The cumulative amount retained as retention amounts shall be retained by MCS D until the Final Payment, and shall not exceed 5% of the Contract Price as amended or adjusted by Change Orders.

To ensure performance under the Contract Documents, the CONTRACTOR may, at its sole expense, substitute securities equivalent to the retention withheld by MCS D. Such securities shall be deposited with an escrow agent approved by MCS D, who shall then pay such retention to the CONTRACTOR. Upon satisfactory completion of the Work, the securities shall be returned to the CONTRACTOR. The CONTRACTOR shall be the beneficial owner of any security substituted for monies withheld and shall receive any accrued interest thereon. Securities eligible for investment shall include those listed in Government Code § 16430, bank or savings and loan certificates of deposit, interest bearing demand deposit accounts, standby letters of credit, or any other security mutually agreed to by the CONTRACTOR and MCS D. No such substitution shall be accepted until the escrow agreement, securities, and any other documents related to the substitution are executed by the CONTRACTOR and reviewed and accepted in writing by MCS D.

7.10. FINAL PAYMENT

CONTRACTOR shall, prior to Final Acceptance, prepare and submit an application for Final Payment to MCS D, in a form and manner approved by the ENGINEER.

The Final Payment including retention shall not be due and payable until after Final Acceptance occurs as more particularly set forth in Section "Final Completion and Final

Acceptance” herein, MCSD’S receipt of all documentation, records, and releases as required by the Contract and executed by the CONTRACTOR, and the expiration of thirty-five (35) days from the date of the recordation of Notice of Completion by MCSD.

If the CONTRACTOR fails to complete the Work as specified in the Contract Documents and if the unpaid balance of the Contract Price exceeds the direct and indirect costs of completing the Project, including, but not limited to, all costs generated to insure or bond the Work of substituted contractors or Subcontractors utilized to complete the Work, such excess shall be paid to CONTRACTOR. If such costs exceed the unpaid balance, CONTRACTOR shall pay the difference to MCSD promptly upon demand. On failure of CONTRACTOR to pay, the Surety shall pay on demand by MCSD. Any portion of such difference not paid by CONTRACTOR or Surety within thirty (30) days following the mailing of a demand for such costs by MCSD shall earn interest at the maximum rate authorized by California law.

It is mutually agreed between the parties to the Contract that no certificate given or payment made, under the Contract, shall be conclusive evidence of performance of the Contract, and no payment shall be construed to be an acceptance of any defective Work or improper materials.

The CONTRACTOR further agrees that the payment of the final amount due, under the Contract, and the adjustments and payments for any Work done in accordance with any alterations of the same, shall release MCSD, the Board of Directors and the CONSULTANT, and each of their directors, officers, employees, and agents, from any and all claims or liability on account of Work performed under the Contract or any alteration thereof.

8. MISCELLANEOUS

8.1. GOVERNING LAW

The Contract Documents have been negotiated between MCSD and the CONTRACTOR and shall be subject to and interpreted under the laws of the State of California.

By entering into the Contract, the CONTRACTOR consents and submits to the jurisdiction of the Courts of the State of California, County of Orange, over any action at law, suit in equity, and/or other proceeding that may arise out of the Contract Documents.

AGENDA ITEM #8C

Date: May 21, 2024

To: Board of Directors

From: Robert Housley, General Manager

Prepared by: Milo Ebrahimi, P.E., District Engineer

Subject: Consider Approval of a Professional Service Agreement with AKM Consulting Engineers for Preparation of Plans and Specifications for Construction of Manholes Upstream and Downstream of the Inverted Siphon at Westminster Boulevard and Springdale Street

BACKGROUND

The Midway City Sanitary District (District) owns an 8-inch diameter Vitrified Clay Pipe (VCP) sewer in Springdale Street, north of Westminster Boulevard, the most southerly reach of which extends from Manhole MH15030 and terminates at a manhole at the intersection of Westminster Boulevard and Springdale Street (MH15032). Until 1970, this sewer existed with a constant slope from Manhole MH15030 to Manhole MH15032. In 1970, the Orange County Sanitation District (OCSD) constructed the 60-inch diameter reinforced concrete Westminster Avenue Interceptor Sewer, which is located approximately 43 feet north of Manhole MH15032 at its crossing of District's 8-inch sewer. The OCSD's "As Constructed" plan for the Westminster Avenue Interceptor Sewer shows a 48-inch diameter manhole approximately 8 feet north of the centerline of their interceptor sewer and an inverted siphon with a length of 15 feet. Review of a CCTV recording (from 2014) of the 8-inch District sewer shows a vertical drop of approximately 2 feet. A CCTV recording of the section to the south of the interceptor sewer is not available, but it is reasonable to assume that a similar drop exists there as well.

The design of this inverted siphon does not meet any industry standards. There are no upstream and downstream manholes on either side of the siphon, the pipe does not descend and ascend with mild slopes, nor is there an air jumper, which are all essential elements for maintaining the siphon.

In March 2024, Empire Pipe Cleaning and Equipment, Inc. (Empire) was cleaning the section of the sewer from Manhole MH15023 northerly using a 6-inch skid nozzle, not being aware of the existence of the siphon. The nozzle dropped into the siphon. Empire retrieved the hose and the nozzle, and observed gravel, fines material, and broken pipe. Empire then used a 0.5" nozzle without a skid, in an attempt to clear the material. However, the smaller nozzle got stuck in the pipe approximately 40 feet north of Manhole MH15032, which is very close to the interceptor sewer. Empire could not retrieve the nozzle, and cut the attached hose at Manhole 15032. It is assumed that the nozzle got stuck at the 90 degree bend at the bottom of the siphon. It is evident that the hose and the nozzle are plugging the pipes, which results in the sewage backing up in the upstream (northerly) sewer up to Manhole MH14028 at the intersection of Navajo Street and Sioux Road. The flow is now being conveyed westerly and northerly in Meinhardt Road to a crossing of the 405 Freeway between Allison Circle and White Circle, then in Hammon Place to the Hammon Lift

Station. Staff believes there is now something wrong with the siphon and it may even be partially collapsed.

DISCUSSION

Eventually, a new siphon parallel to the existing one will need to be constructed. However, that process will take additional time to design, get permitted, bid, and constructed. It is proposed that the District construct manholes upstream and downstream of the existing siphon and attempt to remove the nozzle and hose stuck in it, establishing the conditions prior to March 2024.

To prepare the construction plans and specification to establish the conditions prior to March 2024, the following action is required by a consultant engineering firm:

1. Conduct field surveying to determine the invert elevations of various sewers at nine (9) manholes.
2. Obtain as-built plans of the utilities at the Westminster Boulevard and Springdale Street intersection and in Springdale Street north of the intersection.
3. Conduct field review of the project site and compare the as-built utility information to the USA marked utilities in the area.
4. Select locations of the upstream (north) and downstream (south) manholes.
5. Prepare plans, profiles and details, as well as specifications for the project, including front end documents utilizing District standards.
6. Conduct geotechnical investigation with one boring to develop recommendations for shoring and dewatering for the manhole, as well as future parallel inverted siphon design.
7. Contact the City of Westminster and OCSD to identify permit requirements.
8. Submit the plans and specifications to District, OCSD and the City of Westminster for review and comments.
9. Address the comments, revise the plans and specifications, and submit for final approval.
10. Prepare the final bid-ready contract documents.
11. Provide bidding support services.
12. Provide engineering services during construction, including as-built plans.

It is anticipated it will take approximately 3 months to complete items 1-10 so that the District will be in a position commence the bidding process for the construction contract.

Staff has obtained a proposal from AKM Consulting Engineers (AKM) for preparation of plans and specifications for construction of this project. Although the District's Purchasing Policy and Procedures contemplate a formal RFP process for professional services agreements over \$40,000, Staff believes the urgent nature of the work and other factors justify the Board's waiver of a formal procurement process in this case. Staff believes by selecting AKM for this project, the District will save time and money and be in a position to go out to award a contract for construction of the manholes sooner than if it undertook a formal RFP process for the design work.

Staff believes the District will save time, which is crucial for this project. The District's Sewer System can handle the dry season load. But Staff is not sure if the system could handle the load during the wet season with the siphon issue. If the system cannot handle the load, there is a possibility of sewer overflow. Since AKM is already working on SSMP, they already have most

of the information that they need for this project; therefore, AKM could save time on this project compared to any other consultant. The following parts of the scope for the SSMP project would be used for the design of this project:

1. Sewer System Evaluation Criteria
2. Hydraulic Model and Calibration
3. Sewer Hydraulic Model Analyses
4. Sewer Lift Station Assessments
5. Capital Improvement Program

Staff believes the District will also save money if AKM is selected to work on this project. Staff believes that AKM could finish this project faster and more efficiently compared to another consultant since they are already working on SSMP project. AKM has a group of experienced engineers that are suitable for similar projects. Therefore, AKM would spend less time to successfully accomplish this project. By saving time, District will save money on this project and be able to bid a contract for construction sooner.

The District has worked with AKM on several different projects, and the District has always had a good experience and good relationship with this consulting firm.

Section 11 of the District's Purchasing Policy and Procedures authorizes the Board to waive the requirements of the Policy on a case-by-case basis and direct the procurement of services through Negotiate Procurement. Pursuant to Section 11.B of the Purchasing Policy and Procedures, Negotiated Procurements are permitted in a variety of circumstances, including "where competitive bidding would be impossible, impractical, or incongruous, or would not result in any advantage to the District in its efforts to contract for the greatest public benefit;" "in an emergency;" and "where compelling economic or administrative considerations warrant employment of alternate purchasing procedures," including "circumstances in which services have been previously rendered by a Contractor who has thereby gained and exhibited unique and/or superior experience and/or expertise in relation to the District's operational requirements." Staff believes the circumstances warrant waiver of the formal RFP process in this case.

The proposal obtained from AKM includes the engineering and design work necessary to prepare bid-ready contract documents, as well bidding support services, and engineering services during construction, including preparation of the as-built plans. General Counsel has prepared a proposed Professional Services Agreement with AKM for the Board's consideration. Under the proposed Agreement, AKM would provide its services on a time and materials basis based on rates set forth in its Proposal, up to the estimated total cost of \$119,164. AKM would be required to immediately notify the District if it anticipates the cost of its work will exceed this amount and would need to get written approval of the District before exceeding this estimated maximum contract amount.

FISCAL IMPACT

Total fiscal impact is estimated to be approximately \$119,164.00 from Sewer Engineering and Consulting Account, Account Number 7725.20.

STAFF RECOMMENDATION

Staff recommends that the Board of Directors (1) waive the formal procurement requirements for professional services and authorize a negotiated procurement; (2) approve the proposed Professional Services Agreement between the District and AKM Consulting Engineers for preparation of plans and specifications for construction of Manholes Upstream and Downstream of the Inverted Siphon at Westminster Boulevard and Springdale Street; (3) authorize the General Manager to make minor changes to the Agreement as needed and to execute the Agreement on behalf of the District; and (4) authorize the General Manager to approve services or work costing up to \$15,000 more than the Estimated Maximum Contract amount of \$119,164 pursuant to Section 3.1 of the Agreement, if necessary.

ATTACHMENTS:

1. Professional Services Agreement with AKM Consulting Engineers

PROFESSIONAL SERVICES AGREEMENT

AKM Consulting Engineers

(Preparation of Plans and Specifications for Construction of Manholes Upstream and Downstream of the Inverted Siphon at Westminster Boulevard and Springdale Street)

THIS PROFESSIONAL SERVICES AGREEMENT (hereinafter “Agreement”) is made this 21st day of May, 2024, by the MIDWAY CITY SANITARY DISTRICT, a public entity (hereinafter referred to as “DISTRICT”) and AKM CONSULTING ENGINEERS, California corporation, (hereinafter referred to as “CONTRACTOR”). DISTRICT and CONTRACTOR are sometimes hereinafter individually referred to as “Party” and are hereinafter collectively referred to as the “Parties.”

RECITALS

The following recitals are a substantive part of this Agreement:

- A. This Agreement is entered into pursuant to authorization of the Midway City Sanitary District Board of Directors, dated May 21, 2024.
- B. DISTRICT has determined there is a need to retain the professional services of a qualified company to provide the DISTRICT with engineering design services to prepare plans and specifications for construction of manholes upstream and downstream of the inverted siphon at Westminster Boulevard and Springdale Street, related bidding support services, and engineering services during construction (the “Project”).
- C. CONTRACTOR has submitted to DISTRICT a proposal, dated May 10, 2024, to provide DISTRICT with professional services to complete the Project (the “Proposal”).
- D. CONTRACTOR represents and maintains that it is uniquely qualified by virtue of its experience, training, education, reputation, and technical expertise to provide professional services to DISTRICT for the Project and has agreed to provide such services as provided herein. DISTRICT does not have the personnel, training, certification, or specialized technical expertise necessary to perform the work and services contracted for herein.
- E. DISTRICT desires to retain CONTRACTOR to provide professional services for the Project.

AGREEMENT

THE PARTIES MUTUALLY AGREE AS FOLLOWS:

1. **Term and Termination.** This Agreement shall cover services rendered from the full execution of this Agreement through completion of the tasks outlined in CONTRACTOR’s Proposal, unless earlier terminated by DISTRICT. This Agreement may be terminated by

DISTRICT without cause upon thirty (30) days written notice. In such event, the DISTRICT will compensate CONTRACTOR for work performed to date in accordance with Section 3.4 of this Agreement. CONTRACTOR is required to present evidence to support performed work completion. CONTRACTOR is required to present evidence to support performed work completion.

2. Services to be Provided and Standard of Performance.

2.1 Scope of Services. In compliance with all terms and conditions of this Agreement, CONTRACTOR agrees to provide and perform professional engineering design services to prepare plans and specifications for construction of manholes upstream and downstream of the inverted siphon at Westminster Boulevard and Springdale Street, related bidding support services, and engineering services during construction, as set forth in the Proposal, which is attached hereto as Exhibit "A" and incorporated herein by reference (hereinafter referred to as the "Scope of Services," the "Services" or "Work"). As a material inducement to DISTRICT entering into this Agreement, CONTRACTOR acknowledges and understands that the Services and Work contracted for under this Agreement require specialized skills and abilities and that, consistent with this understanding, CONTRACTOR's Services and Work shall be performed in a skillful and competent manner and shall be held to a standard of quality and workmanship prevalent in the industry for such Services and Work and with the standards recognized as being employed by professionals in the same discipline in the State of California. CONTRACTOR represents and warrants that it is skilled in the professional discipline necessary to perform the Services and Work and that it holds the necessary skills and abilities to satisfy the standard of work as set forth in this Agreement. CONTRACTOR represents and warrants that it and all of its employees, subconsultants and subcontractors providing any Work or Services under this Agreement shall have sufficient skill and experience to perform the Services and Work assigned to them. All Services and Work shall be completed to the reasonable satisfaction of DISTRICT. The Proposal, the Request for Proposals, and this Agreement do not guarantee any specific amount of work.

2.2 Contract Documents. The Agreement between the Parties shall consist of the following: (1) this Agreement; and (2) the Proposal submitted to the DISTRICT, which shall both be referred to collectively hereinafter as the "Contract Documents." The CONTRACTOR's Proposal is attached hereto as Exhibit "A" and is hereby incorporated by reference and made a part of this Agreement. All provisions of the Contract Documents shall be binding on the Parties. Should any conflict or inconsistency exist in the Contract Documents, the conflict or inconsistency shall be resolved by applying the provisions in the highest priority document, which shall be determined in the following order of priority: (1st) the terms and conditions of this Agreement; and, (2nd) the provisions of the CONTRACTOR's Proposal (Exhibit "A").

2.3 Compliance with Law. CONTRACTOR shall comply at all times during the term of this Agreement with all applicable laws, ordinances, codes, and regulations of the federal, state, and local government, including without limitation all applicable fair labor standards and Cal/OSHA requirements. CONTRACTOR shall keep itself fully informed of and in compliance with all local, state, and federal laws, rules, and regulations in any manner affecting the performance of the Work and Services, including all Cal/OSHA requirements, and shall give all notices required by law. CONTRACTOR shall be liable for all violations of such laws and

regulations in connection with performing the Work and Services. If CONTRACTOR performs any Work or Services in violation of such laws, rules, and regulations, CONTRACTOR shall be solely responsible for all penalties and costs arising therefrom. CONTRACTOR shall defend, indemnify, and hold DISTRICT, its officials, officers, employees, agents and volunteers, free and harmless from any claim or liability arising out of any failure or alleged failure to comply with such laws, rules, or regulations.

2.4 Licenses, Permits, and Fees. Prior to performing any Services or Work hereunder CONTRACTOR shall obtain all licenses, permits, qualifications, and approvals of whatever nature that are legally required to practice its profession and perform the Work and Services required by this Agreement. CONTRACTOR represents and warrants to DISTRICT that CONTRACTOR shall, at its sole cost and expense, keep in effect at all times during the term of this Agreement and any extension, any license, permit, qualification, or approval that is legally required for CONTRACTOR to perform the Work and Services under this Agreement. CONTRACTOR shall have the sole obligation to pay for any fees, assessments, and taxes, plus applicable penalties and interest, which may be imposed by law and arise from or are necessary for the CONTRACTOR's performance of the Work and Services required by this Agreement, and shall defend, indemnify, and hold DISTRICT, its officials, officers, employees, agents and volunteers, free and harmless from and against any claim or liability arising out of any failure or alleged failure to obtain such license, permits, and approvals of whatever nature that are legally required to perform the Work or Services.

2.5 Familiarity with Work. By executing this Agreement, CONTRACTOR warrants that: (1) it has thoroughly investigated and considered the Scope of Work or Services to be performed; (2) it has carefully considered how the Services should be performed and has carefully examined the location or locations at or with respect to where such Services or Work is to be performed and is aware of all conditions there; and (3) it understands the facilities, difficulties, and restrictions of attending performance of the Services under this Agreement. If the Services involve work upon any site, CONTRACTOR represents and maintains that CONTRACTOR has or will investigate the site and is or will be fully acquainted with the conditions there existing, prior to commencement of any Services hereunder. Should CONTRACTOR discover any latent or unknown conditions materially differing from those inherent in the Work or as represented by DISTRICT, it shall immediately inform DISTRICT of this and shall not proceed, except at CONTRACTOR's risk, until written instructions are received from DISTRICT.

2.6 Care of Work. CONTRACTOR shall adopt reasonable methods during the term of the Agreement to furnish continuous protection to the Work and the equipment, materials, papers, documents, plans, studies, and/or other components thereof to prevent losses or damages, and shall be responsible for all such damages, to persons or property, until acceptance of the Work by DISTRICT, except such losses or damages as may be caused by DISTRICT's own negligence.

2.7 Further Responsibilities of Parties. Both Parties agree to use reasonable care and diligence to perform their respective obligations under this Agreement. Both Parties agree to act in good faith to execute all instruments, prepare all documents, and take all actions as may be reasonably necessary to carry out the purposes of this Agreement.

3. Compensation.

3.1 Contract Amount. For the Services and Work rendered pursuant to this Agreement, CONTRACTOR shall be compensated by DISTRICT for the Services performed, including authorized reimbursements, on a time and materials basis in accordance with the professional rates and charges set forth in the Proposal (Exhibit "A"). CONTRACTOR estimates that the total cost to complete the Project will not exceed the total estimated maximum contract amount of One Hundred Nineteen Thousand One Hundred Sixty-Four Dollars and 00/100 cents (\$119,164.00) (hereinafter referred to as the "Estimated Maximum Contract Amount"). If CONTRACTOR anticipates that the Work to complete the Project will cause the Estimated Maximum Contract Amount to be exceeded, it shall immediately provide written notice to DISTRICT and provide an updated estimate of the total cost of the Services and Work it anticipates will be required to complete the Project. CONTRACTOR shall not perform Services or Work costing more than the Estimated Maximum Contract Amount without prior written approval of the DISTRICT. Compensation for necessary expenditures for reproduction costs, telephone expenses, and transportation expenses must be approved in advance by the DISTRICT and will only be approved if such expenses are also specified in the Proposal.

3.2 Payment. For Work or Services under this Agreement, payment shall be made in arrears per invoice for Work completed, subject to the payment provisions set forth in the Proposal (Exhibit "A"). CONTRACTOR shall submit to DISTRICT monthly or periodic statements requesting payment. Such requests shall be based upon the amount and value of the Services performed by CONTRACTOR under this Agreement and shall be prepared by CONTRACTOR and accompanied by such reporting data including a detailed breakdown of all costs incurred and tasks performed during the period covered by the statement, as may be required by DISTRICT. Invoices shall be submitted on or about the first business day of each month, for Services provided the prior month. DISTRICT shall use reasonable efforts to make payment to CONTRACTOR within forty-five (45) days after the date of the invoice or as soon thereafter as reasonably practicable.

3.3 Changes in Scope. In the event any change or changes in the Scope of Services is requested by DISTRICT and agreed to by CONTRACTOR, the Parties shall execute a written amendment to this Agreement, setting forth with particularity all terms of such amendment, including, but not limited to, any additional fees.

3.4 Termination. DISTRICT shall have the right to terminate this Agreement, without cause, by giving thirty (30) days written notice of termination. If the Agreement is terminated by DISTRICT, then the provisions of paragraph 3 would apply to that portion of the work completed.

3.5 Appropriations. This Agreement is subject to and contingent upon funds being appropriated therefore by the Midway City Sanitary District Board of Directors for each fiscal year covered by the term of this Agreement. If such appropriations are not made, this Agreement shall automatically terminate without penalty to DISTRICT.

4. **Insurance requirements.**

4.1 **Commencement of Work.** CONTRACTOR shall not commence work under this Agreement until all certificates and endorsements have been received and approved by the DISTRICT. All insurance required by this Agreement shall contain a Statement of Obligation on the part of the carrier to notify the DISTRICT of any material change, cancellation, or termination at least thirty (30) days in advance.

4.2 **Workers Compensation Insurance.** During the duration of this Agreement, CONTRACTOR and all subcontractors shall maintain Workers Compensation Insurance in the amount and type required by law, if applicable.

4.3 **Insurance Amounts.** CONTRACTOR and all subcontractors shall procure and maintain insurance acceptable to DISTRICT. Unless otherwise agreed or waived in writing by DISTRICT's General Manager, CONTRACTOR and all subcontractors shall maintain the following insurance for the duration of this Agreement:

(a) Commercial general liability in an amount of \$2,000,000.00 per occurrence: **claims made and modified occurrence policies are not acceptable**; Insurance companies must be acceptable to DISTRICT and have a Best's Guide Rating of A- Class VII or better, as approved by the DISTRICT.

(b) Automobile liability in an amount of \$1,000,000.00 combined single limit: **claims made and modified occurrence policies are not acceptable**; Insurance companies must be acceptable to DISTRICT and have a Best's Guide Rating of A- Class VII or better, as approved by the DISTRICT.

(c) Professional negligence errors and omissions in an amount not less than \$1,000,000 per claim or occurrence. Insurance companies must be admitted and licensed In California and have a Best's Guide Rating of A-, Class VII or better, as approved by the DISTRICT. If the policy is written on a "claims made" basis, the policy shall be continued in full force and effect at all times during the term of the agreement, and for a period of three (3) years from the date of the completion of services provided. In the event the policy is written on an "occurrence" basis, the policy shall be continued in full force and effect during the term of this Agreement, or until completion of the Services provided for in this Agreement, whichever is later. In the event of termination, cancellation, or material change in the policy, CONTRACTOR shall obtain continuing insurance coverage for the prior acts or omissions of CONTRACTOR during the course of performing Services under the term of the Agreement. The coverage shall be evidenced either by a new policy evidencing no gap in coverage, or by obtaining separate extended "tail" coverage with the present or new carrier.

An **On-Going and Completed Operations Additional Insured Endorsement** for the policy under section 4.3 (a) shall designate DISTRICT, its officers, officials, employees, agents, and volunteers as additional insureds for liability arising out of work or operations performed by or on behalf of the CONTRACTOR. CONTRACTOR shall provide to DISTRICT proof of insurance

and endorsement forms that conform to DISTRICT's requirements, as approved by the DISTRICT.

An Additional Insured Endorsement for the policy under section 4.3 (b) shall designate DISTRICT, its officers, officials, employees, agents, and volunteers as additional insureds for automobiles, owned, leased, hired, or borrowed by the CONTRACTOR. CONTRACTOR shall provide to DISTRICT proof of insurance and endorsement forms that conform to DISTRICT's requirements, as approved by the DISTRICT.

For any claims related to this Agreement, CONTRACTOR's insurance coverage shall be primary insurance as respect to DISTRICT, its officers, officials, employees, agents, and volunteers. Any insurance or self-insurance maintained by the DISTRICT, its officers, officials, employees, agents, and volunteers shall be excess of the CONTRACTOR's insurance and shall not contribute with it.

If CONTRACTOR maintains higher insurance limits than the minimums shown above, CONTRACTOR shall provide coverage for the higher insurance limits otherwise maintained by the CONTRACTOR.

5. Non-Liability of Officials and Employees of the District. No official or employee of DISTRICT shall be personally liable to CONTRACTOR in the event of any default or breach by DISTRICT, or for any amount which may become due to CONTRACTOR.

6. Conflict of Interest. No officer or employee of the DISTRICT shall have any financial interest, direct or indirect, in this Agreement nor shall any such officer or employee participate in any decision relating to the Agreement which effects his or her financial interest or the financial interest of any corporation, partnership, or association in which they are, directly or indirectly, interested in violation of any state statute or regulation. CONTRACTOR represents and warrants that it has not paid or given and will not pay or give any third party any money or other consideration in exchange for obtaining this Agreement.

7. Covenant Against Discrimination. In connection with its performance under this Agreement, CONTRACTOR shall not discriminate against any employee or applicant for employment because of race, disability, medical condition, religion, color, sex, sexual orientation, age, marital status, ancestry, or national origin. CONTRACTOR shall ensure that applicants are employed, and that employees are treated during their employment, without regard to their race, disability, medical condition, religion, color, sex, sexual orientation, age, marital status, ancestry, or national origin. Such actions shall include, but not be limited to, the following: employment, upgrading, demotion or transfer; recruitment or recruitment advertising; layoff or termination; rates of pay or other forms of compensation; and selection for training, including apprenticeship.

8. Independent Contractor.

(a) The legal relationship between the Parties is that of an independent contractor, and nothing herein shall be deemed to make CONTRACTOR a DISTRICT employee. During the performance of this Agreement, CONTRACTOR and its officers, employees, and agents shall act in an independent capacity and shall not act as DISTRICT officers or employees. CONTRACTOR will determine the means, methods and details of performing the Services subject to the requirements of this Agreement. The personnel performing the Services under this Agreement on behalf of CONTRACTOR shall at all times be under CONTRACTOR's exclusive direction and control. Neither DISTRICT nor any of its officials, officers, employees, agents or volunteers shall have control over the conduct of CONTRACTOR or any of its officers, employees, or agents, except as set forth in this Agreement. CONTRACTOR, its officers, employees or agents, shall not maintain a permanent office or fixed business location at DISTRICT's offices. DISTRICT shall have no voice in the selection, discharge, supervision, or control of CONTRACTOR's officers, employees, representatives or agents or in fixing their number, compensation, or hours of service. CONTRACTOR shall pay all wages, salaries, and other amounts due its employees in connection with the performance of Services under this Agreement and shall be responsible for all reports and obligations respecting them, including but not limited to social security income tax withholding, unemployment compensation, workers' compensation, and other similar matters. DISTRICT shall not in any way or for any purpose be deemed to be a partner of CONTRACTOR in its business or otherwise a joint venturer or a member of any joint enterprise with CONTRACTOR.

(b) CONTRACTOR shall not incur or have the power to incur any debt, obligation, or liability against DISTRICT, or bind DISTRICT in any manner.

(c) No DISTRICT benefits shall be available to CONTRACTOR, its officers, employees, or agents, in connection with the performance of any Work or Services under this Agreement. Except for professional fees paid to CONTRACTOR as provided for in this Agreement, DISTRICT shall not pay salaries, wages, or other compensation to CONTRACTOR for the performance of any Work or Services under this Agreement. DISTRICT shall not be liable for compensation or indemnification to CONTRACTOR, its officers, employees, or agents, for injury or sickness arising out of performing any Work or Services hereunder. If for any reason any court or governmental agency determines that the DISTRICT has financial obligations, other than pursuant to Section 3 herein, of any nature relating to salary, taxes, or benefits of CONTRACTOR's officers, employees, representatives, agents, or subconsultants or subcontractors, CONTRACTOR shall defend, indemnify, and hold harmless DISTRICT from and against all such financial obligations.

9. Notices. All notices shall be personally delivered or mailed to the below listed address, or to such other addresses as may be designated by written notice, and shall be deemed received upon the earlier of (i) the date of delivery to the address of the person to receive such notice if delivered personally or by messenger or overnight courier; or (ii) five (5) business days after the date of posting by the United States Post Office if by mail. These addresses shall be used for delivery of service of process.

(CONTRACTOR) AKM Consulting Engineers
Attn: Zeki Kayiran
553 Wald
Irvine, CA 92618

(DISTRICT) Midway City Sanitary District
Attention: Director of Services and Program Development
14451 Cedarwood Street
Westminster, CA 92863

(WITH COPY TO) Midway City Sanitary District
Attention: General Counsel
14451 Cedarwood Street
Westminster, CA 92863

10. Schedule of Performance.

10.1 Time of Essence. Time is of the essence in the performance of this Agreement. The time for completion of the Services to be performed by CONTRACTOR is an essential condition of this Agreement. CONTRACTOR shall prosecute regularly and diligently the Services according to the agreed upon Schedule of Performance.

10.2 Schedule of Performance. CONTRACTOR shall commence the Services pursuant to this Agreement upon receipt of a written notice to proceed, or on each task order, if applicable, and shall perform all Services within the time period(s) established in the Schedule of Performance set forth in the Proposal (Exhibit "A"), or otherwise mutually agreed upon by the Parties. When requested by CONTRACTOR, extensions to the time period(s) specified in the Schedule of Performance may be approved in writing by the DISTRICT; however, the DISTRICT shall not be obligated to grant such an extension.

10.3 Force Majeure. The time period(s) specified in the Schedule of Performance for performance of the Services rendered pursuant to this Agreement shall be extended because of any delays due to unforeseeable causes beyond the control and without the fault or negligence of the CONTRACTOR (financial inability excepted), including, but not limited to, acts of God or of the public enemy, unusually severe weather, fires, earthquakes, floods, epidemics, pandemics, quarantine restrictions, riots, strikes, freight embargoes, wars, and/or acts of any governmental agency, including the DISTRICT, if CONTRACTOR, within ten (10) days of the commencement of such delay, notifies the DISTRICT's General Manager in writing of the causes of the delay. The General Manager shall ascertain the facts and the extent of delay, and extend the time for performing the Services for the period of the enforced delay when and if in the judgment of the General Manager such delay is justified. The General Manager's determination shall be final and conclusive upon the Parties to this Agreement. In no event shall CONTRACTOR be entitled to recover damages against the DISTRICT for any delay in the performance of this Agreement, however caused, CONTRACTOR's sole remedy being extension of the Agreement pursuant to this section.

11. Limitations Upon Subcontracting and Assignment. The experience, knowledge, capability, and reputation of CONTRACTOR, its principals and employees were a substantial inducement for DISTRICT to enter into this Agreement. CONTRACTOR shall not contract with any other entity to perform the services required without written approval of the DISTRICT. This Agreement may not be assigned voluntarily or by operation of law, without the prior written approval of DISTRICT. If CONTRACTOR is permitted to subcontract any part of this Agreement, CONTRACTOR shall be responsible to DISTRICT for the acts and omissions of its subcontractor as it is for persons directly employed. Nothing contained in this Agreement shall create any contractual relationship between any subcontractor and DISTRICT. All persons engaged in the work will be considered employees of CONTRACTOR. DISTRICT will deal directly with and will make all payments to CONTRACTOR.

12. Indemnification. To the fullest extent permitted by law, CONTRACTOR shall indemnify, defend (at CONTRACTOR's sole cost and expense), protect and hold harmless the Midway City Sanitary District and its board members, officers, officials, employees, agents, and volunteers, (individually "Indemnified Party"; collectively "Indemnified Parties") against any and all liability, claims, judgments, costs, and demands (collectively, "Claims"), including Claims arising from injuries or death of persons (CONTRACTOR's employees included) and damage to property, which Claims arise out of, pertain to, or are related to the negligence, recklessness or willful misconduct of CONTRACTOR, its agents, employees, or subcontractors, or arise from CONTRACTOR's negligent, reckless or willful performance of or failure to perform any term, provision, covenant or condition of this Agreement ("Indemnified Claims"), but CONTRACTOR's liability for Indemnified Claims shall be reduced to the extent such Claims arise from the negligence, recklessness or willful misconduct of the DISTRICT and its board members, officers, directors, officials, employees, or agents.

CONTRACTOR shall reimburse the Indemnified Parties for any reasonable expenditures, including reasonable attorneys' fees, expert fees, litigation costs and expenses that each Indemnified Party may incur by reason of Indemnified Claims. Upon request by an Indemnified Party, CONTRACTOR will defend with legal counsel reasonably acceptable to the Indemnified Party all Claims against the Indemnified Party that may arise out of, pertain to, or relate to Indemnified Claims, whether or not CONTRACTOR is named as a party to the Claim proceeding. The determination whether a Claim may "arise out of, pertain to, or relate to" Indemnified Claims shall be based on the allegations made in the Claim and the facts known or subsequently discovered by the parties. In the event a final judgment, arbitration award, order, settlement, or other final resolution expressly determines that Claims did not arise out of, pertain to, nor relate to the negligence, recklessness or willful misconduct of Consultant to any extent, then DISTRICT will reimburse CONTRACTOR for the reasonable costs of defending the Indemnified Parties against such Claims, except DISTRICT shall not reimburse CONTRACTOR for attorneys' fees, expert fees, litigation costs and expenses as were incurred defending CONTRACTOR or any parties other than Indemnified Parties against such Claims.

CONTRACTOR'S liability for indemnification hereunder is in addition to any liability CONTRACTOR may have to DISTRICT for a breach by CONTRACTOR of any of the provisions of this Agreement. Under no circumstances shall the insurance requirements and limits set forth in this Agreement be construed to limit CONTRACTOR'S indemnification obligation or other

liability hereunder. The terms of this Agreement are contractual and the result of negotiation between the parties hereto. Accordingly, any rule of construction of contracts (including, without limitation, California Civil Code Section 1654) that ambiguities are to be construed against the drafting party, shall not be employed in the interpretation of this Agreement.

CONTRACTOR'S indemnification obligation hereunder shall survive the expiration or earlier termination of this Agreement until all actions against the Indemnified Parties for such matters indemnified hereunder are fully and finally barred by the applicable statute of limitations or, if an action is timely filed, until such action is final. This provision is intended for the benefit of third party Indemnified Parties not otherwise a party to this Agreement.

13. Reports.

(a) Each and every report, draft, work product, map, record and other document, hereinafter collectively referred to as "Report", reproduced, prepared or caused to be prepared by CONTRACTOR pursuant to or in connection with this Agreement, shall be the exclusive property of DISTRICT. CONTRACTOR shall not copyright any Report required by this Agreement and shall execute appropriate documents to assign to District the copyright to Reports created pursuant to this Agreement. Any Report, information and data acquired or required by this Agreement shall become the property of DISTRICT, and all publication rights are reserved to DISTRICT.

(b) All Reports prepared by CONTRACTOR may be used by DISTRICT in execution or implementation of:

- (1) The original Project for which CONTRACTOR was hired;
- (2) Completion of the original Project by others;
- (3) Subsequent additions to the original Project; and/or
- (4) Other DISTRICT projects as appropriate.

(c) No Report, information or other data given to or prepared or assembled by CONTRACTOR pursuant to this Agreement shall be made available to any individual or firm by CONTRACTOR without prior approval by District.

14. Reserved.

15. Waiver. No waiver of any provision of this Agreement shall be effective unless in writing and signed by a duly authorized representative of the Party against whom enforcement of a waiver is sought. Any waiver by the Parties of any default or breach of any covenant, condition, or term contained in this Agreement, shall not be construed to be a waiver of any subsequent or other default or breach, nor shall failure by the Parties to require exact, full, and complete compliance with any of the covenants, conditions, or terms contained in this Agreement be construed as changing the terms of this Agreement in any manner or preventing the Parties from enforcing the full provisions hereof.

16. **Rights and Remedies Cumulative.** Except with respect to rights and remedies expressly declared to be exclusive in this Agreement, the rights and remedies of the Parties are cumulative and the exercise by either Party of one or more of such rights or remedies shall not preclude the exercise by it, at the same or different times, of any other rights or remedies for the same default or any other default by the other Party.

17. **Legal Action.** In addition to any other rights or remedies, either Party may take legal action, in law or in equity, to cure, correct or remedy any default, to recover damages for any default, to compel specific performance of this Agreement, to obtain declaratory or injunctive relief, or to obtain any other remedy consistent with the purposes of this Agreement.

18. **California Law; Venue.** This Agreement shall be construed in accordance with the laws of the State of California. Any action commenced about this Agreement shall be filed in the central branch of the Orange County Superior Court.

19. **Interpretation.** This Agreement shall be construed as a whole according to its fair language and common meaning to achieve the objectives and purposes of the Parties. The terms of this Agreement are contractual and the result of negotiation between the Parties. Accordingly, any rule of construction of contracts (including, without limitation, California Civil Code Section 1654) that ambiguities are to be construed against the drafting party, shall not be employed in the interpretation of this Agreement. The caption headings of the various sections and paragraphs of this Agreement are for convenience and identification purposes only and shall not be deemed to limit, expand, or define the contents of the respective sections or paragraphs.

20. **Entire Agreement; Modification.** This Agreement constitutes the entire agreement between the parties and supersedes any previous agreements, oral or written. This Agreement may be modified only by subsequent mutual written agreement executed by DISTRICT and CONTRACTOR.

21. **Severability.** Whenever possible, each provision of this Agreement shall be interpreted in such a manner as to be effective and valid under applicable law, but if any provision of this Agreement shall be determined to be invalid by a final judgment or decree of a court of competent jurisdiction, such provision shall be ineffective only to the extent of such prohibition or invalidity, without invalidating the remainder of that provision, or the remaining provisions of this Agreement unless the invalid provision is so material that its invalidity deprives either Party of the basic benefit of their bargain or renders this Agreement meaningless.

22. **Corporate Authority.** Each of the undersigned represents and warrants that (i) the Party for which he/she is executing this Agreement is duly authorized and existing, (ii) he/she is duly authorized to execute and deliver this Agreement on behalf of the Party for which he/she is signing, (iii) by so executing this Agreement, the Party for which he/she is signing is formally bound to the provisions of this Agreement, and (iv) the entering into this Agreement does not violate any provision of any other Agreement to which the Party for which he/she is signing is bound.

23. Counterparts; Facsimile Signatures. This Agreement may be executed in counterparts, all of which shall constitute the same Agreement, notwithstanding that all parties to this Agreement are not signatory to the same counterpart. Signature and acknowledgement pages may be detached from the counterparts and attached to a single copy of this Agreement to physically form one (1) original document. These counterparts may be transmitted by facsimile or Portable Document Format (PDF), with the originals to be thereafter provided by the Parties. Such facsimiles or electronic copies shall be deemed original signatures.

IN WITNESS THEREOF, these parties have executed this Agreement as of the date first written above.

“DISTRICT”

“CONTRACTOR”

MIDWAY CITY SANITARY DISTRICT,
a public entity

AKM CONSULTING ENGINEERS, a
California corporation

By: _____
Robert Housley
General Manager

By: _____

Name: _____

Title: _____

APPROVED AS TO FORM:

By: _____

Name: _____

Title: _____

General Counsel
Midway City Sanitary District

Tax ID No. _____

If CONTRACTOR is a corporation, a Corporate Resolution and/or Corporate Seal is required. If a partnership, Statement of Partnership must be submitted to District.

**EXHIBIT "A" TO AGREEMENT
CONTRACTOR'S PROPOSAL**

Midway City Sanitary District

Proposal for Manholes at Westminster Boulevard and Springdale Street Siphon



Submitted by:

AKM Consulting Engineers

553 Wald

Irvine, CA 92618



949-753-7333

May 10, 2024



May 10, 2024

Midway City Sanitary District

14451 Cedarwood Avenue
Westminster, CA 92683

Attention: Mr. Robert Housley, General Manager

Subject: Proposal for Preparation of Plans and Specifications for Construction of Manholes Upstream and Downstream of the Inverted Siphon at Westminster Boulevard and Springdale Street

Dear Mr. Housley:

In response to your request, AKM Consulting Engineers (AKM) is pleased to submit this proposal to prepare plans and specifications for the construction of manholes upstream and downstream of an existing 8-inch diameter inverted sewer siphon, located at the intersection of Westminster Boulevard and Springdale Street.

Background

The Midway City Sanitary District (MCSD) owns an 8-inch diameter vitrified clay pipe (VCP) sewer in Springdale Street, north of Westminster Boulevard, the most southerly reach of which extends from Manhole MH15030 and terminates at a manhole at the intersection of Westminster Boulevard and Springdale Street (MH15032). Until 1970, this sewer existed with a constant slope from Manhole MH15030 to Manhole MH15032. In 1970, the Orange County Sanitation District (OCSD) constructed the 60-inch diameter reinforced concrete Westminster Avenue Interceptor Sewer, which is located approximately 43 feet north of Manhole MH15032 at its crossing of MCSD's 8-inch sewer. The OCSD's "As Constructed" plan for the Westminster Avenue Interceptor Sewer shows a 48-inch diameter manhole approximately 8 feet north of the centerline of their interceptor sewer and an inverted siphon with a length of 15 feet. Review of a CCTV recording (from 2014) of the 8-inch MCSD sewer shows a vertical drop of approximately 2 feet. A CCTV recording of the section to the south of the interceptor sewer is not available, but it is reasonable to assume that a similar drop exists there as well. Design of this inverted siphon does not meet any industry standard. There are no upstream and downstream manholes on either side of the siphon, the pipe does not descend and ascend with mild slopes, nor is there an air jumper, which are all essential elements for maintaining the siphon.

In March 2024, Empire Pipe Cleaning and Equipment, Inc. (Empire) was cleaning the section of the sewer from Manhole MH15023 northerly using a 6-inch skid nozzle, not being aware of the existence of the siphon. The nozzle dropped into the siphon. Empire retrieved the hose and the nozzle, and observed gravel, fines material, and broken pipe. Empire then used a 0.5" nozzle without a skid, in an attempt to clear the material. However, the smaller nozzle got stuck in the pipe approximately 40 feet north of Manhole MH15032, which is very close to the interceptor sewer. Empire could not retrieve the nozzle, and cut the attached hose at Manhole 15032. It is assumed that the nozzle got stuck at the 90 degree bend at the bottom of the siphon. It is evident that the hose and the nozzle are plugging the pipes, which results in the sewage backing up in the upstream (northerly) sewer up to Manhole MH14028 at the intersection of Navajo Street and Sioux Road. The flow is now being conveyed westerly and northerly in Meinhardt Road to a crossing of the 405 Freeway between Allison Circle and White Circle, then in Hammon Place to the Hammon Lift Station. MCSD believes there is now something wrong with the siphon and it may even be partially collapsed.



Eventually, a new siphon parallel to the existing one will need to be constructed. However, that process will take additional time to design, get permitted, bid, and constructed. It is proposed that MCSD construct manholes upstream and downstream of the existing siphon and attempt to remove the nozzle and hose stuck in it, establishing the conditions prior to March 2024.

Scope of Work

We propose to implement the following scope of work:

1. Conduct field surveying to determine the invert elevations of various sewers at nine (9) manholes (*MCSD to coordinate with OCSD for access to their manholes*).
2. Obtain as-built plans of the utilities at the Westminster Boulevard and Springdale Street intersection and in Springdale Street north of the intersection.
3. Conduct field review of the project site and compare the as-built utility information to the USA marked utilities in the area (*MCSD to call USA to mark area*).
4. Select locations of the upstream (north) and downstream (south) manholes. We anticipate locating the upstream manhole north of the crosswalk in Springdale Street.
5. Prepare plans, profiles and details, as well as specifications for the project, including front end documents utilizing MCSD standards, including front end documents utilizing MCSD standards, and technical specification.

Conduct geotechnical investigation with one boring to develop recommendations for shoring and dewatering for the manhole, as well as future parallel inverted siphon design. Our proposal includes \$2,500 for permit fees required for the geotechnical field work.

6. Contact the City of Westminster and OCSD, identify permit requirements.
7. Submit the plans and specifications to MCSD, OCSD and the City of Westminster for review and comments.
8. Address the comments, revise the plans and specifications, and submit for final approval.
9. Prepare the final bid-ready contract documents.
10. Provide bidding support services.
11. Provide engineering services during construction, including as-built plans.

We have assumed that the specifications will require the construction traffic control plans to be prepared by the selected contractor, reflecting its means and methods for the construction.

Schedule

We anticipate completing tasks 1 through 8 within 6 weeks of obtaining all as-built information, subject to being able to meet with the City of Westminster and OCSD, and completion of the geotechnical investigation. Task 8 will be completed with 2 weeks of obtaining comments, and Task 10 will be completed within 1 week following receipt of comments.

Budget

We propose to complete the above scope of work on a time and materials basis with an estimated total cost of \$119,164 as detailed in Table 1. AKM's current rate schedule is provided in Table 2.



The inspection hours are estimated at 80 hours, but will be charged on a time and materials basis at rate of \$197/hour thereafter.

The proposal does not include payments for any types of easements, inspection fees, etc. that may be required by the City of Westminster and/or other agencies. It will be the responsibility of MCSD to cover the costs for these types of fees.

Project Team

AKM's Project Team will include:

- Mr. Zeki Kayiran, PE, who will serve as the Principal in Charge and be the responsible contract representative to Midway City Sanitary District
- Mr. Morgan Ying, PE, as the Project Engineer, who has provided similar services to public agencies for over 40 years
- Ms. Diann Pay, PE, will serve as Principal Engineer and assist with coordination of project tasks.
- Mr. Adrian Hernandez will serve as Associate Engineer on the project.
- Mr. Emin Kayiran will serve as Senior Construction Manager.
- The Field Engineer/Inspector will be dependent on the schedule of the construction work and the availability of AKM's inspector

We appreciate the opportunity to submit this proposal and look forward to working with you on this important project. Should you have any questions or require additional information, please do not hesitate in contacting the undersigned.

Sincerely,

AKM Consulting Engineers

Diann Pay, P.E.

Principal

**Table 1
Staff Hour and Fee Estimate**

	Description	Principal in Charge	Principal Engineer	Project Engineer	Associate Engineer	Senior Construction Manager	Senior Field Engineer / Inspector	CADD	Office Support	Total Hours	Sub-Consultant	Cost
1	Conduct field surveying		4	4						8	\$2,200	\$4,148
2	Obtain and review the as-built plans		4	8	8					20		\$4,220
3	Conduct field review			4	8					12		\$2,272
4	Select locations of manholes	4		4				4		12		\$2,416
5	Prepare plans, profiles and details, as well as specifications. Conduct geotechnical investigation with one boring and \$2,500 for permit fees.	12		40	48			60	8	168	\$29,000	\$57,104
6	Contact the City of Westminster and OCSD, identify permit requirements		4	8						12		\$2,884
7	Submit the plans and specifications to MCSD, OCSD and the City of Westminster for review and comments			2					4	6		\$804
8	Address the comments revise the plans and specifications, submit for final approval	4		16	20			12	4	56		\$9,836
9	Prepare the final bid-ready contract documents	4		4	4			8	4	24		\$3,888
10	Provide bidding support services	12		8					2	22		\$5,076
11	Provide engineering services during construction, as-built plans	4		16		16	80	8	4	128		\$25,516
12	Expenses											\$1,000
	<i>Total Hours</i>	40	12	114	88	16	80	92	26	468		
	<i>Rate (\$/Hr)</i>	\$253	\$253	\$234	\$167	\$233	\$197	\$117	\$84			
	Total Cost	\$10,120	\$3,036	\$26,676	\$14,696	\$3,728	\$15,760	\$10,764	\$2,184		\$31,200	\$119,164

TABLE 2
AKM Consulting Engineers
Rate Schedule 2024

Labor Classification	Hourly Rate 2024
Principal	\$253
Principal Engineer	\$253
Project Manager	\$246
Project Engineer	\$234
Senior Construction Manager	\$233
Construction Manager	\$200
QA/QC Manager	\$233
Senior Engineer	\$215
Senior Field Engineer / Inspector	\$197
Field Engineer / Inspector	\$173
Associate Engineer	\$167
Staff Engineer	\$148
Financial Analyst	\$136
Senior Designer / Senior CADD Technician	\$117
Designer / CADD Technician	\$109
Assistant Engineer	\$107
Engineering Technician	\$99
Engineering Aide	\$84
Office Support	\$84
Data or Word Processing	\$81

Out of pocket expenses (blueprinting, reproduction and printing, delivery, etc.) will be invoiced at cost plus 10%. Subcontracted services will be marked up 10% in order to cover costs associated with administration, coordination and management of subcontractors. Mileage will be invoiced at \$0.65/mile. This schedule of rates is in effect until December 31, 2024, at which time it may be adjusted.

AGENDA ITEM #8D

Date: May 21, 2024

To: Board of Directors

From: Robert Housley, General Manager

Prepared by: Cynthia Olsder, Board Clerk

Subject: Discussion of Election Information for the November 5, 2024 General Election and Transmittal of Election Information Special District

BACKGROUND

The District received a Transmittal of Election Information request to submit the Transmittal of Election Information form **by May 31, 2024**, and the District Map showing the current district boundary lines, with divisions (if any), regardless if changes have occurred, **by July 3, 2024**, to the Registrar of Voters office.

The names of the Directors whose terms will expire and whose seats will be scheduled for election on November 5, 2024 must be listed.

DISCUSSION

Information on whether the District is authorizing 200 or 400 words to be used in a Candidate's Statement of Qualifications is also required.

Candidate Filing for the November 5, 2024, General Election will be July 15, 2024 through August 9, 2024, 5 P.M., and the Candidates Handbook will be on the Registrar of Voters website before the filing period begins.

STAFF RECOMMENDATION

Staff recommends that the Board review, discuss and provide direction to Staff.

FISCAL IMPACT

None.

ATTACHMENTS:

1. Memo from County of Orange, Registrar of Voters

Cynthia Olsder

Subject: FW: 2024 Presidential General Election Information Request

From: Mailhot, Julianna <Julianna.Mailhot@ocvote.gov>
Sent: Thursday, May 16, 2024 10:58 AM
To: Cynthia Olsder <colsder@midwaycitysanitaryca.gov>
Subject: 2024 Presidential General Election Information Request

Good afternoon, Superintendent/Chancellor,

The Registrar of Voters has implemented a new way to submit your Transmittal of Election Information form and District Map through an online Election Jurisdiction Verification portal. The portal will allow you to complete, sign and upload your district information, in one convenient place.

On the Transmittal of Election Information page, **please list the names of Governing Board Members** whose terms will expire and whose seats will be scheduled for election on November 5, 2024. This would include any Governing Board Members appointed since your last election. Appointed Governing Board Members must file for the two-year unexpired term if they were appointed to fill a vacancy which would not have been scheduled for election until 2026.

We also need to know if your **District is authorizing 200 or 400 words** to be used in a Candidate's Statement of Qualifications.

Please upload the completed Transmittal of Election Information form by **May 31, 2024**.

On the District Map page, you will print, sign, and upload you district map and verification form.

Pursuant to Elections Code § 10522, the district is required to submit a map showing the current district boundary lines, with divisions (if any), regardless if changes have occurred, by **July 3, 2024**.

To get started, please click on the invitation link:

<https://ocvote.gov/apps/ejv/register/?invitationCode=eyJmdWxsLW5hbWUiOiJSb2JlcnQgSG91c2xleSIsInJlZ2lzdGVyLWVtYWIsIjoiY29sc2RlckBtaWR3YXljaXR5c2FuaXRhcnljYS5nb3YiLCJkaXN0cmliZC10eXBlljoiU3BIY2lhbCIsImRpc3RyaWN0IjoiTWlkd2F5IENpdHkgU2FuaXRhcnkgRGlzdHJpY3QifQ>

Note: The above invitation link is unique, and you should not forward it to anyone else. If you would like others to complete the documents on your behalf, please email their individual name and email address to Julianna.Mailhot@ocvote.gov, and a new invitation link will be sent.

Candidate Filing for the November 5, 2024 Presidential General Election will be July 15, 2024 through August 9, 2024, 5:00 p.m. The Candidate's Handbook will be on our website before the filing period begins. We ask that you post this information to advise your members of these important dates.

Thank You.

Julianna Mailhot | Candidate and Voter Services Lead | Orange County Registrar of Voters
1300 S. Grand Avenue, Bldg C | Santa Ana, California 92705 | 714.567.7563
julianna.mailhot@ocvote.gov



May 3, 2024

Mr. Mark Nguyen
Board President
Midway City Sanitary District
14451 Cedarwood Avenue
Westminster, CA 92683

Dear Mr. Nguyen:

On behalf of the Board of Directors of Special District Risk Management Authority (SDRMA) and our members I want to personally thank the Midway City Sanitary District for nominating Robert Housley as a candidate for SDRMA's Board of Directors. I am pleased to advise you that Mr. Housley has been appointed to serve on SDRMA's Board of Directors to fill the remaining term which expires December 31, 2025.

Robert will join SDRMA's other six (6) directors listed below:

1. Sandy Seifert-Raffelson, Herlong Public Utility District
2. Bob Swan, Groveland Community Services District
3. Jesse Claypool, Honey Lake Valley Resource Conservation District
4. Mike Scheafer, Costa Mesa Sanitary District
5. Tim Unruh, Kern Mosquito and Vector Control District
6. Tom Wright, Clovis Veterans Memorial District

The newly appointed director will be seated at the August 7-8, 2024 board meeting.

Again, we thank the Midway City Sanitary District for its participation and commitment to SDRMA.

Sincerely,
Special District Risk Management Authority

Sandy Seifert-Raffelson
President
Board of Directors



Maximizing Protection. Minimizing Risk.

Cynthia Olsder

Subject: FW: Final OC LAFCO FY 2024-25 Budget
Attachments: FY 2024-25 Final Budget Special District.pdf

From: Luis Tapia <ltapia@oclafco.org>
Sent: Thursday, May 9, 2024 11:28 AM
Subject: Final OC LAFCO FY 2024-25 Budget

General Manager,

The OC LAFCO FY 2024-25 final budget approved by the Commission on May 8, 2024, is attached for your reference. Also attached is a list containing the cities' apportionments prepared by the County Auditor-Controller's office, which will issue an invoice for payment of your apportionment by July 1.

You may contact me by phone or email at the contact information given below if you have any questions.

Thank you
Luis Tapia
Assistant Executive Officer
ltapia@oclafco.org
(714) 640-5100 -Office



Our offices are closed every other Friday. You may access the agency's annual calendar for office closures and other key events at www.oclafco.org.



Orange County Local Agency Formation Commission
Fiscal Year 2024-25 Budget
 (Approved May 8, 2024)

		FY 24/25 Approved Budget
<i>Apportionment Increase Factor (%)</i>		<i>12.0%</i>
1	Revenue & Cash Reserves Use / (Addition)	
2	Cash Reserves Use / (Addition)	\$ 240,340
3	4000 LAFCO Apportionment	1,581,320
4	4200 Interest	38,390
5	Total Revenue & Cash Reserves Use / (Addition)	1,860,050
6	Expense	
7	Salaries & Benefits	
8	5000 Salaries	657,300
9	5010 Hourly Employees	20,800
10	5106 Retirement	265,900
11	5109 Retiree Health Benefits	22,000
12	5108 Health Insurance	88,900
13	5110 Dental Insurance	11,600
14	5112 Life Insurance	420
15	5118 Unemployment Insurance	200
16	5119 Health Reimbursement Arrangement	7,800
17	5102 Optional Benefit Plan	18,500
18	5104 Deferred Compensation	19,000
19	5116 Medicare	10,200
20	5114 Worker's Compensation	-
21	5120 Salary Continuance	1,650
22	5122 Accidental Death Insurance	120
23	5125 Executive Car Allowance	7,200
24	Salaries & Benefits Total	1,131,590
25	Operations, Prof. Services & Other	
26	Office Operations	
27	5150 Information Technology	21,600
28	5151 Internet & Electronic Services	20,500
29	5200 County Charges	12,000
30	5250 Insurance	15,760
31	5350 Membership/Subscriptions	40,400
32	5450 Office Equipment/Supplies	26,100
33	Professional Services	
34	5510 Legal	60,000
35	5520 Audit/Accounting	57,000
36	5530 Human Resources	35,000
37	5540 Other Professional	200,000
38	Other Expense	
39	5535 Mapping	4,000
40	5550 Investment Admin Fees	850
41	5600 Public Noticing / Communications	12,000
42	5610 Unincorporated Areas Program	11,000
43	5650 Rents/Improvements/Maintenance	115,000
44	5675 Equipment Leases & Maintenance	8,100
45	5700 Commissioner/Staff Expenses	5,000
46	5710 Commission Stipends & Taxes/Fees	16,450
47	5750 Professional Development	20,000
48	5800 Registration/Travel	35,300
49	5850 Commission Meeting Expenses	12,400
50	Operations, Prof. Services & Other Total	728,460
51	Total Expense	1,860,050
52	Net Budget	\$ -



Orange County Local Agency Formation Commission
Fiscal Year 2024-25 Budget
 (Approved May 8, 2024)

	FY 24/25 Approved Budget
Projected Cash Reserves	
Reserved Cash	
Contingency Reserve	\$ 100,000
Litigation Reserve	75,000
Unfunded Liability Reserve	30,000
Operating Reserve (25% Budgeted Expenses)	465,013
Total Reserved Cash	670,013
Unreserved Cash	
Balance at the Beginning of FY	514,377
Addition / (Drawdown) to Unreserved Cash	(240,340)
Total Unreserved Cash	274,037
Total Projected Cash Reserves	\$ 944,049

REVENUES

The following summarizes the revenue categories of the OC LAFCO Budget:

4000 OC LAFCO Apportionment

These funds are provided by the County, independent special districts and cities. The County pays 1/3 of the total apportionment cost. The cost allocation formulas for the cities and special districts are in accordance with the alternative formulas adopted by the City Selection Committee and the Independent Special Districts Selection Committee respectively.

4050 Filing Fees

These funds are provided by incoming project applications, including but not limited to annexations, reorganizations, incorporations, dissolutions, and consolidations. Filing fees vary with each project received and are not budgeted as revenue due to the uncertainty of when applications will be filed. Filing fees are collected to offset OC LAFCO salaries, benefits and other expenditures associated with applications.

4150 Miscellaneous Revenue

These funds are incurred by nonoperational income including but not limited to reimbursements.

4200 Interest

These funds are the interest earned from the agency's bank and County payroll accounts and investment portfolio, including the Local Agency Investment Fund (LAIF) and Orange County Fund (OC Fund).

EXPENDITURES

The following summarizes the expenditure categories of the OC LAFCO Budget:

5000-5125 Salaries and Benefits

These categories include costs incurred for OC LAFCO employee salaries and benefits, including retirement, life, accidental and disability insurance, health and dental insurance, and Medicare. OC LAFCO contracts with the County of Orange for payroll and benefit services.

5150 Information Technology

This category includes costs incurred for the technical support for regular maintenance and upgrades to the OC LAFCO computer systems and website. OC LAFCO contracts with independent consultants for IT and website services.

5151 Internet and Electronic Services

This category includes costs for the usage, technical support, equipment, leasing and maintenance of business electronic devices and internet services.

5200 County Charges

This category includes costs incurred for payroll processing, records archiving and storage, and billing, collection and intranet services provided by the County of Orange.

5250 Insurance

This category includes costs incurred for insurance coverage. OC LAFCO contracts with the County and a joint powers authority for the following coverages for instances that occur during the general operation of the agency.

- General Liability– Includes coverage for personal injury (including bodily injury and property damage), non-owned auto liability, public officials’ errors and omissions and employment practices liability.
- Crime – Includes coverage for employee or non-employee theft, burglary, forgery or alteration, computer fraud, funds transfer fraud.
- Property - Includes per occurrence, all perils coverage for damage to property including personal property and business interruption coverage.
- Workers’ Compensation – Includes coverage for employees involving work-related injuries.

5350 Membership/Subscriptions

This category includes memberships and subscriptions fees to CALAFCO, CSDA, OCBC, CDR and other applicable memberships.

5450 Office Equipment and Supplies

This category includes costs incurred for the purchase of office supplies and equipment, computers, and software that support agency operations.

5500 Professional Services

This category includes costs incurred for professional services provided to OC LAFCO. The following are subcategories for professional services:

- ✓ **5510 Legal** – OC LAFCO general counsel services.
- ✓ **5520 Auditing/Accounting** – Bookkeeping, accounting and auditing services. OC LAFCO audited financial statements are prepared by an independent auditor.
- ✓ **5530 Human Resources** – Personnel services that may be provided by an independent consultant for assistance with recruitment, employment labor, professional development and other human resource areas.
- ✓ **5535 Mapping** – OC LAFCO’s Geographic Information System (GIS) and other mapping programs.

- ✓ **5540 Other Professional Services** – Consulting and professional services for meeting facilitation, peer reviews, and preparation of Municipal Service Reviews, fiscal studies and other studies, reports and projects.

5550 Investment Admin Fees

This category includes costs incurred for administrative fees charged by the County of Orange for financial services related to the investment and payroll accounts.

5600 Public Noticing/Communications

This category includes costs incurred for required legal notices and other communications for Commission-initiated and other projects (e.g., spheres of influence reviews and updates, municipal service reviews, and annual budget adoption) that are not reimbursable through application fees.

5610 Unincorporated Areas Program

This category includes costs incurred for the processing of applications under the Commission’s Unincorporated Areas Program.

5650 Rents/Improvements/Maintenance

This category includes costs for leasing, improvements, and maintenance of OC LAFCO office space.

5675 Equipment Leases/Maintenance

This category includes costs for leasing and maintenance of the OC LAFCO copier and printers.

5700 Commissioner/Staff Expenses

This category includes miscellaneous business expenses incurred by Commissioners and staff.

5710 Commissioner Stipends & Taxes/Fees

This category includes Commissioner meeting stipends and related employment taxes and fees.

5750 Professional Development

This category includes costs related to employee professional development (e.g., college/university degree programs and courses, certificate programs, leadership seminars).

5800 Transportation/Travel/Registration

This category includes costs incurred for registration, transportation, and travel expenses for commissioners and staff to attend CALAFCO conference, workshop, and board meetings and other business-related meetings and activities.

5850 Commission Meeting Expenses

This category includes costs incurred for communications, room rental, parking and miscellaneous expenses for Commission meetings.

RESERVES

Contingency Reserve

Restricted funds used to cover any unforeseen future agency loss and/or urgency (i.e., property or equipment damage, loss or theft).

Reserve for Litigation

Restricted funds used for costs related to agency litigation not covered by application fees and deposits.

Unfunded Liability Reserve

Restricted funds used to offset anticipated agency liabilities (i.e., employee compensated absences).

OC LAFCO FY 2024-25 Special District Allocations

District	ISDOC Formula Calculation FY 2024-25
Silverado-Modjeska Rec. & Park	\$ 632.53
Surfside Colony Stormwater	632.53
Surfside Colony CSD	632.53
Rossmoor/Los Alamitos Area Sewer District	3,057.22
Capistrano Bay CSD	3,057.22
Rossmoor CSD	3,057.22
Three Arch Bay CSD	3,057.22
Emerald Bay CSD	3,057.22
Buena Park Library District	3,057.22
Placentia Library District	3,057.22
Orange County Cemetery District	4,585.83
Orange County Vector Control District	6,114.44
Total Non-Enterprise Districts	\$ 33,998.40
Sunset Beach Sanitary District	6,114.44
Serrano Water District	18,290.60
East Orange Co. Water District	24,352.33
Midway City Sanitary District	24,352.33
Trabuco Canyon Water District	24,352.33
Costa Mesa Sanitary District	24,352.33
El Toro Water District	30,466.77
Mesa Water District	30,466.77
Yorba Linda Water District	36,528.49
South Coast Water District	36,528.49
Moulton Niguel Water District	42,642.93
Santa Margarita Water District	42,642.93
Municipal Water District of O.C.	48,651.94
Orange County Water District	48,651.94
Irvine Ranch Water District	54,713.65
Total Enterprise Districts	\$ 493,108.27
Total Special Districts	\$ 527,106.67



April 17, 2024

The Honorable Laphonza Butler
United States Senate
112 Hart Senate Office Bldg.
Washington, D.C. 20510

The Honorable Alex Padilla
United States Senate
331 Hart Senate Office Bldg.
Washington, D.C. 20510

The Honorable Jim Costa
United States House of Representatives
2081 Rayburn House Office Building
Washington, DC 20515

Dear Senator Butler, Senator Padilla, and Representative Costa,

The California Governor's Office of Emergency Services (Cal OES) is the state administering agency for Pre-Disaster Mitigation (PDM) funding and is in receipt of a request from the Midway City Sanitary District as part of the Fiscal Year 2025 Congressionally Directed Spending process. The Midway City Sanitary District requests \$1,500,000 to install a microgrid for their headquarters. The installation of the microgrid would ensure continuity of operations during prolonged outages and help the district move towards more resilient infrastructure and environmentally friendly operations.

Cal OES believes this project will greatly benefit the local community and the resilience of the State. Typically, PDM grant projects are ranked and rated by Cal OES and submitted to the Federal Emergency Management Agency (FEMA) for final award decisions. Due to the nature of this unique funding opportunity, Cal OES program experts have conducted a preliminary review of this project and have determined that it meets the federal program qualifications. If selected for funding, Cal OES' administration of this project will follow the same strict requirements, qualifications, and scrutiny as the traditional project selection and monitoring process.

An award for this project signifies an investment not only by the Midway City Sanitary District and the state, but also by Congress. As Community Project Funding is determined legislatively, Cal OES encourages members representing the respective districts to closely follow projects that are implemented to meet congressional intent appropriately and ensure compliance with FEMA guidelines. Additionally, Cal OES requests that Congress include funding in the Fiscal Year 2025 appropriation legislation to cover state management and administration costs for all Congressionally Directed Spending.

Sincerely,

Nancy Ward
Director



3650 SCHRIEVER AVENUE, MATHER, CA 95655
(916) 845-8506 TELEPHONE (916) 845-8511 FAX

www.CalOES.ca.gov



**California Special
Districts Association**

Districts Stronger Together

May 14, 2024

The Honorable Members of the California State Legislature
State Capitol
Sacramento, CA 95814

RE: 2024 Climate Resilience Bond Priorities

Climate Resilience Bond: California Air Resource Board: Advanced Clean Fleets (Zero Emission Vehicles) Local Agency Funding.

Dear Senators and Assembly Members,

The California Special Districts Association (CSDA), representing over 1,000 independent special districts throughout the state, respectfully requests the inclusion of funding for infrastructure and vehicles to comply with the California Air Resource Board (CARB) Advanced Clean Fleets (ACF) Zero Emission Vehicles (ZEV) mandates. Additionally, CSDA seeks parity with other local governments in funding for like services and supports the water-related asks of our local water agency partners. CSDA represents all types of special districts, which provide millions of Californians with essential local services such as fire protection, water, healthcare, recreation and parks, and more.

California Air Resource Board: Advanced Clean Fleets / Zero Emission Vehicles Local Agency Funding

CSDA is seeking funding for compliance with ACF / ZEV particularly, and parity with other local governments for eligibility for any funding of like services.

CSDA respectfully requests any climate-related bond measure to:

- Allocate up to \$500 million for local government (Special Districts, Cities and Counties) for compliance with the ACF mandate for zero emission vehicles and the infrastructure to acquire and service them.
- Support the water infrastructure goals as outlined by local water agencies.
- General parity and equal access to funding among local governments for like services.

Local government vehicle fleets are required to show that 50 percent of medium-duty and heavy-duty vehicle purchases are zero-emission beginning in 2024 and 100 percent of vehicle purchases are zero-emission by 2027. Small government fleets, defined as those with 10 or fewer vehicles and those in designated counties, may start their ZEV purchases beginning in 2027. Alternately, local government fleet owners may elect to use the ZEV Milestones Option, which allows for a graduated percentage of fleets to be in compliance by certain dates, depending on vehicle type. Local government fleets may purchase either ZEVs or near-ZEVs, or a combination of ZEVs and near-ZEVs, until 2035. Starting in 2035, only ZEVs will be compliant. *These new vehicles, which our communities will depend on for essential services, will be inoperable absent the prior design, construction, and energization of specific infrastructure to service and fuel or re-charge. The ACF mandate did not come with new funding.*



**California Special
Districts Association**

Districts Stronger Together

Parity in Funding For like Services and Infrastructure

Special Districts provide many of the same essential services that our partners in other local government types do, including building and maintaining crucial infrastructure, delivery of the services that sustain life and communities, responding to extreme weather events, disasters and wildfires, and providing for quality of life. Nearly all of California's 39 million residents receive at least one essential service from a special district, and those communities that rely on special districts are left out when special districts are not included.

Funding should reflect this reality for like services, infrastructure, and work. Should you have any inquiries, please do not hesitate to contact me at anthonyt@cda.net.

Sincerely,

A handwritten signature in black ink, reading 'Anthony Tannehill', written in a cursive style.

Anthony Tannehill
Legislative Representative



California Special Districts Association
Districts Stronger Together

[CONTACT US](#) [JOIN](#) [SUPPORT](#)



[LOGIN](#)

Blog Viewer

CSDA Requests State Support for Unfunded CARB ZEV Mandate



By Vanessa Gonzales posted 5 hours ago

1 LIKE



By: @Anthony Tannehill

To aid special districts with compliance, and in coordination with our local government partners, CSDA is requesting inclusion of up to \$500 million (see [here](#) and [here](#)) in any statewide Climate Resiliency Bond to help local agencies fund the infrastructure and acquire the vehicles to comply the California Air Resources Board (CARB) Advanced Clean Fleets (ACF) regulation / Zero Emission Vehicles (ZEV) mandates. Additionally, CSDA seeks parity with other local governments in bond funding for like services.

Current Climate Resiliency Bond proposals that may be put before the voters this year pending passage by the Legislature include Senate Bill 638 (Eggman), Assembly Bill 1567 (Garcia) and SB 867 (Allen).

Contact us



Per the ACF regulation approved last year ([see CSDA's new laws series](#)), local government vehicle fleets are required to show that 50 percent of medium-duty and heavy-duty vehicle purchases are zero-emission beginning in 2024 and 100 percent of purchases are zero-emission by 2027. Small government fleets, defined as those with 10 or fewer vehicles and those in designated counties, may start their ZEV purchases beginning in 2027. Alternately, local government fleet owners may elect to use the ZEV Milestones Option, which allows for a graduated percentage of fleets to be in compliance by certain dates, depending on vehicle type.

Local government fleets may purchase either ZEVs or near-ZEVs, or a combination of ZEVs and near-ZEVs, until 2035. Starting in 2035, only ZEVs will be compliant.

Unfortunately, The ACF mandate did not come with new funding mechanisms for either the infrastructure critical to operating these new vehicles or the vehicles themselves.

Local agency fleet managers report challenges in compliance with the mandate that include a lack of vehicles that meet the needs of their district, a lack of infrastructure to service and operate such vehicles, concerns about electrical power reliability, and start-up costs.

Nearly all of California's 39 million residents receive at least one essential service from a special district, and those communities that rely on special districts are left out when special districts are not included in funding opportunities. Funding should reflect this reality for like services, infrastructure, and work.

Inquiries or comments related to this funding request should be directed to CSDA Legislative Representative Anthony Tannehill at anthonyt@csgda.net.

#AdvocacyNews

#FeatureNews

#EnvironmentandDisasterPreparedness

#ClimateAdaptation

0 comments

8 views

Permalink

<https://www.csgda.net/blogs/vanessa-gonzales/2024/05/14/csgda-requests-state-support-for-unfunded-carb-zev>



FIND IT FAST

- SDLF Scholarships
- Register for an Event
- Career Center
- Membership

CALIFORNIA SPECIAL DISTRICTS ALLIANCE

April 9, 2024

Honorable Members of the California Congressional Delegation
U.S. House of Representatives
Washington, D.C. 20515

RE: Support Request – H.R. 7525 Special District Grant Accessibility Act

Dear Representatives:

On behalf of California's more than 2,000 special districts, we respectfully request that you support the Special District Grant Accessibility Act (H.R. 7525). This important bipartisan legislation was overwhelmingly approved by the House Oversight and Accountability Committee on March 7, 2024, and is now awaiting action by the full House. We urge you to work with congressional leadership to ensure that the legislation is considered in a timely fashion.

H.R. 7525 would require the Office of Management and Budget (OMB) to issue guidance to federal agencies requiring special districts to be recognized as local governments for the purpose of federal financial assistance determinations. The bill also would codify in federal law a long-overdue, formal definition of "special district."

Special districts are local governments created by the people of a community to deliver specialized services essential to their health, safety, economy, and well-being. For millions of Californians, special districts provide a broad range of essential services and infrastructure including water, flood protection, sanitation, fire protection, parks and open space, healthcare, mosquito abatement, ports and harbors, airports, cemeteries, resource conservation, libraries, electricity, and more.

Despite the significance of special districts throughout the United States, federal law lacks a consistent definition of these special purpose units of local government. As a result, some communities served by special districts face challenges in accessing federal funding opportunities as their local service providers are commonly omitted from the definition of eligible units of local government in legislative proposals that authorize federal programs and funding. Moreover, special districts lack official population figures and are therefore not recognized by the U.S. Census Bureau as "geographic units of government." As a result, special districts are unable to gain access to certain formula-driven grants and resources.

Again, we urge you to support the Special District Grant Accessibility Act and to work with your House colleagues to prioritize passage of this critically important bill. Thank you for considering this request.

Collectively,

A coalition of local government, business, non-profit, and other stakeholders listed as follows:

Statewide Local Government Associations

1. California Special Districts Association
2. California Association of Local Agency Formation Commissions
3. California Association of Public Cemeteries
4. California Association of Recreation and Park Districts
5. California Municipal Utilities Association
6. California Rural Water Association
7. Fire Districts Association of California
8. Mosquito and Vector Control Association of California

Special Districts

9. Alameda County Mosquito Abatement District
10. Alameda County Water District
11. Alamo-Lafayette Cemetery District
12. Altadena Library District
13. Antelope Valley Mosquito and Vector Control District
14. Aromas Water District
15. Auburn Area Recreation and Park District
16. Bardsdale Cemetery District
17. Beach Cities Health District
18. Bear Valley Water District
19. Beckwourth Peak Fire Protection District
20. Biola Community Services
21. Butte Valley Protection District
22. Byron-Brentwood-Knightesen Union Cemetery District
23. Calaveras County Water District
24. Cambria Community Services District
25. Cameron Estates Community Services District
26. Camrosa Water District
27. Chico Area Recreation & Park District
28. Chino Valley Independent Fire District
29. Chowchilla Cemetery District
30. Coalinga-Huron Recreation and Park District
31. Cobb Area County Water District
32. Consolidated Mosquito Abatement District
33. Contra Costa Mosquito and Vector Control District
34. Cordova Recreation and Park District
35. Corning Cemetery District
36. Corning Healthcare District
37. Cortina Community Services District
38. Costa Mesa Sanitary District

39. Davis Cemetery District
40. Delano Mosquito Abatement District
41. Delhi County Water District
42. Delta Mosquito and Vector Control District
43. Desert Healthcare District
44. Diablo Water District
45. Donner Summit Public Utility District
46. Dublin San Ramon Services District
47. Dunnigan Fire Protection District
48. East Side Mosquito Abatement District
49. El Dorado County Fire Protection District
50. Elsinore Valley Cemetery District
51. Fair Oaks Cemetery District
52. Fallbrook Regional Health District
53. Foothill Municipal Water District
54. Fulton-El Camino Recreation and Park District
55. Galt Arno Cemetery District
56. Garden Valley Fire Protection District
57. Georgetown Divide Public Utility District
58. Gold Mountain Community Services District
59. Gold Ridge Resource Conservation District
60. Golden Valley Municipal Water District
61. Goleta Sanitary District
62. Grossmont Healthcare District
63. Groveland Community Services District
64. Gualala Community Services District
65. Hayward Area Recreation and Park District
66. Healthy Petaluma District
67. Heritage Ranch Community Services District
68. Hidden Valley Lake Community Services District
69. Hi-Desert Water District
70. Hilmar Cemetery District
71. Hilmar County Water District
72. Hopland Cemetery Special District
73. Hopland Fire Protection District
74. Hornbrook Community Services District
75. Humboldt Bay Municipal Water District
76. IHSS Public Authority of Marin
77. Indian Valley Community Services District
78. Inverness Public Utility District
79. Jamestown Sanitary District
80. Kern County Cemetery District #1
81. Kern County Pest Control District

82. Kern Mosquito and Vector Control District
83. Kern River Valley Cemetery District
84. Lake County Vector Control District
85. Lake Cuyamaca Recreation and Park District
86. Lake Valley Fire Protection District
87. Leavitt Lake Community Services District
88. Live Oak Cemetery District
89. Los Osos Community Services District
90. Madera/Chowchilla Resource Conservation District
91. Mammoth Community Water District
92. Marin City Community Services District
93. Mesa Water District
94. Midpeninsula Regional Open Space District
95. Mid-Peninsula Water District
96. Midway City Sanitary District
97. Modesto Irrigation District
98. Mokelumne Hill Cemetery District
99. Mokelumne Hill Veterans Memorial District
100. Montara Water and Sanitary District
101. Monte Rio Recreation and Park District
102. Monte Vista Water District
103. Monterey County Mosquito Abatement District
104. Monterey County Regional Fire Protection District
105. Monterey Peninsula Water Management District
106. Mount Shasta Recreation and Parks District
107. Mt View Sanitary District
108. Napa County Regional Park and Open Space District
109. Napa County Resource Conservation District
110. North Highlands Recreation and Park District
111. North Kern Cemetery District
112. North Santa Clara Resource Conservation District
113. North Sonoma Coast Fire Protection District
114. Northeast Willows Community Service District
115. Oak Hill Cemetery
116. Olympic Valley Public Service
117. Orange County Cemetery District
118. Orland Cemetery District
119. Oro Loma Sanitary District
120. Otay Water District
121. Oxnard Harbor District
122. Palm Springs Cemetery District
123. Parlier Cemetery District
124. Phelan Piñon Hills Community Services District

125. Pioneer Fire Protection District
126. Pleasant Hill Recreation and Park District
127. Pleasant Valley Recreation and Park District
128. Pomerado Cemetery District
129. Potter Valley Cemetery District
130. Potter Valley Irrigation District
131. Quartz Hill Water District
132. Quincy Fire Protection District
133. Rainbow Municipal Water District
134. Rancho Adobe Fire Protection District
135. Reclamation District No. 1000
136. Resource Conservation District of Greater San Diego County
137. Resource Conservation District of Santa Cruz County
138. Rim of the World Recreation and Park District
139. Rio Linda Elverta Recreation and Park District
140. Rosamond Community Services District
141. Rossmoor Community Services District
142. Rowland Water District
143. Running Springs Water District
144. Russian River Cemetery District
145. Sacramento Area Sewer District
146. San Bernardino Valley Municipal Water District
147. San Bernardino Valley Water Conservation District
148. San Jacinto Valley Cemetery District
149. San Lorenzo Valley Water District
150. San Mateo County Mosquito and Vector Control District
151. San Miguel Community Services District
152. Santa Fe Irrigation District
153. Serrano Water District
154. Shafter Recreation & Park District
155. Shasta Valley Cemetery District
156. Sierraville Public Utility District
157. Soledad Community Health Care District
158. Sonoma Resource Conservation District
159. Sonoma Valley Fire District
160. South Kern Cemetery District
161. South San Joaquin Irrigation District
162. South Santa Clara Valley Memorial District
163. Southern Inyo Fire Protection District
164. Southern Marin Fire Protection District
165. Southgate Recreation & Park District
166. Stege Sanitary District
167. Sunnyslope County Water District

168. Sunrise Recreation and Park District
169. Sutter-Yuba Mosquito and Vector Control District
170. Tehachapi Valley Recreation and Park District
171. Templeton Community Services District
172. Thunderbird County Water District
173. Tiburon Fire Protection District
174. Tulare Mosquito Abatement District
175. Tuolumne Utilities District
176. Turlock Mosquito Abatement District
177. Twain Harte Community Services District
178. Twentynine Palms Public Cemetery District
179. Union Public Utility District
180. Union Sanitary District
181. Valley Center Fire Protection District
182. Valley Sanitary District
183. Valley-Wide Recreation and Park District
184. Ventura River Water District
185. Visalia Memorial District
186. Volcano Community Services District
187. Wasco Recreation and Parks District
188. Weaverville/Douglas City Parks & Recreation District
189. West County Wastewater District
190. West Side Cemetery District
191. Western Municipal Water District
192. Westlands Water District
193. Williams Cemetery District
194. Winton Cemetery District
195. Wrightwood Community Services District
196. Wynola Water District
197. Yolo County Flood Control and Water Conservation District

Counties, Cities, JPAs, and Schools

198. Fallbrook Union Elementary School District
199. Sacramento County
200. Sewerage Commission – Oroville Region
201. Sweetwater Authority
202. Tehama County Transportation Commission
203. Vallecitos School District

Local Business and Nonprofit Organizations

- 204. Alvarado Veterinary Hospital
- 205. Fallbrook Food Pantry
- 206. Friends of Fallbrook Library
- 207. Michelle's Place Cancer Resource Center
- 208. Writing by Design



California Special Districts Association
Districts Stronger Together

[CONTACT US](#) [JOIN](#) [SUPPORT](#)



[LOGIN](#)

Blog Viewer

US House Passes Historic Legislation Defining Special Districts in Federal Law



By Vanessa Gonzales posted 7 days ago

0 LIKE

By @Kyle Packham

Federal Legislation Would Open Funding Opportunities for Special Districts Providing Essential Services to Nearly All of California's 39 Million Residents

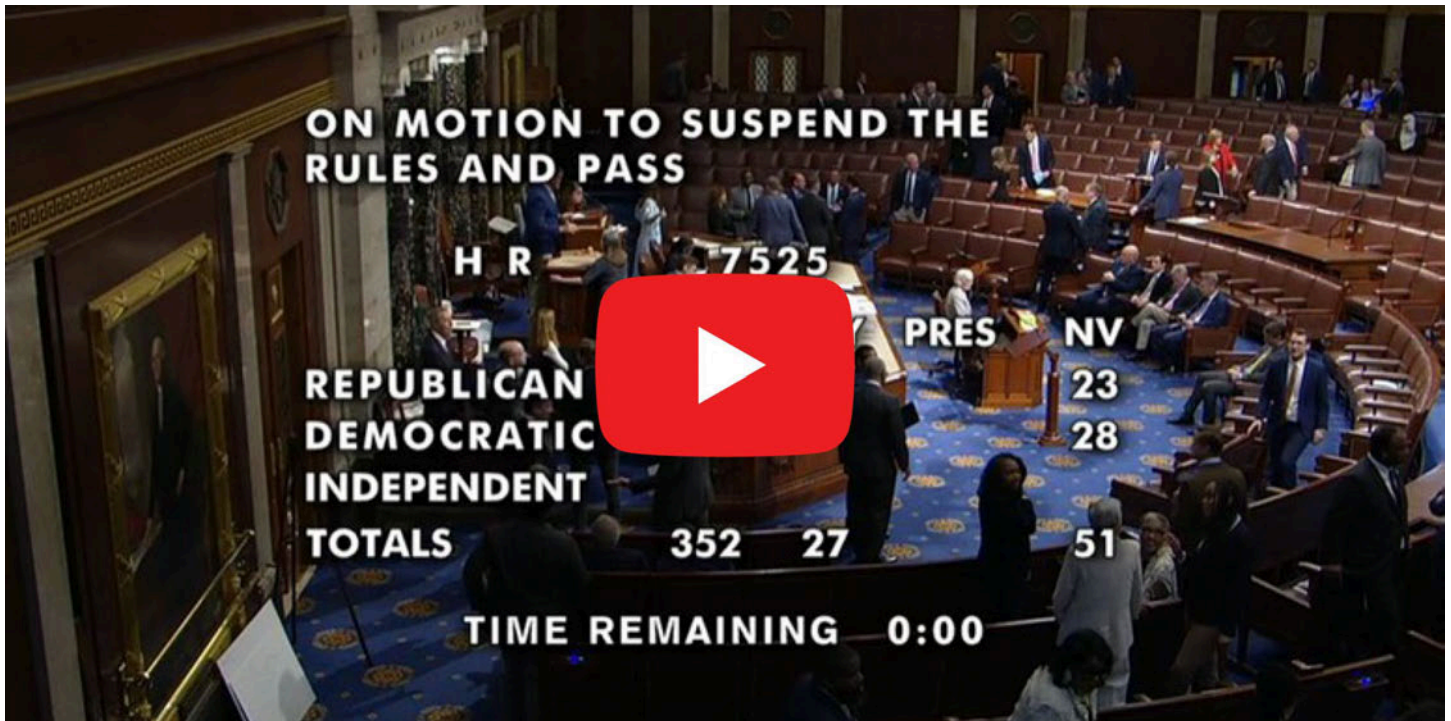

Yesterday, in a major victory for special districts and the National Special Districts Coalition (NSDC), the U.S. House of Representatives overwhelmingly passed the *Special District Grant Accessibility Act (H.R. 7525)*, legislation that would codify a first-ever definition of “special district” in federal law. Additionally, the bill would direct the White House Office of Management and Budget to require federal agencies to ensure that special districts are eligible for all appropriate forms of federal assistance.

[Contact us](#)



The bipartisan legislation, which cleared the House on an overwhelming 352-27 vote, is authored by Representatives Pat Fallon (R-TX) and Brittany Pettersen (D-CO) and was cosponsored by 14 Members of the California Congressional Delegation from both sides of the aisle. Action now turns to the Senate, where NSDC is working with key Members in an effort to advance a companion measure.

Over 250 special districts and other organizations sent letters or signed CSDA's [April 9 Coalition letter](#) to California's Congressional Delegation in support of H.R. 7525. Special districts and other organizations not listed on the April 9 letter are encouraged to [sign-on using this online form](#) to be added to an updated letter CSDA will soon send to California's United States Senators.

The Special District Grant Accessibility Act is the top priority of NSDC, of which CSDA is a founding member. Last week, CSDA Chief Executive Officer Neil McCormick and Chief Advocacy and External Affairs Officer Kyle Packham traveled to Washington D.C. together with special district representatives from eight other states. The contingent met with the White House Office of Intergovernmental Affairs and over 20 legislative offices including the offices of California's Senator Alex Padilla and Senator Laphonza Butler.



While in Washington, CSDA was honored to join the coalition in meeting with the sponsor and original cosponsor of the Special District Grant Accessibility Act. Representatives Fallon and Pettersen both spoke on the House Floor in support of H.R. 7525:

- [Congressman Pat Fallon \(R-TX\) Floor Speech](#)
- [Congresswoman Brittany Pettersen \(D-CO\) Floor Speech](#)

Following passage of the legislation, the sponsor and original co-sponsor released the following quotes respectively in a nationwide press release:

“The consequence of current law is some communities served by special districts cannot access certain federal funding opportunities, which has a huge impact on the ability of special districts to provide vital services and meet community needs,” Congressman Fallon said. “H.R. 7525 re-sets the board and ensures special districts have the resources, autonomy, and flexibility to address the unique challenges and opportunities facing their communities.”

“There are 3,500 special districts in Colorado alone, which are responsible for critical services for our communities ranging from drinking water and wastewater management, to health care, transit, and natural resource conservation,” said Congresswoman Pettersen. “Unfortunately, special districts have not had a specific definition under federal law, meaning Coloradans in these areas are missing out on federal funding opportunities that help other communities with reliable ambulance service, wildfire protections and firefighters, pandemic response services, and more. I’m proud to work on this bipartisan bill with Congressman Fallon to help us better adapt to the complexity of local governments and ensure Coloradans and people across the country have access to the support they need.”

H.R. 7525 would require the White House Office of Management and Budget to issue guidance to federal agencies requiring special districts to be recognized as local governments for the purpose of federal financial assistance determinations. Specifically, H.R. 7525 would establish the following definition in Federal law (Title 13 of US Code):

“The term ‘special district’ means a political subdivision of a State, with specified boundaries and significant budgetary autonomy or control, created by or pursuant to the laws of the State, for the purpose of performing limited and specific governmental or proprietary functions that distinguish it as a significantly separate entity from the administrative governance structure of any other form of local government unit within a State.”

“Since the formation of California’s first special district in 1887, the now 2,000 independent special districts in our state have confronted some of our nation’s biggest challenges at the local level, be they drought, flood, fire, and more,” said Neil McCormick, Chief Executive Officer of the California Special Districts Association and Immediate Past Chair of NSDC. “Passage of H.R. 7525, the Special District Grant Accessibility Act, by the United States House of Representatives is a historic moment in recognizing the value of special districts to the communities they serve and improving intergovernmental partnership as we confront the many challenges ahead.”

“We’re extremely grateful to Representatives Fallon and Pettersen for their strong leadership on behalf of special districts and for marshaling this historic bill through the House,” said Ann Terry, Chair of the National Special Districts Coalition (NSDC). “We hope today’s overwhelming vote in the House sets the stage for timely action in the Senate and will carry H.R. 7525 through to the President’s desk, where it will be signed into law.”

According to NSDC, there are more than 35,000 special districts in the U.S. providing a range of infrastructure and essential community programs across the country including parks, water, sanitation, fire protection, ports, cemeteries, healthcare, electricity, pest control, and libraries.

For more information on H.R. 7525, visit [Special District Grant Accessibility Act - California Special Districts Association \(csda.net\)](https://www.csda.net/special-district-grant-accessibility-act).

- #AdvocacyNews
- #FeatureNews
- #Governance
- #Revenue

0 comments **15 views**

Permalink

<https://www.csda.net/blogs/vanessa-gonzales/2024/05/07/us-house-passes-historic-legislation-defining-spec>



1112 "I" Street,
Suite 200
Sacramento, CA
95814
[877.924.2732](tel:877.924.2732) |
[916.442.7887](tel:916.442.7887)

FIND IT FAST

- SDLF Scholarships
- Register for an Event
- Career Center
- Membership
- Information
- Take Action
- Bill Tracking
- Knowledge Base
- Privacy Policy

CALIFORNIA SPECIAL DISTRICTS ALLIANCE



SPECIAL DISTRICT LEADERSHIP FOUNDATION



DISTRICTS MAKE THE DIFFERENCE